

# **2216 Nways Multiaccess Connector ESCON Channel Adapter Planning and Setup Guide**

Document Number GA27-4193-00



2216 Nways Multiaccess Connector  
ESCON Channel Adapter



# Planning and Setup Guide





2216 Nways Multiaccess Connector  
ESCON Channel Adapter



# Planning and Setup Guide

**Note**

Before using this information and the product it supports, be sure to read the general information under Appendix E, "Notices" on page E-1 and Appendix F, "Safety Information" on page F-1.

**First Edition (June 1997)**

This edition applies to the IBM 2216 1-port ESCON Channel Adapter (FC 2287).

Order publications through your IBM representative or the IBM branch office serving your locality. Publications are not stocked at the address given below.

A form for readers' comments appears at the back of this publication. If the form has been removed, address your comments to:

Department CJBA  
Design & Information Development  
IBM Corporation  
PO Box 12195  
RESEARCH TRIANGLE PARK NC 27709-9990  
USA

When you send information to IBM, you grant IBM a non-exclusive right to use or distribute the information in any way it believes appropriate without incurring any obligation to you.

© **Copyright International Business Machines Corporation 1997. All rights reserved.**

Note to U.S. Government Users — Documentation related to restricted rights — Use, duplication or disclosure is subject to restrictions set forth in GSA ADP Schedule Contract with IBM Corp.

---

# Contents

|                                                              |      |
|--------------------------------------------------------------|------|
| Trademarks                                                   | viii |
| <b>About This Manual</b>                                     | ix   |
| How This Book Is Organized                                   | ix   |
| 2216 Library Overview                                        | xi   |
| Visit our Web Sites                                          | xii  |
| Information, Updates, and Corrections                        | xiii |
| Related Publications                                         | xiv  |
| <b>Chapter 1. Planning for the ESCON Channel Adapter</b>     | 1-1  |
| ESCON Channel Adapter Functions                              | 1-1  |
| The 2216 LAN/WAN Gateway                                     | 1-2  |
| Multi-Path Channel+ (MPC+) Support                           | 1-3  |
| 2216 ESCON Functional Support                                | 1-4  |
| Introduction to Host Planning for the 2216                   | 1-6  |
| Determining Your System Requirements                         | 1-8  |
| Channel Support                                              | 1-8  |
| Number of Hosts, Host Programs, and Users                    | 1-11 |
| Limits for 2216 ESCON Network Interfaces and Subchannels     | 1-13 |
| 2216 Availability and Backup                                 | 1-16 |
| 2216 Planning Considerations                                 | 1-22 |
| Activities to Plan for Before Installation and Configuration | 1-22 |
| Considerations for Including the 2216 in a Network           | 1-23 |
| Optimizing Performance                                       | 1-24 |
| Host Definition Planning                                     | 1-26 |
| IOCP Definition for the 2216                                 | 1-26 |
| Defining the 2216 to the Operating System                    | 1-30 |
| Defining the 2216 to Host Programs                           | 1-31 |
| Planning for 2216 Support                                    | 1-39 |
| 2216 ESCON Channel Adapter Problem Analysis and Resolution   | 1-40 |
| Reconfiguration                                              | 1-40 |
| <b>Chapter 2. Installing the ESCON Channel Adapter</b>       | 2-1  |
| Unpack and Verify                                            | 2-1  |
| Select an Appropriate Adapter Slot                           | 2-2  |
| Power Off the IBM 2216                                       | 2-2  |
| Orient the Adapter                                           | 2-3  |
| Insert the Adapter                                           | 2-4  |
| Seat the Adapter                                             | 2-5  |
| Connect the Adapter Cable                                    | 2-6  |
| Position the Adapter Cable                                   | 2-7  |
| <b>Chapter 3. Testing the ESCON Channel Adapter</b>          | 3-1  |
| Power On the IBM 2216                                        | 3-1  |
| Run Diagnostics on the New ESCON Adapter                     | 3-2  |
| Run the Light Test on the New Fiber Optic Cable              | 3-6  |
| <b>Chapter 4. Configuring the ESCON Channel Adapter</b>      | 4-1  |
| ESCON Channel Adapter Overview                               | 4-1  |
| LAN Channel Station (LCS) Support                            | 4-4  |

|                                                                            |            |
|----------------------------------------------------------------------------|------------|
| Link Services Architecture (LSA) Support                                   | 4-5        |
| Multi-Path Channel+ (MPC+) Support                                         | 4-11       |
| Configuring the ESCON Interface                                            | 4-13       |
| Accessing the ESCON Interface                                              | 4-13       |
| ESCON Configuration Commands                                               | 4-14       |
| ? (Help)                                                                   | 4-14       |
| Add                                                                        | 4-14       |
| Delete                                                                     | 4-26       |
| Mod                                                                        | 4-27       |
| List                                                                       | 4-28       |
| Exit                                                                       | 4-29       |
| <b>Chapter 5. Monitoring the ESCON Channel Adapter</b>                     | <b>5-1</b> |
| Accessing the ESCON Console Process                                        | 5-1        |
| ESCON Interface Console Commands                                           | 5-2        |
| ? (Help)                                                                   | 5-2        |
| List                                                                       | 5-2        |
| Net                                                                        | 5-4        |
| Exit                                                                       | 5-5        |
| ESCON LCS Interface Console Commands                                       | 5-5        |
| ? (Help)                                                                   | 5-5        |
| List                                                                       | 5-5        |
| Exit                                                                       | 5-6        |
| ESCON LSA Interface Console Commands                                       | 5-7        |
| ? (Help)                                                                   | 5-7        |
| List                                                                       | 5-7        |
| Exit                                                                       | 5-9        |
| ESCON MPC+ Interface Console Commands                                      | 5-10       |
| ? (Help)                                                                   | 5-10       |
| List                                                                       | 5-10       |
| Exit                                                                       | 5-14       |
| <b>Chapter 6. Network Management for the ESCON Channel Adapter</b>         | <b>6-1</b> |
| IBM 2216 ESCON Supported MIBs                                              | 6-2        |
| <b>Appendix A. Diagnostic Testing of the ESCON Channel Adapter</b>         | <b>A-1</b> |
| Diagnosing Operational Code and Configuration Problems                     | A-1        |
| Diagnosing Hardware Problems                                               | A-1        |
| Invoking the IBM 2216 Diagnostic Function                                  | A-1        |
| Using the ESCON Adapter Diagnostic Functions                               | A-3        |
| Interactive Test Options                                                   | A-6        |
| Optical Power Measurement Test                                             | A-7        |
| <b>Appendix B. Factory Plugging Defaults for the ESCON Channel Adapter</b> | <b>B-1</b> |
| Assumptions                                                                | B-1        |
| Plugging Sequences                                                         | B-1        |
| <b>Appendix C. LED Indicators for the ESCON Channel Adapter</b>            | <b>C-1</b> |
| ESCON Adapter LEDs                                                         | C-1        |
| <b>Appendix D. ELS Messages</b>                                            | <b>D-1</b> |
| ESCON Network Interface (ESC) Messages                                     | D-1        |
| LCS Virtual Network Interface (LCS) Messages                               | D-12       |
| LSA Virtual Network Interface (LSA) Messages                               | D-16       |



|                                                                                |      |
|--------------------------------------------------------------------------------|------|
| MPC+ Virtual Network Interface (MPC) Messages . . . . .                        | D-28 |
| Logical Link Control (LLC) Messages . . . . .                                  | D-34 |
| <b>Appendix E. Notices</b> . . . . .                                           | E-1  |
| Electronic Emission Notices . . . . .                                          | E-1  |
| European Community (EC) Mark of Conformity Statement . . . . .                 | E-2  |
| Japanese Voluntary Control Council for Interference (VCCI) Statement . . . . . | E-2  |
| Korean Communications Statement . . . . .                                      | E-3  |
| <b>Appendix F. Safety Information</b> . . . . .                                | F-1  |
| <b>List of Abbreviations</b> . . . . .                                         | X-1  |
| <b>Glossary</b> . . . . .                                                      | X-3  |
| <b>Index</b> . . . . .                                                         | X-13 |



---

## Figures

|       |                                                                          |      |
|-------|--------------------------------------------------------------------------|------|
| 1-1.  | Representative Network Containing the 2216                               | 1-2  |
| 1-2.  | IBM 2216 with ESCON Channel Adapter in a Network                         | 1-7  |
| 1-3.  | Single System ESCON Connection Example                                   | 1-9  |
| 1-4.  | Multiple System ESCON Connections Example                                | 1-10 |
| 1-5.  | 2216 EMIF Attachment Example                                             | 1-11 |
| 1-6.  | Rules for LAN/WAN Gateway Definitions for LCS and LSA Subchannels        | 1-14 |
| 1-7.  | Rules for Definitions for MPC+                                           | 1-15 |
| 1-8.  | 2216 and Host Backup Using Two LAN Segments                              | 1-17 |
| 1-9.  | 2216 and Host Backup Using One LAN Segment                               | 1-18 |
| 1-10. | 2216 and Host Backup - Multi-Path Channel+                               | 1-21 |
| 1-11. | ESCON Channel Configuration Example                                      | 1-27 |
| 1-12. | EMIF Host Configuration Example                                          | 1-28 |
| 4-1.  | 2216 Connected to a Host through an ESCON Channel Adapter - Logical View | 4-1  |
| 4-2.  | 2216 ESCON Virtual Net Handlers for LCS and LSA                          | 4-3  |
| 4-3.  | 2216 ESCON Virtual Net Handlers for MPC+                                 | 4-3  |
| 4-4.  | Configuring LAN Channel Station (LCS) Virtual Net Handlers               | 4-4  |
| 4-5.  | Configuring Link Services Architecture (LSA) Virtual Net Handlers        | 4-5  |
| 4-6.  | Configuring Virtual Net Handlers for LSA Direct Connection               | 4-6  |
| 4-7.  | Configuring Virtual Net Handlers for LSA APPN Connection                 | 4-7  |
| 4-8.  | Configuring Virtual Net Handlers for LSA DLSw Connection                 | 4-9  |
| 4-9.  | Configuring Virtual Net Handlers for LSA DLSw Local Conversion           | 4-10 |
| 4-10. | Configuring Virtual Net Handlers for Multi-Path Channel+ (MPC+)          | 4-11 |

---

## Tables

|      |                                                                          |      |
|------|--------------------------------------------------------------------------|------|
| 0-1. | Hardcopy Publications that Are Shipped with the 2216                     | xi   |
| 0-2. | Softcopy Publications that Are Shipped on the CD-ROM                     | xii  |
| 1-1. | ESCON Functional Support for 2216                                        | 1-5  |
| 1-2. | 2216 ESCON Functional Summary                                            | 1-6  |
| 1-3. | Number of Concurrent Connections                                         | 1-12 |
| 1-4. | LAN Adapter Maximum Frame Sizes and Channel Adapter Maximum Block Sizes  | 1-25 |
| 4-1. | ESCON Interface Configuration Commands                                   | 4-14 |
| 5-1. | ESCON Interface Console Commands                                         | 5-2  |
| 5-2. | ESCON LCS Interface Console Commands                                     | 5-5  |
| 5-3. | ESCON LSA Interface Console Commands                                     | 5-7  |
| 5-4. | ESCON MPC+ Interface Console Commands                                    | 5-10 |
| 6-1. | ESCON Supported MIB Groups                                               | 6-2  |
| B-1. | Slot Numbering for IBM 2216 - All Slots                                  | B-1  |
| B-2. | Installation Preferences for FC 2280s (LIC 280s) and FC 2281s (LIC 281s) | B-1  |
| B-3. | Installation Preferences for Other Adapters                              | B-1  |

---

## Trademarks

The following terms are trademarks of the IBM Corporation in the United States or other countries or both:

|            |                                          |
|------------|------------------------------------------|
| APPN       | Advanced Peer-to-Peer Networking         |
| ESCON      | ES/3090                                  |
| ES/9000    | Hardware Configuration Definition        |
| IBM        | MVS/ESA                                  |
| MVS/XA     | NetView                                  |
| Nways      | OS/2                                     |
| PR/SM      | Processor Resource/Systems Manager       |
| System/360 | System/370                               |
| System/390 | VM/ESA                                   |
| VM/XA      | VSE/ESA                                  |
| VTAM       | Virtual Telecommunications Access Method |

Microsoft, Windows, and the Windows 95 logo are trademarks or registered trademarks of Microsoft Corporation.

UNIX is a registered trademark in the United States and other countries licensed exclusively through X/Open Company Limited.

The following terms, denoted by a double asterisk (\*\*), used in this publication, are trademarks of other companies:

|                          |                                       |
|--------------------------|---------------------------------------|
| NCS                      | Apollo Computer, Inc.                 |
| Network Computing System | Apollo Computer, Inc.                 |
| Network File System      | Sun Microsystems, Inc.                |
| NFS                      | Sun Microsystems, Inc.                |
| OSF                      | Open Software Foundation, Inc.        |
| OSF/Motif                | Open Software Foundation, Inc.        |
| X Window System          | Massachusetts Institute of Technology |

Other company, product, and service names, which may be denoted by a double asterisk (\*\*), may be trademarks or service marks of others.

---

## About This Manual

This manual describes how to plan for, install, configure, and use the ESCON Channel Adapter for the IBM 2216.

This manual is written for network planners or administrators, teleprocessing specialists, system programmers, and persons responsible for the physical installation, setup and maintenance of the IBM 2216 with an ESCON Channel Adapter.

---

## How This Book Is Organized

This manual contains the following chapters and appendixes:

- Chapter 1, "Planning for the ESCON Channel Adapter" on page 1-1 describes how to plan for the installation of ESCON Channel Adapters in a 2216.
- Chapter 2, "Installing the ESCON Channel Adapter" describes the physical installation of an ESCON Channel Adapter in a 2216.
- Chapter 3, "Testing the ESCON Channel Adapter" describes how to test the 2216 ESCON Channel Adapter.
- Chapter 4, "Configuring the ESCON Channel Adapter" describes how to configure the 2216 using the command line interface. You may also configure the ESCON Channel Adapter using the Graphical User Interface Configuration (GUI Config) program.
- Chapter 5, "Monitoring the ESCON Channel Adapter" describes how to monitor the 2216 using the command line interface.
- Chapter 6, "Network Management for the ESCON Channel Adapter" describes system management support and Management Information Bases (MIBs) provided for the 2216 ESCON Channel Adapter.
- Appendix A, "Diagnostic Testing of the ESCON Channel Adapter" describes diagnostic procedures for the 2216 ESCON Channel Adapter.
- Appendix B, "Factory Plugging Defaults for the ESCON Channel Adapter" describes factory installed adapter positions of the 2216 ESCON Channel Adapter.
- Appendix C, "LED Indicators for the ESCON Channel Adapter" describes the meanings of the LED indicators for the IBM 2216 ESCON Channel Adapter.
- Appendix D, "ELS Messages" describes new and changed ELS messages.

A list of abbreviations, glossary, and index are also included at the back of this manual.

Planning and Installation

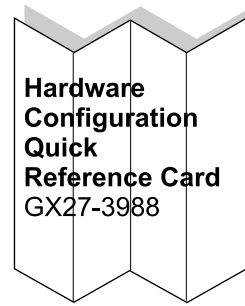
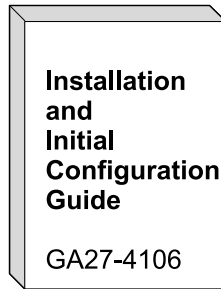

Configuration

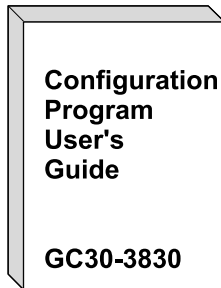

Diagnostics/Maintenance

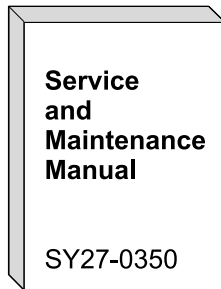

Operations and Network Administration

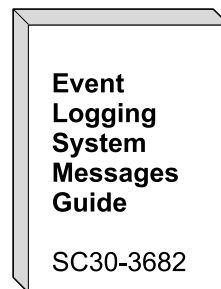
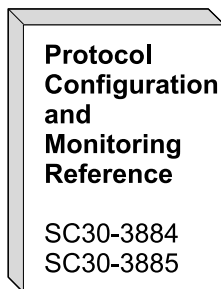
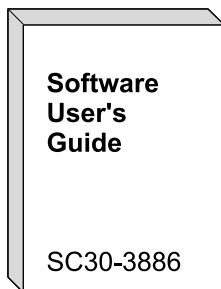

---

## 2216 Library Overview

The following list shows the publications in the IBM 2216 library, arranged according to tasks.

---

*Table 0-1. Hardcopy Publications that Are Shipped with the 2216*

---

These documents are shipped in hardcopy and are also contained on the 2216 CD-ROM, SK2T-0405.

### Planning

GA27-4105 *2216 Nways Multiaccess Connector Introduction and Planning Guide*

This book explains how to prepare for installation and perform an initial configuration.

### Installation

GA27-4106 *2216 Nways Multiaccess Connector Installation and Initial Configuration Guide*

This booklet explains how to install the IBM 2216 and verify its installation.

GX27-3988 *2216 Nways Multiaccess Connector Hardware Configuration Quick Reference*

This reference card is used for entering and saving hardware configuration information used to determine the correct state of an IBM 2216.

### Diagnostics and Maintenance

SY27-0350 *2216 Nways Multiaccess Connector Service and Maintenance Manual*

This book provides instructions for diagnosing problems with and repairing the IBM 2216.

### Safety

SD21-0030 *Caution: Safety Information—Read This First*

This book provides translations of caution and danger notices applicable to the installation and maintenance of a IBM 2216.

---

## **Operations and Network Management**

The following list shows the books that support the Nways Multiprotocol Access Services program.

SC30-3886 *Nways Multiprotocol Access Services Software User's Guide*

This book explains how to:

- Configure, monitor, and use the Nways Multiprotocol Access Services software.
- Use the Nways Multiprotocol Access Services command-line router user interface to configure and monitor the network interfaces and link-layer protocols shipped with the IBM 2216.

SC30-3884 *Nways Multiprotocol Access Services Protocol Configuration and Monitoring Reference, Volume 1*

SC30-3885 *Nways Multiprotocol Access Services Protocol Configuration and Monitoring Reference, Volume 2*

These books describe how to access and use the Nways Multiprotocol Access Services command-line user interface to configure and monitor the routing protocol software shipped with the product.

They include information about each of the protocols that the devices support.

SC30-3682 *Nways Event Logging System Messages Guide*

This book contains a listing of the error codes that can occur, along with descriptions and recommended actions to correct the errors.

## **Configuration**

GC30-3830 *Configuration Program User's Guide*

This book discusses how to use the Nways Multiprotocol Access Services Configuration Program.

---

---

## **Visit our Web Sites**

This IBM web page provides product information:

<http://www.networking.ibm.com/216/216prod.html>



## Information, Updates, and Corrections

This page provides information on engineering changes, clarifications, and fixes that were implemented after the books were printed:

<http://www.networking.ibm.com/216/216lib.html#relnts>

---

## Related Publications

Other publications that might be useful to you include:

- *IBM ES/9000, IBM ES/3090 Input/Output Configuration Program User's Guide and ESCON Channel to Channel Reference Volume A04*, GC38-0097†
- *Maintenance Information for Enterprise Systems Connection Links*, SY27-2597†
- *IBM I/O Configuration Program User's Guide and Reference* (308x processors), GC28-1027†
- *Fiber Optic Link Planning*, GA23-0367

Materials available for Virtual Telecommunications Access Method (VTAM) Version 4.4

- *VTAM V4R4 Network Implementation Guide*, SC31-8370
- *VTAM V4R4 Resource Definition Reference*, SC31-8377

Materials available for the IBM Transmission Control Protocol/Internet Protocol for VM (TCP/IP for VM) program and for Multiple Virtual Storage (TCP/IP for MVS) program

- *IBM TCP/IP V2R4 for VM: Planning and Customization*, SC31-6082†
- *IBM TCP/IP V2R2 for VM: Installation and Interoperability*, GG24-3624†
- *IBM TCP/IP V4R2.1 for MVS: Planning and Customization*, SC31-6085†
- *IBM TCP/IP V4R2.1 for MVS: Quick Reference Guide*, SX75-0082†.

---

† You can get this publication from your IBM representative or your local IBM branch office. Ask your IBM representative for information on purchasing other manuals or kits.

---

## Chapter 1. Planning for the ESCON Channel Adapter

This chapter describes how to plan for the installation of the 2216 ESCON Channel Adapter. It includes the following topics:

- “ESCON Channel Adapter Functions”
- “Introduction to Host Planning for the 2216” on page 1-6
- “Determining Your System Requirements” on page 1-8
- “2216 Planning Considerations” on page 1-22
- “Host Definition Planning” on page 1-26
- “Planning for 2216 Support” on page 1-39

---

### ESCON Channel Adapter Functions

The ESCON Channel Adapter (FC 2287) provides the IBM 2216 with access to SNA and TCP/IP host applications from LANs, WANs, and ATM over a duplex-to-duplex multimode fiber-optic cable. The adapter features:

- High-performance IP and SNA host-application access, featuring Multi-Path Channel+ (MPC+) support for high-throughput APPN high-performance routing (HPR) to VTAM 4.4 SNA applications.
- APPN intermediate session routing (ISR) to VTAM 3.4 (or higher) SNA applications.
- APPN and IP routing over any other 2216 interface.
- Dependent LU Requestor (DLUR) in APPN to provide connectivity between dependent downstream SNA devices and VTAM SNA applications.
- Boundary access node (BAN) support in APPN to provide connectivity between downstream BAN Frame Relay Access Devices (FRADs) and VTAM SNA applications.
- IP route selection based on static, RIP, OSPF and BGP-4 routes and filtering of IP frames coming from or destined for the channel.
- Data link switching (DLSw) support for VTAM 3.4 (or higher) SNA applications.  
DLSw allows for local (single 2216) conversion from SDLC and LANs to the channel and remote (via DLSw partners) connectivity to SNA devices on SDLC, LANs, and ATM forum-compliant LAN emulation (LANE).
- ESCON channel-to-channel connectivity for Token Ring, Ethernet, and ATM LAN emulation.
- Support for up to four ESCON adapters.
- Support for up to 32 ESCON logical addresses (subchannels) per adapter for access to up to 32 hosts for LSA or 16 hosts for LCS or 16 hosts for MPC+ (assuming these types are not mixed on the adapter) when used with an IBM 9032 or 9033 ESCON Director or access to up to 15 logical host images in EMIF-capable processors operating in a logically partitioned (LPAR) mode.

## The 2216 LAN/WAN Gateway

An 2216 with an ESCON Channel Adapter that provides access for LAN-to-host applications is called a *2216 LAN/WAN gateway*.

The 2216 LAN gateway gives LAN devices concurrent access to VTAM and TCP/IP programs running on host computers.

Figure 1-1 represents a possible environment consisting of 2216s, hosts, and LAN devices (it is only a sample configuration).

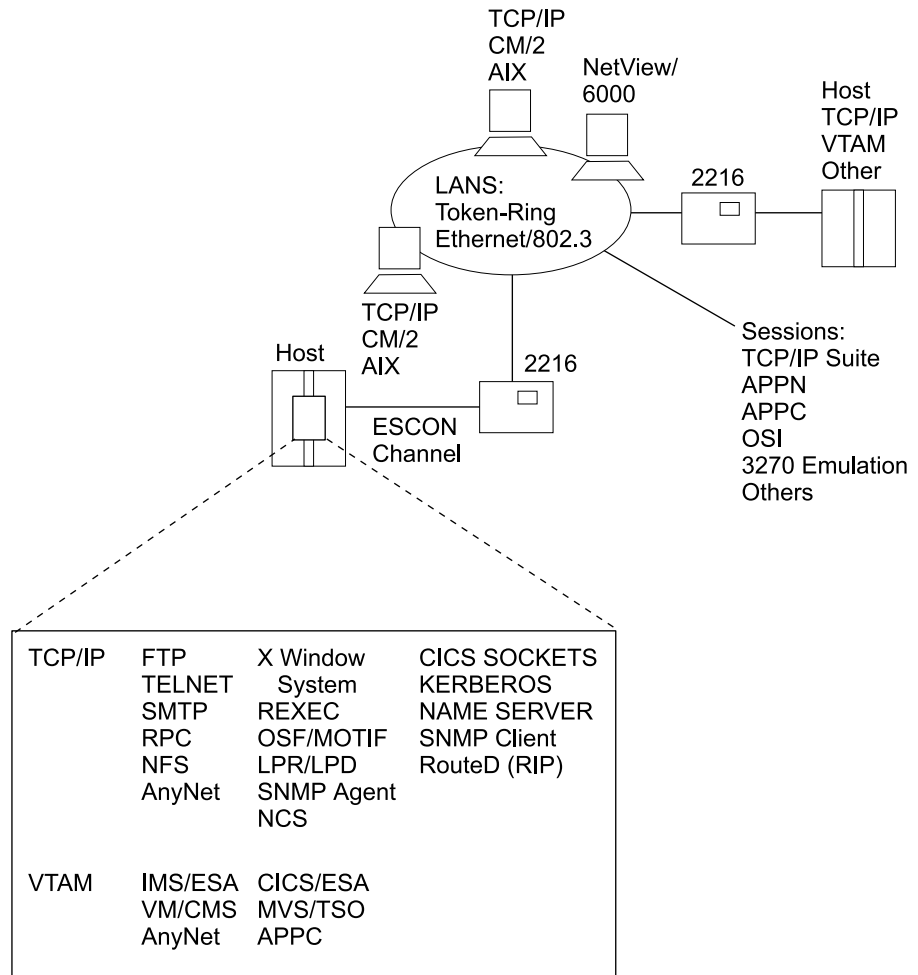

Figure 1-1. Representative Network Containing the 2216

The 2216 LAN/WAN gateway with ESCON Channel Adapter supports the following communications:

- Between a LAN/WAN device and a host, through a 2216 (LAN/WAN-to-host)
- From a device on one LAN/WAN to a device on a different LAN/WAN, with host routing support.

See Table 1-1 on page 1-5 for more information on LAN/WAN devices.

In both cases, LAN/WAN-to-channel connections in the 2216 are dedicated (defined as part of the host and 2216 configuration). Each host program (using either one subchannel or a pair of subchannels, depending on the host program type)

communicates through a LAN/WAN adapter in the 2216. LAN/WAN-to-channel connections (LAN/WAN gateway definitions) are defined during configuration for the 2216 by associating the subchannels used by the host programs to the LAN/WAN adapters.

The dedicated definition allows faster processing of frames, because the 2216 need not determine the route a frame must take. For each LAN/WAN-to-host definition, data typically follows the same path through the 2216 when going both to the host and going to the LAN/WAN.

The host and LAN/WAN device can each be one of the following:

- A TCP/IP client, server, or IP router.

**Note:** This support is provided by Logical Channel Station (LCS) virtual network handlers in the 2216.

- A PU 5 (VTAM), PU 2.0, PU 2.1, APPN End Node (EN), or Network Node (NN)

**Note:** This support is provided by Link Services Architecture (LSA) virtual network handlers in the 2216.

The LAN/WAN device can also be a PU 4 with the IBM Network Control Program (NCP) on the IBM 3745 or 3746.

### Multi-Path Channel+ (MPC+) Support

The 2216 provides one level of MPC support, *High Performance Data Transfer (HPDT)*, also referred to as *MPC+*. HPDT MPC connections provide more efficient transfer of data than non-HPDT MPC connections.

The 2216 Multi-Path Channel support, which is called Multi-Path Channel+ (MPC+), provides more efficient transfer of data by using high-performance data transfer (HPDT) services (in VTAM) to provide data packing without data movement and chain scheduling of programs. While MPC+ in the 2216 does not fully make use of HPDT services (that is, it does data movement), it does support receiving data that fully uses the HPDT services in VTAM.

The level of MPC used for an MPC connection is automatically determined by negotiation between the partner nodes.

**When HPDT MPC Is Used** If both partner nodes support HPDT MPC, HPDT MPC is automatically used.

- The 2216 only supports HPDT MPC (also known as MPC+).
- You can control the level used in VTAM by coding the MPCLEVEL operand on the TRLE definition statement that defines the MPC connection. VTAM supports HPDT MPC if it is defined as an HPR APPN node that provides RTP-level HPR support.

**Note:** Keep in mind that pre-V4R4 VTAMs do not support HPDT MPC.

**When Non-HPDT MPC Is Used** If either partner node does not support HPDT MPC, non-HPDT MPC is automatically used.

The 2216 does not support non-HPDT MPC.

Multi-Path Channel+ (MPC+) connections allow you to code a single transmission group (TG) that uses multiple write-direction and read-direction subchannels.

## Adapter Functions

Because each subchannel operates in only one direction, the half-duplex turnaround time that occurs with other channel-to-channel connections is reduced. The 2216 MPC+ does not allow the subchannels of an MPC+ group to be on more than one physical channel.

If at least one read and one write path is allocated successfully, the MPC+ channel connection is activated. Additional paths (defined but not online) in an MPC+ group can later be dynamically added to the active group using the MVS VARY ONLINE command. For example, if there is a need for an increase in capacity to allow for extra traffic over a channel, additional paths can be added to the active group without disruption. Similarly, paths can be deleted from the active group when no longer needed using the MVS command VARY device OFFLINE.

Currently the 2216 MPC+ supports only APPN HPR.

**Note:** For the 2216 ESCON Channel Adapter, the terms *MPC+ Group* and *MPC+ Virtual Interface* mean the same thing.

## 2216 ESCON Functional Support

Depending on the environment, a 2216 with an ESCON Channel Adapter gives host applications access to different types of LANs/WANs. The particular networks supported depend on the communications protocols being used, which host applications they are used with, and which operating systems are supported.

2216 ESCON software provides support for TCP/IP and SNA Gateway host programs, and support for VTAM applications to Token-Ring, IEEE 802.3, Ethernet/V2, and LAN/WAN-attached devices.

Table 1-1 on page 1-5 illustrates the 2216 connections provided for each host program. The supported environments are grouped by protocol. The table shows the host programs, operating systems, and adapters that provide each protocol support. For example, the TCP/IP protocol is supported by the TCP/IP host program (for VM or MVS). For each of these host environments, the adapters that can be used are indicated with a Y in the table.

| <i>Table 1-1. ESCON Functional Support for 2216</i>                             |                                         |                         |             |                   |         |         |
|---------------------------------------------------------------------------------|-----------------------------------------|-------------------------|-------------|-------------------|---------|---------|
|                                                                                 | TCP/IP <sup>1</sup><br>(LCS)<br>Gateway | VTAM <sup>2</sup>       |             |                   |         |         |
|                                                                                 |                                         | SNA<br>(LSA)<br>Gateway | APPN<br>ISR | MPC+ <sup>3</sup> | DLSw    |         |
| <b>Token-Ring</b>                                                               | Y                                       | Y                       | Y           | Y                 | Y       |         |
| <b>Ethernet V2</b>                                                              | Y                                       | N                       | Y           | Y                 | Y       |         |
| <b>Ethernet 802.3</b>                                                           | Y                                       | Y                       | Y           | Y                 | Y       |         |
| <b>Serial PPP</b>                                                               | Y                                       | N                       | Y           | Y                 | Y       |         |
| <b>Serial FR:<br/>bridged<br/>routed</b>                                        | N                                       | N                       | Y           | Y                 | Y       |         |
|                                                                                 | Y                                       | N                       | Y           | Y                 | N       |         |
| <b>SDLC</b>                                                                     | N                                       | N                       | Y           | N                 | Y       |         |
| <b>X.25</b>                                                                     | Y                                       | N                       | Y           | N                 | Y       |         |
| <b>ATM LANE</b>                                                                 | Y                                       | Y                       | Y           | Y                 | Y       |         |
| <b>ATM Classical IP</b>                                                         | Y                                       | N                       | N           | N                 | N       |         |
| <b>Notes:</b>                                                                   |                                         |                         |             |                   |         |         |
| 1. TCP/IP 2.2 or higher.                                                        |                                         |                         |             |                   |         |         |
| 2. ESCON support requires an ESA operating system (V3R4 or higher).             |                                         |                         |             |                   |         |         |
| 3. MPC+ requires VTAM V4R4 and APPN HPR. VTAM V4R4 requires the following PTFs: |                                         |                         |             |                   |         |         |
| UW36478                                                                         | UW36159                                 | UW36490                 | UW36495     | UW36245           | UW36265 | UW36540 |
| UW36537                                                                         | UW36564                                 | UW36612                 | UW36614     | UW36861           | UW37958 | UW38105 |

### Channel and Network Connections

The following ESCON channel connections are supported:

- ES/3090J Processor (selected models)
- 9021 ES/9000 Processor
- 9121 ES/9000 Processor
- 9221 ES/9000 Processor
- 9032 and 9033 ESCON Directors
- 9036 ESCON Remote Channel Extender

---

### Introduction to Host Planning for the 2216

Table 1-2 summarizes the protocols, channels, networks, and management functions supported by the 2216 with an ESCON Channel Adapter.

*Table 1-2. 2216 ESCON Functional Summary*

| <b>Communications Protocols</b>                                                                                                     | <b>Channels and Networks</b>                                                                                                                                                                     | <b>Management</b>                                             |
|-------------------------------------------------------------------------------------------------------------------------------------|--------------------------------------------------------------------------------------------------------------------------------------------------------------------------------------------------|---------------------------------------------------------------|
| <ul style="list-style-type: none"><li>• TCP/IP</li><li>• Subarea SNA</li><li>• APPN ISR</li><li>• APPN HPR</li><li>• DLSw</li></ul> | <ul style="list-style-type: none"><li>• ESCON Channel</li><li>• Token-Ring Network</li><li>• Ethernet V2 Network</li><li>• IEEE 802.3 Network</li><li>• ATM LANE</li><li>• Frame Relay</li></ul> | <ul style="list-style-type: none"><li>• SNMP Client</li></ul> |

The 2216 offers a solution for customers with traditional hierarchical (host-centric) networks as well as those customers who are migrating to flat (network-centric) networks. Figure 1-2 on page 1-7 illustrates the latter, showing a local LAN and remote LAN gaining access to an existing hierarchical network (depicted by the cloud) through a 2216 with an ESCON Channel Adapter.



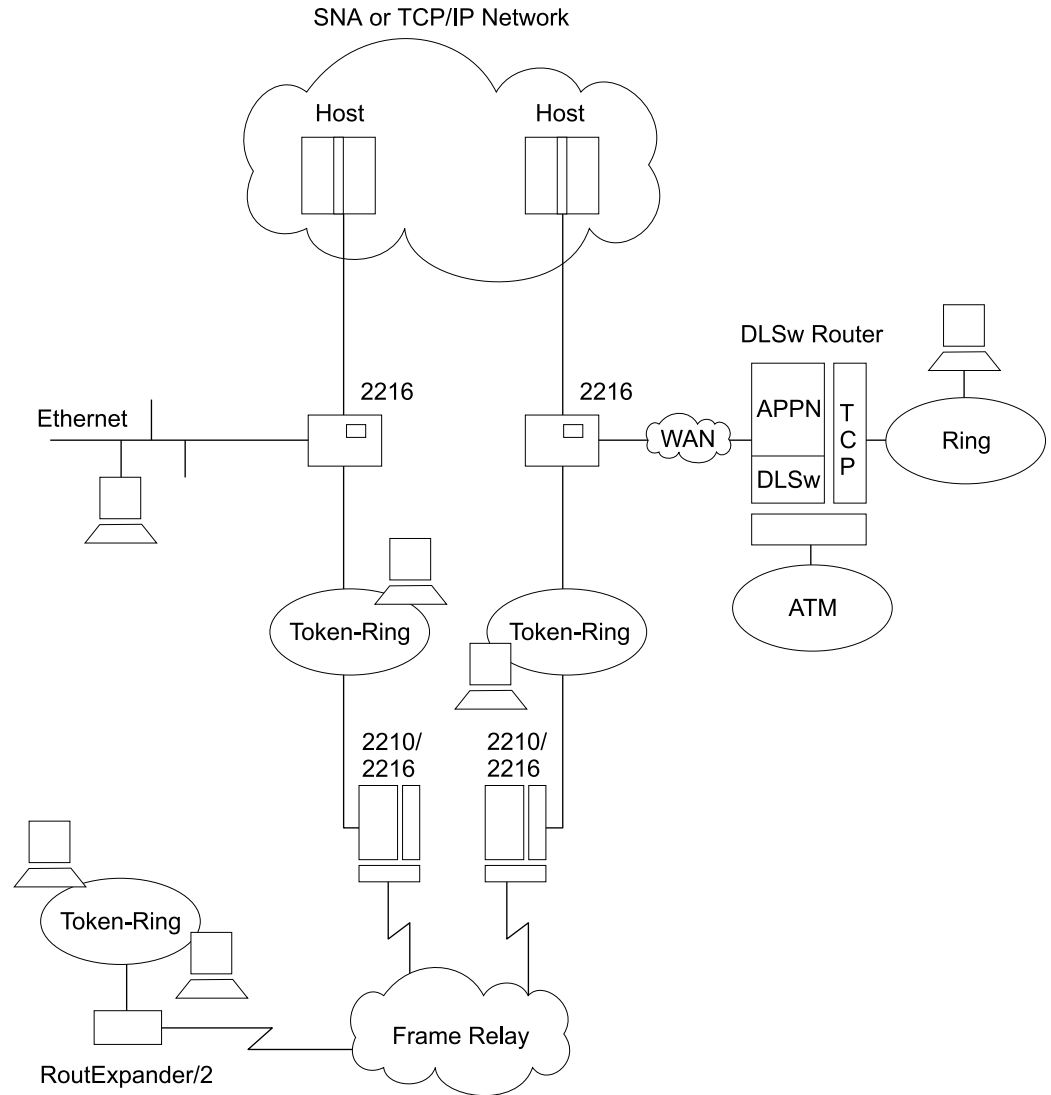

- All workstations can talk to all hosts.
- All workstations can talk to each other.

Figure 1-2. IBM 2216 with ESCON Channel Adapter in a Network

---

### Determining Your System Requirements

You will need a license for each 2216 that you install. To help you decide the number of 2216 licenses that you require, consider:

- What channel support is required?
- How many hosts, host programs, and users you need to support?
- How many physical channel and LAN connections you need to make?
- How many LAN/WAN gateway connections you need to define?
- How you can achieve high 2216 availability and hardware backup?
- How many logical host images will require connection to the 2216?

The following sections provide information designed to help you as you consider your requirements so you can determine how many 2216s you need.

### Channel Support

This section describes the characteristics of host channel support to help you understand how your host connection choices affect your 2216 needs.

#### ESCON Channel Characteristics and Configuration Examples

The 2216 with an ESCON adapter provides the following support:

- A maximum of four ESCON Channel Adapters per 2216.
- A maximum of 32 logical paths (ESCON subchannels) per 2216 ESCON Channel Adapter to the connected hosts. These logical paths can be defined to the same ESCON channel or divided among multiple ESCON channels.
- EMIF support for sharing ESCON channels for connection to multiple host images in LPAR-capable hosts. This support can be used with the IBM ESCON Directors connecting to multiple hosts, or for direct connection to a single host processor.
- A maximum of two IBM 9032 or 9033 ESCON Directors (ESCDs) in the path between the 2216 ESCON Channel Adapter and the host.
- Distances of up to 43 km (26.7 mi) using the ESCON Extended Distance Feature (XDF) available on host processors, ESCDs, and ESCON Remote Channel Extenders.

The following examples illustrate various 2216/ESCON configurations:

- Single and direct attachment between a S/370 or S/390 processor and 2216s  
See Figure 1-3 on page 1-9.
- Multiple systems attachment with ESCDs  
See Figure 1-4 on page 1-10.
- EMIF attachment between a S/370 or S/390 processor and 2216s.  
See Figure 1-5 on page 1-11.

**Direct Attachment Between a S/390 Host and a 2216:** In Figure 1-3, connection A shows a 2216 directly attached to a S/390 host channel. The separation of the host and the 2216 can be up to 3 km (1.86 mi).

**Single Attachment Between a S/390 Processor and 2216s:** Connections A, B, C, and D show 2216s attached to a single host.

The maximum distance between the S/390 host and the 2216 can vary from 3 km (1.86 mi) to 43 km (26.7 mi). For connection A, a maximum distance of 3 km (1.86 mi) can be achieved without ESCDs between the host and 2216. For connection B, a maximum distance of 9 km can be achieved with two ESCDs connected with multimode fiber. As shown in connections C and D, distances of up to 43 km can be achieved by using 9032 or 9033 ESCDs with the XDF or a combination of ESCDs and 9036 Remote Channel Extenders. The host must also have the XDF.

When two ESCON Directors are serially attached, the connection through one of the directors must be dedicated.

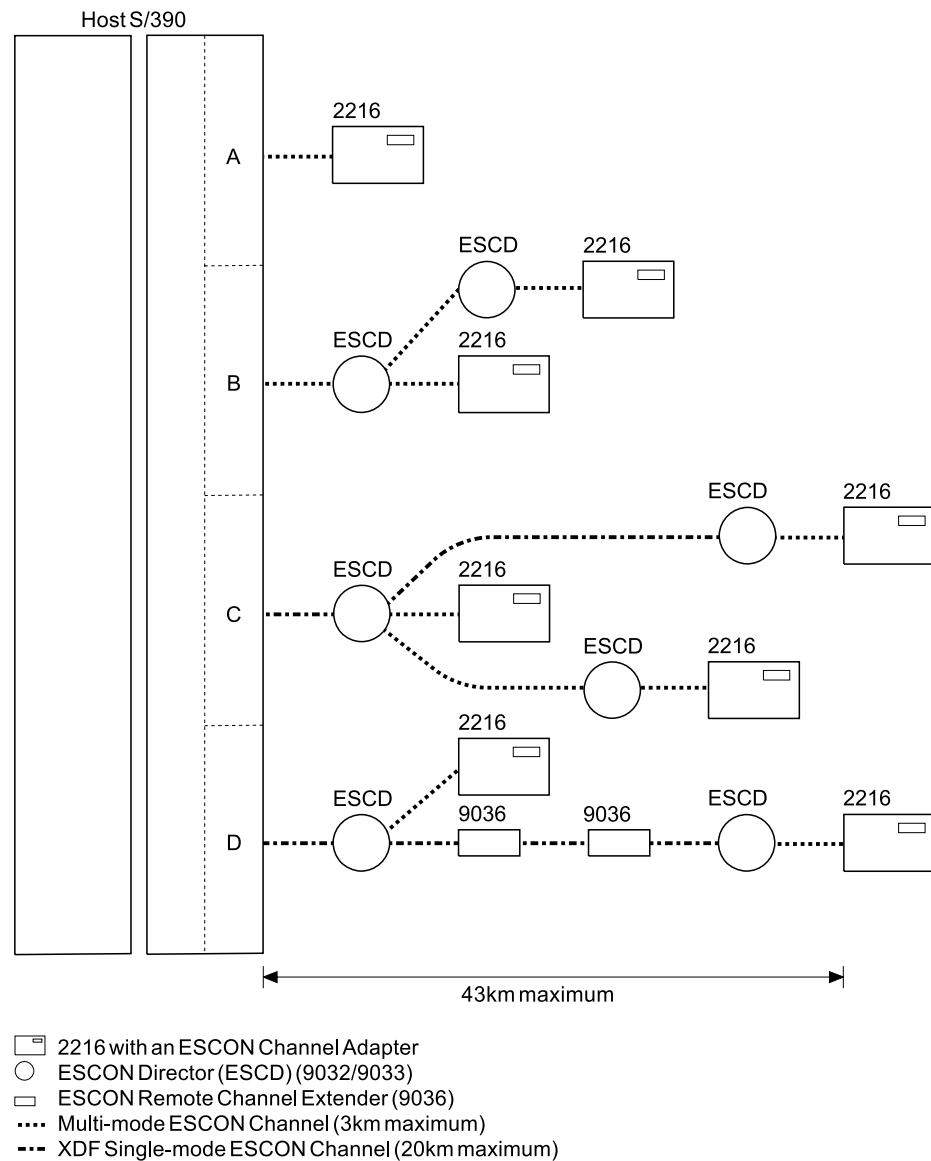

Figure 1-3. Single System ESCON Connection Example

## System Requirements

**Multiple Systems Attachment with ESCDs:** Figure 1-4 shows the connection of multiple S/390 hosts to single and multiple 2216s, with possible backup paths. A fault-tolerant solution can be designed using backup channels, multiple ESCDs, and/or multiple 2216s.

For additional information, see “2216 Availability and Backup” on page 1-16.

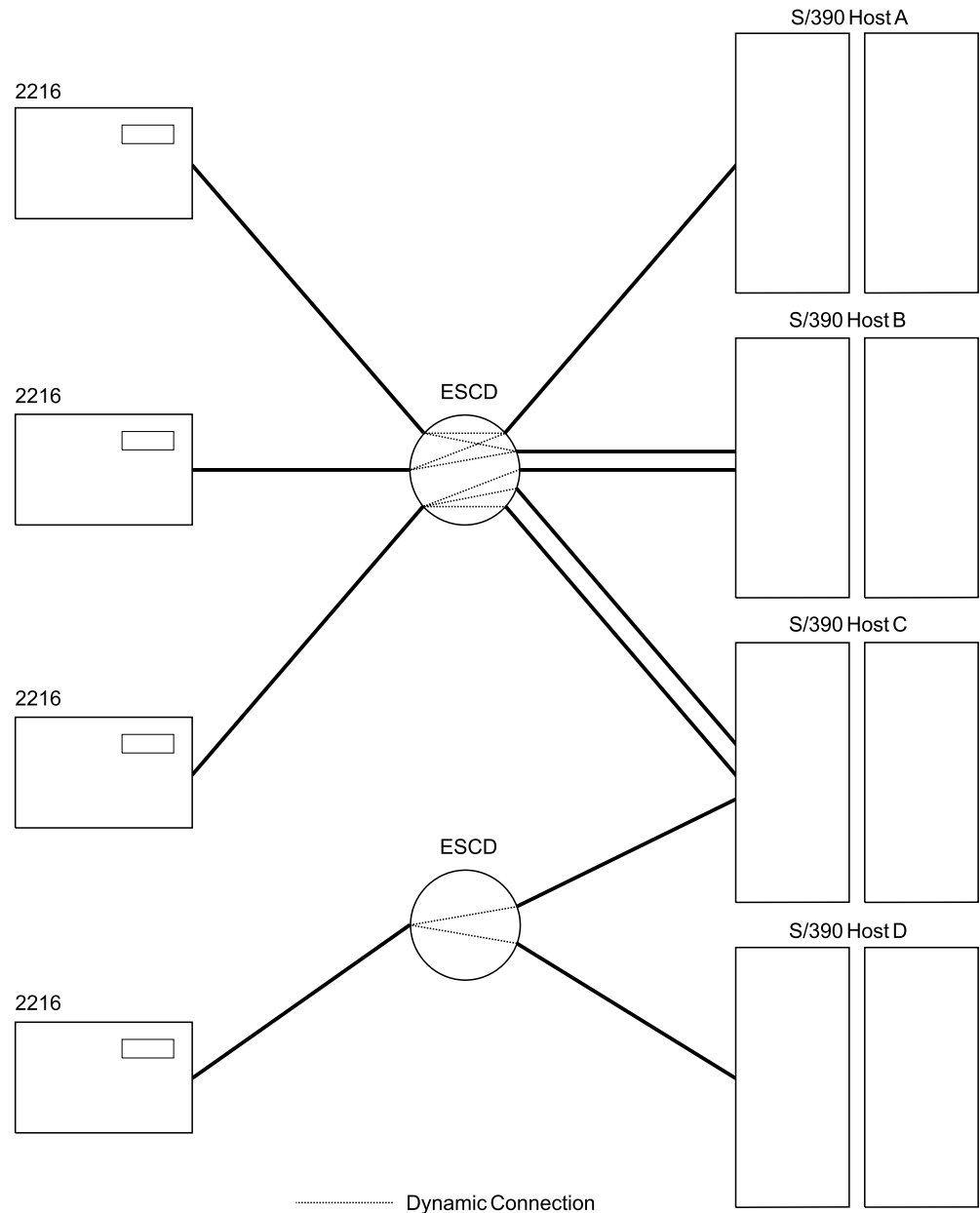

Figure 1-4. Multiple System ESCON Connections Example

**EMIF Attachment Between an ES/9000 Processor and a 2216:** The ESCON Multiple Image Facility (EMIF) allows the sharing of ESCON channels across Processor Resource/Systems Manager (PR/SM) logical partitions (LPARs). Prior to EMIF, dedicated channels to each logical partition were required.

EMIF is supported on all ES/9000 Model 511/711-based processors, and on the Model 520-based processors.

The 2216 ESCON Channel Adapter supports EMIF connectivity. This connection can be either direct host attachment or through an ESCD, and the logical hosts can be on the same or different physical hosts.

Figure 1-5 shows 2216 connectivity to an LPAR host. Logical hosts A and B are connected directly to the 2216. Logical hosts C, D and E are connected to multiple 2216s with a single ESCON connection from the ESCON Director. Each of these 2216s may be connected to both logical hosts B, C and D.

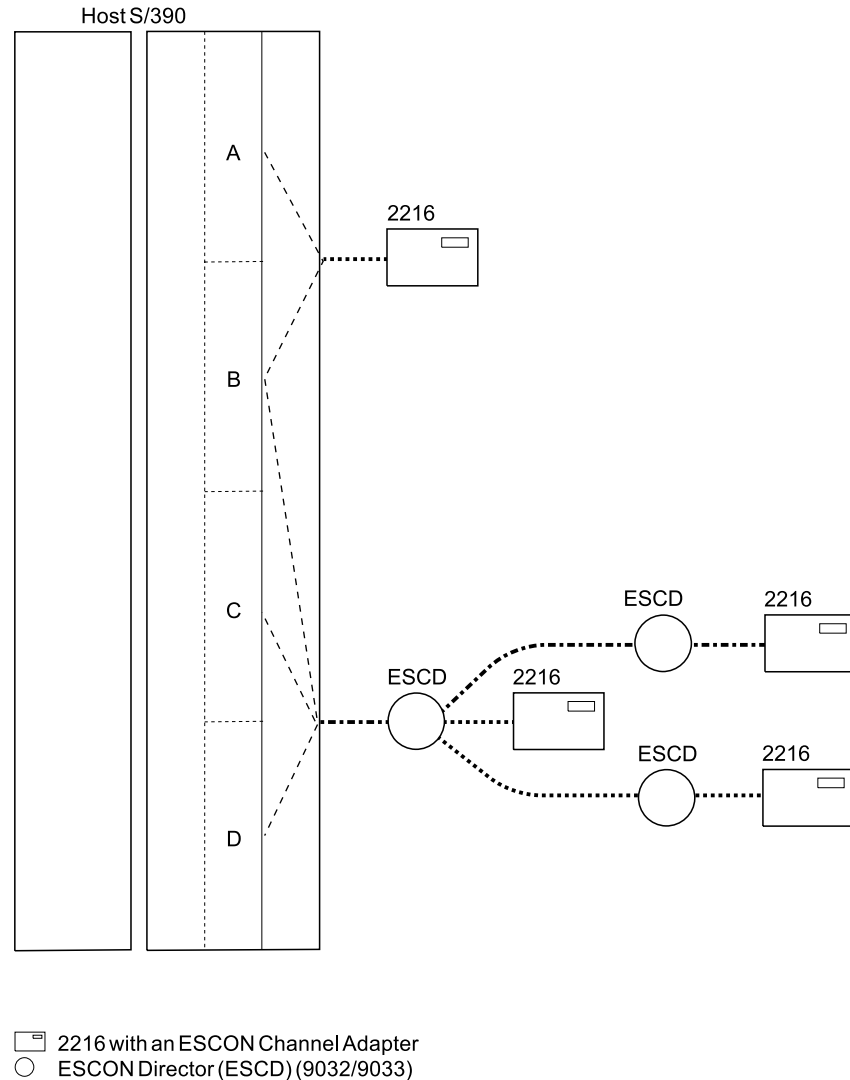

Figure 1-5. 2216 EMIF Attachment Example

## Number of Hosts, Host Programs, and Users

Your channel and LAN/WAN choices affect the number of hosts and host programs each 2216 can support. Also, your host program choice affects the number of users that can be supported by each 2216.

### Number of Hosts

The number of hosts (or the number of logical partitions in a single host) you can configure to use with one 2216 is influenced by several factors.

For ESCON hosts that are attaching to a 2216, the 2216 must have at least:

- One LSA subchannel for each host (or logical partition) running VTAM programs that are not using MPC+
- One LCS interface (two subchannels) for each host (or logical partition) connecting to TCP/IP
- Two subchannels for each host (or logical partition) that will be communicating with the 2216 using MPC+

Refer to “Limits for 2216 ESCON Network Interfaces and Subchannels” on page 1-13 for more information about the limits mentioned here.

### Number of Host Programs

The number of host programs that can run using a 2216 is less restrictive than the number of hosts that can use a 2216. This allows you to run more than one VTAM or TCP/IP host program on the same host (or in the same logical partition) using the same 2216.

For host programs that need to access a 2216, the 2216 must have at least:

- One subchannel (or subchannel pair) for each host program instance
- One LCS interface for each TCP/IP program.

Be aware that multiple VTAMs can share an LSA interface. If more than one VTAM needs to use the same LSA interface, each VTAM needs to open a different SAP.

Refer to “Limits for 2216 ESCON Network Interfaces and Subchannels” on page 1-13 for more information about the limits mentioned here.

### Number of Users

Table 1-3 describes the maximum number of users attached through a 2216 that can have concurrent sessions with host programs.

*Table 1-3. Number of Concurrent Connections*

| Host Program   | Maximum Number of Connections | See Note |
|----------------|-------------------------------|----------|
| VTAM           | 1500                          | 1        |
| TCP/IP for MVS | 10000                         | 2        |
| TCP/IP for VM  | 2000                          | 2, 3     |

1. Each LSA is limited to 2048 LLC link stations per SAP and each LAN adapter can have multiple SAPs. For SNA, this is the number of PUs supported. For APPN over MPC+, the number of users is based on APPN and not on the interface type.
2. For example, you can have up to 10 000 telnet sessions with TCP/IP for MVS using one 2216.
3. If you are using V2R4 of TCP/IP for VM, the maximum number of connections is limited to the amount of virtual storage. Therefore, it is possible to have more than 2000 connections.

## Limits for 2216 ESCON Network Interfaces and Subchannels

Subchannels will be associated with network interfaces when you configure the 2216 with an ESCON Channel Adapter as described in Chapter 4, “Configuring the ESCON Channel Adapter” on page 4-1.

A few simple rules govern the network interfaces:

1. Up to 16 interfaces can be configured.
2. Up to 32 subchannels can be used per ESCON Channel Adapter.
3. One LCS interface is required for each host (or logical partition) connecting to TCP/IP.
4. One or more subchannels are used for each VTAM host LAN/WAN gateway (LSA).
5. Two or more subchannels are required for each MPC+ interface.
6. EMIF provides attachment to multiple host images in LPAR-capable processors using a single host ESCON port. Attachment to multiple hosts including LPAR hosts is provided using an IBM 9032 or 9033 ESCON director.
7. VTAM (LSA) interfaces must be defined as either SNA gateway (TR, EN, ATM LANE) or loopback (APPN or DLSw). Gateway LSA interfaces are associated with a specific LAN or LANE interface. LSA loopback interfaces can be used for both APPN ISR and DLSw. An LSA interface cannot be both loopback and SNA gateway.
8. Each LCS interface must have a unique subnet address.
9. Each MPC+ interface (also known as an MPC+ group) must have at least two subchannels, one for reading and one for writing. If VTAM has the subchannel configured as “read” then the MPC+ group in the 2216 must have the subchannel configured as “write.”
10. MPC+ groups cannot share subchannels with other MPC+ groups.

## Sample Illustration of the Rules for LCS and LSA Subchannels

Figure 1-6 illustrates valid uses of subchannels by LAN adapters, according to these rules, for LCS and LSA.

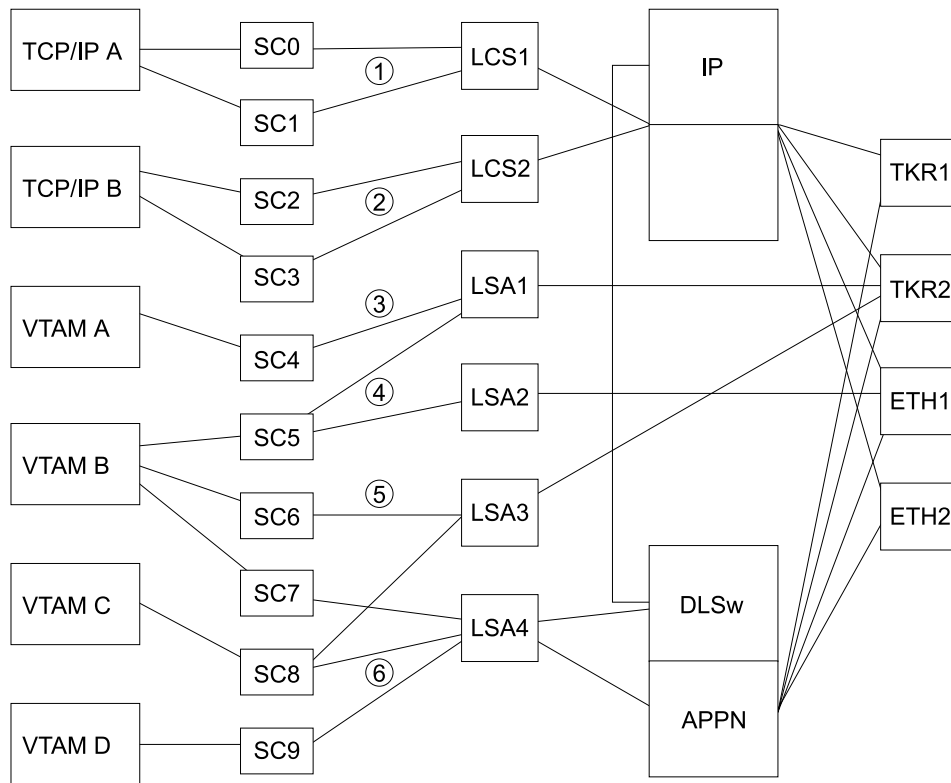

Figure 1-6. Rules for LAN/WAN Gateway Definitions for LCS and LSA Subchannels

- 1 LCS interface 1 uses subchannels 0 and 1 and provides access to all LAN interfaces for TCP/IP host A.
- 2 LCS interface 2 uses subchannels 2 and 3 and provides access to all LAN interfaces for TCP/IP host B.
- 3 LSA interface 1 uses subchannels 4 and 5 and provides access to TKR2 for VTAM hosts A and B, respectively.
- 4 LSA interface 2 uses subchannel 5 and provides access to ETH1 for VTAM host B.
- 5 LSA interface 3 uses subchannels 6 and 8 and provides access to TKR2 for VTAM hosts B and C.
- 6 LSA interface 4 uses subchannels 7, 8 and 9 and provides APPN ISR and DLSw access to all LAN interfaces for VTAM hosts B, C and D, respectively.



### Sample Illustration of the Rules for MPC+ Subchannels

Figure 1-7 illustrates valid uses of subchannels for MPC+.

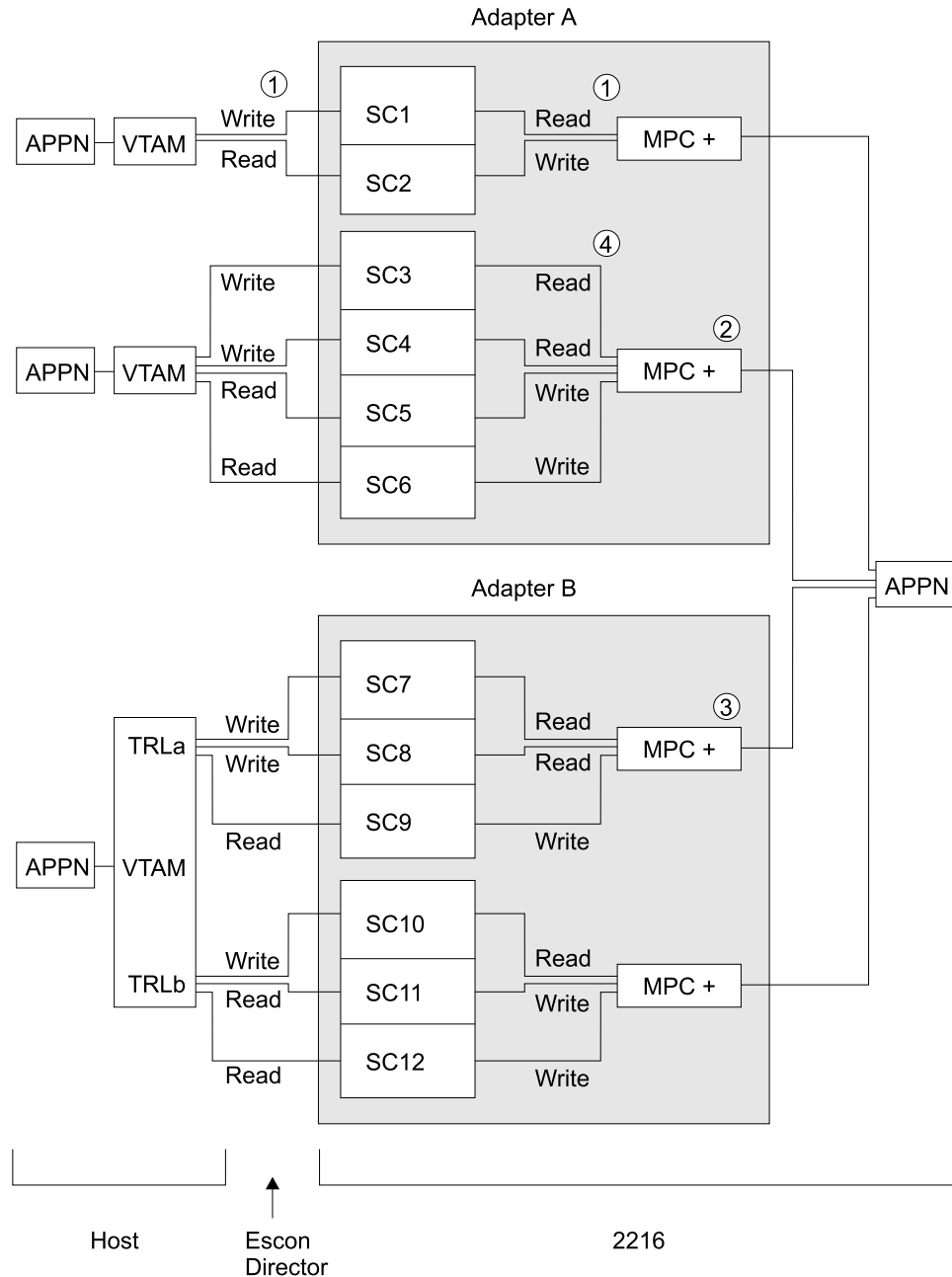

Figure 1-7. Rules for Definitions for MPC+

- 1 A subchannel which is configured as a “write” subchannel in VTAM is a “read” subchannel in the 2216 ESCON configuration.
- 2 There can be multiple MPC+ Groups on the same ESCON Channel Adapter.
- 3 Parallel MPC+ groups are supported but each must be placed in a separate TRL entry in the VTAM definition.

## System Requirements

- 4 Although you must have at least two subchannels (one read and one write) you can have more if there is at least one read subchannel and one write subchannel.

## 2216 Availability and Backup

In an environment where high availability is required, redundant 2216s can be used for backup.

### LCS and LSA Examples

To recover from host failures, a secondary host and a path to that host are required. In Figure 1-8, if Host A fails, users have access to Host B through 2216B. When Host A recovers, user access to Host A can be restored. This is just one example of recovering from a host failure. For host failures, other factors should also be considered, such as availability of applications and data on the secondary host.

To recover from 2216 failures, a second 2216 must be in the path to your hosts. In Figure 1-8, when 2216A fails, users of Host A could be rerouted through 2216B, because there are two paths to Host A. When 2216A recovers, users of Host A could be rerouted back through 2216A. There is only one path to Host B; and if 2216B fails, users will not be able to access Host B. This could be resolved by connecting and configuring Host B to 2216A. When 2216B recovers, user access to Host B could be restored. Again, other variations of this example could be employed to recover from 2216 failure.

The backup configuration in Figure 1-8 on page 1-17 is designed as follows:

- Host A has access to LAN Segment A through 2216A, and it has access to LAN Segment B through 2216B or 2216A.
- Host B has access to LAN Segment A and to LAN Segment B through 2216B.
- The node address for 2216A and 2216B is the same address. The node addresses can be different for TCP/IP, but not for SNA.
- The IP address for 2216A and 2216B is the same address.
- LAN Segment A and LAN Segment B are connected by a bridge or router.

For TCP/IP, a router cannot be used. Using a router would, by design, require the IP addresses for 2216A and 2216B to be different. The IP addresses for the 2216s must be the same so that the LAN devices can rediscover the route to the secondary 2216.

Figure 1-8 on page 1-17 and Figure 1-9 on page 1-18 show sample Token-Ring LAN segments, but the same principles apply to all the LAN types supported by the 2216.

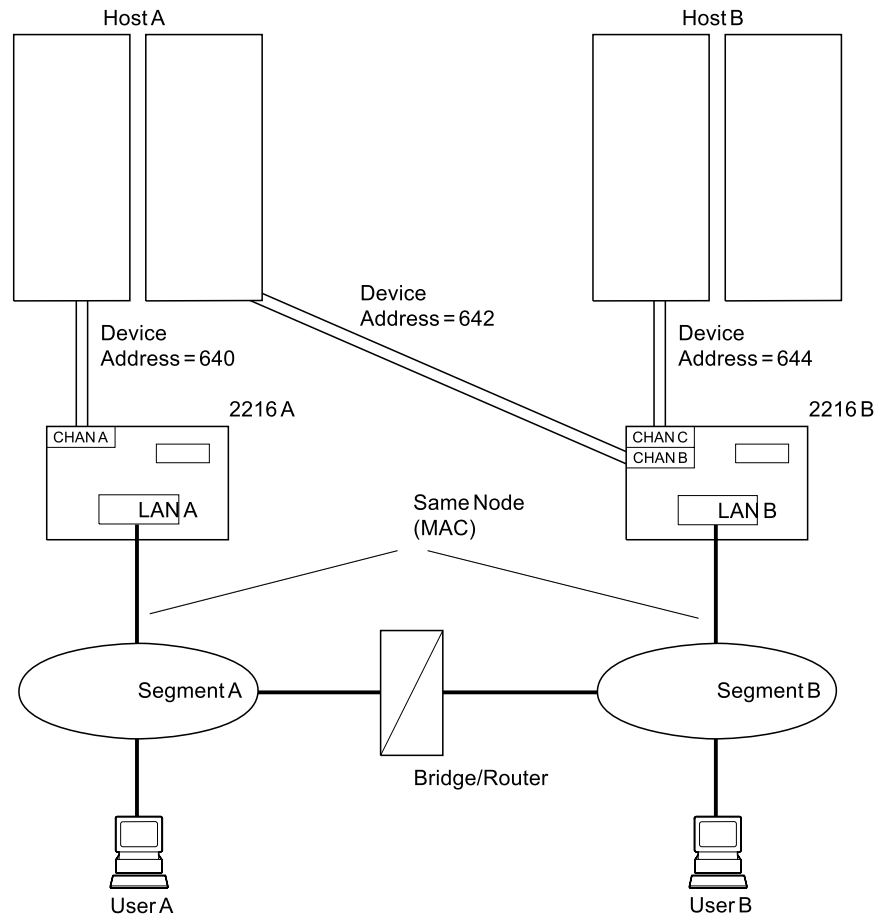

Figure 1-8. 2216 and Host Backup Using Two LAN Segments

Figure 1-9 provides the same host and 2216 backup as Figure 1-8 on page 1-17, except:

- 2216A and 2216B are connected to the same LAN segment.
- The primary 2216 must finish IPL before the secondary 2216 is restarted. Then the secondary LAN adapter will not become active on the LAN, because the node addresses are the same.

## System Requirements

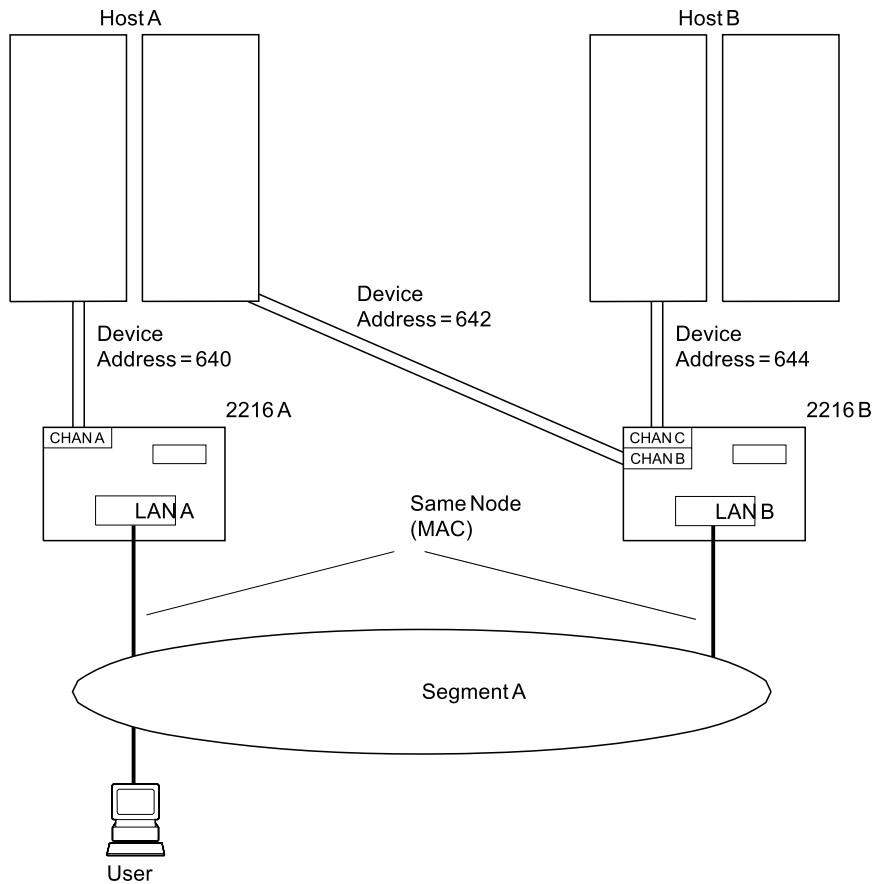

Figure 1-9. 2216 and Host Backup Using One LAN Segment

### Increasing Availability in VTAM Environments

To demonstrate backup in the VTAM environment using the system in Figure 1-8 on page 1-17, assume that both 2216s and hosts are operational and that 2216A and Host A are being used as the primary system. Only the XCA major node for 2216A is active. Refer to "VTAM Control Blocks Used to Configure LSA at the Host" on page 1-34 for more information.

#### When 2216A fails:

1. From Host A, deactivate the XCA major node for 2216A.
2. From Host A, activate the XCA major node for 2216B.
3. Host A users experience a temporary session loss, but connect through 2216B using the same node address.

#### When Host A fails:

1. 2216A detects the inactive host.
2. From Host B, activate the XCA major node for 2216B.
3. Host A users experience a temporary session loss, but connect to Host B through 2216B using the same node address.

In both cases, after the failure is corrected, sessions can be moved from 2216B to 2216A in a similar manner.

To demonstrate backup in the VTAM environment using the system in Figure 1-9 on page 1-18, assume that both hosts and both 2216s are operational, and that Host A and 2216A are being used as the primary system.

### When 2216A fails:

1. From 2216A, issue a 2216 command to remove 2216A from the LAN (stop the LAN-A adapter).
2. From 2216B, issue a 2216 command to attach 2216B to the LAN (start the LAN-B adapter).
3. From Host A, activate the XCA major node for 2216B.
4. Host A users experience a temporary session loss, but reconnect through 2216B using the same node address.

### When Host A fails:

1. From 2216A, issue a 2216 command to remove 2216B from the LAN (stop the LAN-A adapter).
2. From 2216B, issue a 2216 command to attach 2216B to the LAN (start the LAN-B adapter).
3. From Host B, activate the XCA major node for 2216B.
4. Host A users experience a temporary session loss, but connect to Host B through 2216B using the same node address.

In both cases, after the failure is corrected, sessions can be moved from 2216B to 2216A in a similar manner.

## Increasing Availability in a TCP/IP Environment

To demonstrate backup in a TCP/IP environment using the system in Figure 1-8 on page 1-17, assume that both 2216s and hosts are operational and that 2216A and Host A are being used as the primary system.

The TCP/IP Profile data set in the host includes the following statements:

**Note:** The default name for the TCP/IP profile data set is TCPIP.PROFILE.TCPIP for MVS and PROFILE TCPIP for VM.

- DEVICE statements for both 2216s attached to Host A (subchannels 640 and 642)
- LINK statements for the LAN adapters in both 2216s
- A HOME statement only for the LAN-A adapter
- A GATEWAY statement for your routing table that includes the LAN-A adapter
- A START statement for the device using the LAN-A adapter.

When 2216A fails, the OBEYFILE command can be executed from Host A to give users access to Host A through 2216B. You will need to issue a PING command to one device *after* the obey file has been used. You will need an obey file that contains:

- A STOP statement for the LAN-A adapter

The STOP statement deactivates ALL LAN adapters associated with that device. Therefore, if another LAN adapter was defined in 2216A for device

## System Requirements

640, a STOP for device 640 would stop both the LAN-A adapter and the other adapter. Depending on the type of 2216 failure, you may have to stop the LAN-A adapter using a 2216 command and execute the OBEYFILE command again.

- A HOME statement for the LAN-B adapter with the same IP address that is used for the LAN-A adapter
- A GATEWAY statement for your routing table that includes the LAN-B adapter
- A START statement for the device using the LAN-B adapter.

A similar obey file can be used to restore user access to Host A when it recovers.

These steps can also be followed using the system in Figure 1-9 on page 1-18.

TCP/IP host backup is not illustrated in Figure 1-8 on page 1-17 or Figure 1-9 on page 1-18. Because each TCP/IP host requires its own LAN adapter, you will not be able to recover from TCP/IP host failures as you can with VTAM hosts. You can, however, add a LAN adapter to either 2216 (or both if you want a backup for both hosts) and define a connection between the host and LAN adapters.

- These new adapters will not have the same node (or MAC) address as the adapters for your primary hosts (shown in Figure 1-8 on page 1-17 and Figure 1-9 on page 1-18).
- The adapters for the backup host will need to use the same IP addresses that you used for the primary hosts. You can switch the IP/LAN adapter association when one host fails in a similar manner as you do for 2216 failures described above.

For more information about TCP/IP configuration, refer to “Host Definition Planning” on page 1-26 and to “Related Publications” on page xiv.

### MPC+ Examples

Figure 1-10 shows an example of backup for Multi-Path Channel+ (MPC+).

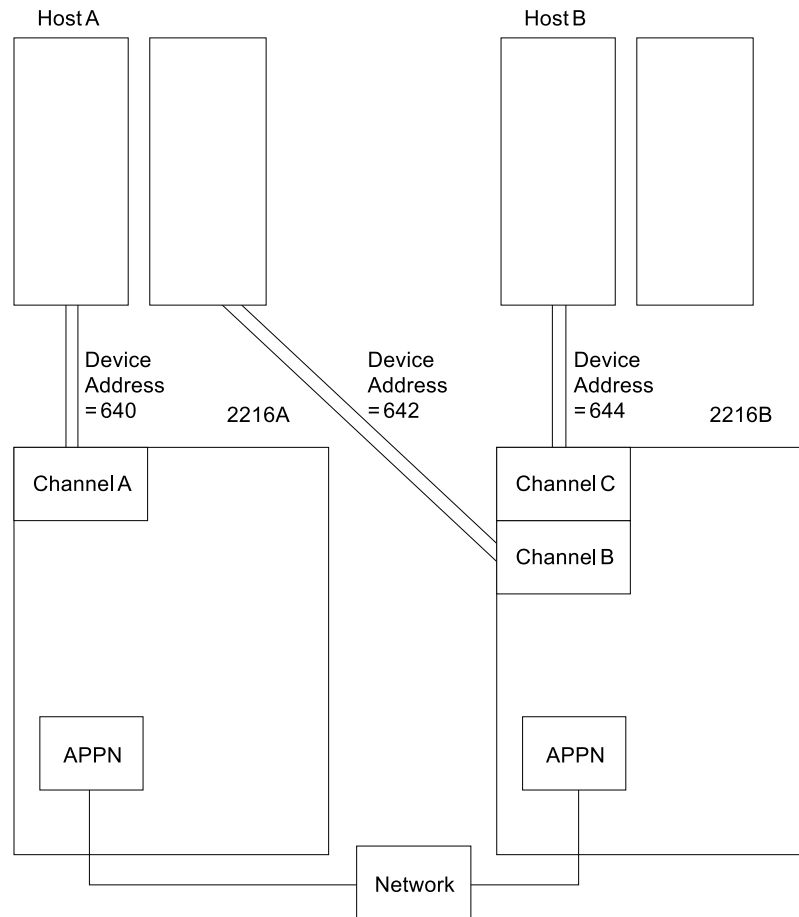

Figure 1-10. 2216 and Host Backup - Multi-Path Channel+

If one of the 2216s goes down, any HPR traffic should route around that down box. It is a property of APPN HPR to route around the down box. For example, if 2216A goes down the APPN HPR will path switch around the down box and the session that may have been going between HOST A and the network will now all go through 2216B.

To do the above you just need to make sure that 2216B has an APPN PORT/LINK set up to both Host A and Host B.

### 2216 Planning Considerations

This section discusses planning considerations for installing and configuring a 2216. It includes:

- What activities you need to plan for before installing and configuring the 2216 in your network
- What to consider about how the 2216 fits into your network
- What you will need to have available before you begin installation and configuration
- What to consider for supporting the 2216 in the network.

### Activities to Plan for Before Installation and Configuration

You will need to plan for the following activities prior to installing and configuring the 2216 in a network:

- Defining the 2216 for channel attachment
- Defining the 2216 for LAN attachment
- Supporting the 2216 in the network.

#### Defining the 2216 for Channel Attachment

Your system programmer will need to determine configuration and system generation (SYSGEN) parameter values for the following program types at the host:

- Control programs and operating systems (including IOCP, HCD for MVS, MVS, and VM)
- Host programs (including VTAM and TCP/IP)
- Applications
- Network management (including SNA management services and NetView).

The system generations and configurations should be done before the 2216 hardware is installed and released for customer use. “Host Definition Planning” on page 1-26, contains detailed information about host parameter definition for the 2216.

#### Defining the 2216 for LAN Attachment

Defining the 2216 for LAN attachment requires several tasks:

- LAN adapter address administration
- Changes to LAN device configurations to optimize performance
- Matching 2216 configuration parameters to those of your LAN or host devices.

#### Supporting the 2216 in the Network

“Planning for 2216 Support” on page 1-39 discusses considerations for:

- Determining 2216 problem reporting and resolution procedures
- Updating procedures, instructions, and network documentation
- Defining requirements for 2216 reconfiguration.



## Considerations for Including the 2216 in a Network

Host and LAN planners and administrators will need to be involved in integrating the 2216 into your network. System and application programmers will also participate in defining configuration parameters and installing code.

### Configuration Considerations

Before configuring the 2216 in your network, consider:

**Addresses** Group, functional, multicast, and node (universally or locally administered individual) addresses need to be assigned by the network administrator for each 2216 LAN adapter. These addresses may need to be specified in the configurations for LAN devices that will access a 2216.

**SAPs** For VTAM communication, the network administrator needs to decide the SAPs to be used for each 2216 LAN adapter.

Each VTAM host program that uses a 2216 LAN adapter is assigned a different SAP value. The SAP for each adapter can be used once on the adapter; VTAM can use the same SAP on different LAN adapters.

**Note:** If APPN and LSA are configured to use the same LAN adapter, they must use different SAPs.

The network administrator and system programmer must determine how to change the SAP value used by each LAN adapter, if necessary.

### MPC+ Timers

**Reply TO Timer** This is the amount of time that the MPC+ Group will wait to hear from across the channel during XID2 and DISC exchanges before it decides that the other end of the channel is not answering and this side should continue with the bring up or bring down of the MPC+ group.

**Sequencing Interval timer** Used to determine whether connection-oriented data is flowing smoothly across the connection on an MPC+ Group. The MPC+ control flows and the APPN activation/deactivation flows flow connection-oriented. Since these commands must have guaranteed delivery at the link level they flow connection-oriented and the Sequencing Interval timer is used to determine whether enough time has passed that checking of the delivery of connection-oriented traffic should be done.

**Note:** This value can be overwritten for each APPN PORT on an MPC+ Group. This is done during the APPN PORT configuration.

**LLC Timers** If a 2216 supports remote SNA connections (using a remote bridge, for example), consider what values are needed for LLC timers T1, Ti, and T2 on the LAN adapters.

**LAN Number** This number distinguishes between multiple network interfaces of the same type within one 2216. Link number for TCP/IP and ADAPNO for VTAM specify the LAN number to the host program.

## Planning Considerations

These definitions must be the same if both programs use the same network interface.

**Subchannels** The subchannels (logical paths for ESCON) must be defined for all 2216 LAN/WAN gateway definitions to associate 2216 channel adapters with 2216 LAN adapters.

### **PMF Password**

The Parameter Management Frames (PMF) password protects the station from an unauthorized setting of MIB attributes by a remote station using Simple Mail Transfer Protocol (SMTP) PMF frames.

### **LAN Data Transfer Rate**

The 2216 Token-Ring Adapter can be configured to transfer data at 4 Mbps or 16 Mbps. Select the data transfer rate to match your LAN.

**Receive Mode** Determines which frames will be received by the Ethernet adapter.

### **Transceiver Type**

Identifies the type of transceiver that the Ethernet adapter uses.

## Optimizing Performance

There are many parameters that affect the overall performance of a host-to-LAN network. The parameters that affect 2216 throughput are discussed in this section.

In planning the volume and flow of traffic over the network, consider the following configuration parameters. It is recommended that the default 2216 host parameters be used initially. You can then tune the network to optimize overall performance.

### **TCP/IP Window Size**

A larger TCP/IP window size allows more frames to be sent before requiring acknowledgement. This helps move frames through devices faster and requires less frequent processing of acknowledgements.

### **VTAM I/O Buffer Size**

Frames are segmented into more than one buffer when the frame size exceeds the VTAM I/O buffer size, causing additional processing overhead. Make the VTAM buffers large enough to contain the largest average frame size.

Also consider the following concepts:

### **Sharing Subchannels**

When defining a LAN/WAN gateway, dedicate a subchannel or subchannel pair for each network interface to ensure maximum performance.

### **Trace**

Using the 2216 trace function may affect performance noticeably.

### **Frame Size**

Most protocols segment data into packets based on restrictions of the network to which they are attached. Bridges, for example, may restrict the size of forwarded frames to the smaller of the two maximum sizes that can be handled by the LANs they connect. Frames that traverse different LAN types can be limited in size by the maximum frame size of the most restrictive LAN. Frames that are larger than the specified maximum size can get segmented into two or more packets for network transmission; the packets must be reassembled by the

receiver into their original size. Some programs and devices discard frames that are too large or too small.

Protocols and applications take these frame size limits into consideration when they determine their maximum frame size; some can negotiate to the largest common frame size that both sender and receiver can handle. (The 2216 does not negotiate frame size.) To reduce the effects of segmenting data into smaller frame sizes, you need to be aware of how devices on the network affect protocol packet size.

Table 1-4 shows the size of the largest frame that can be transferred by each type of 2216 LAN adapter.

*Table 1-4. LAN Adapter Maximum Frame Sizes and Channel Adapter Maximum Block Sizes*

| <b>Adapter Type</b>    | <b>Largest Frame Size</b> | <b>Maximum Block Size</b> |
|------------------------|---------------------------|---------------------------|
| Token-Ring (4 Mbps)    | 4.5 KB                    |                           |
| Token-Ring (16 Mbps)   | 17.5 KB                   |                           |
| Ethernet V2/IEEE 802.3 | 1.5 KB                    |                           |
| ESCON                  |                           | 32 KB                     |

---

### Host Definition Planning

This section provides information to help you plan for host definition. It includes information for system definition from the host perspective and information for definition from the 2216 perspective.

Before you can attach the 2216 to an ESCON channel, the host system must be configured correctly. The following series of steps is required to define the 2216 connection to the host. These definition steps should be done by your system programmer.

- 1** Define the 2216 to the host channel subsystem using either the host Input/Output Configuration Program (IOCP) or Hardware Configuration Definition (HCD) program.
- 2** Define the 2216 control unit to the host operating system.
- 3** Define the 2216 and configuration to the host program (TCP/IP or VTAM).

After the host definitions are complete, you must configure the 2216 ESCON interfaces using the command line interface, as described in Chapter 4, “Configuring the ESCON Channel Adapter” on page 4-1, or using the Nways MAS Configuration Program described in *Configuration Program User's Guide*, GC30-3830. Many of the parameters which you provide when you configure the 2216 must match corresponding parameters in the host definition.

Finally, the stations will need to be configured to communicate through the 2216 to the host applications.

The following sections describe host definition and provide sample host configuration statements.

### IOCP Definition for the 2216

The following sections describe examples of IOCP definitions for the 2216 with ESCON channel attachment. The output of the IOCP device definitions (I/O Configuration Data Set or IOCDS) can be generated using MVS, VM, VSE, or in a stand-alone environment. Refer to the *ES/9000 and ES/3090 Input/Output Configuration Program User's Guide Volume A04*, GC38-0097, for details.

#### Example IOCP Definition for the ESCON Channel

Figure 1-11 on page 1-27 shows an example of an ESCON configuration. The S/390 host is divided into two logical partitions (LP): LPA and LPB. A connection on path 30 is configured between LPA and 2216A through ESCD switch 00. LPA is attached to ESCD port C0 and 2216A is attached to port C1. The connection between port C0 and C1 is dynamic.

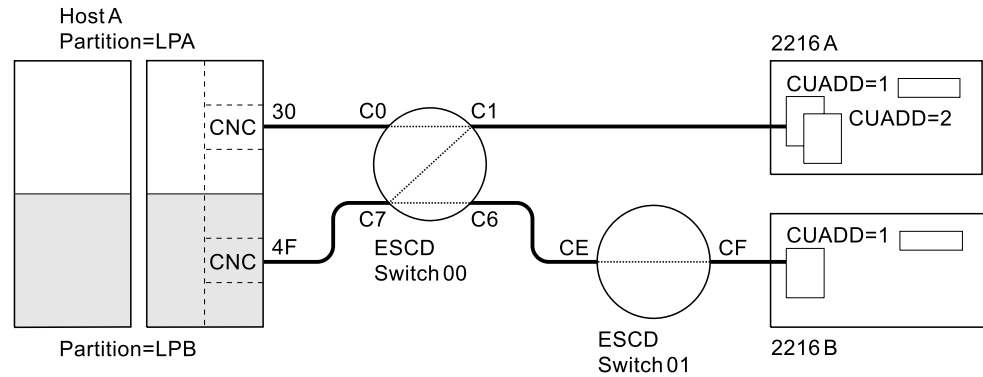

Figure 1-11. ESCON Channel Configuration Example

LPB on path 4F has a connection with 2216A through ESCD switch 00, and a connection with 2216B through ESCD switches 00 and 01. The connection between ports C7 and C6 is dynamic; the connection between ESCD ports CE and CF is dedicated.

The following example definitions match Figure 1-11:

Channel path definitions:

```
CHPID    PATH=((30)),TYPE=CNC,PART=(LPA),SWITCH=00
CHPID    PATH=((4F)),TYPE=CNC,PART=(LPB),SWITCH=00
```

Control unit and device definition for the 2216, with logical addressing = 1 for 2216A:

```
CNTLUNIT CUNUMBR=500,PATH=30,UNIT=3172,LINK=C1,      X
          UNITADD=(00,32),CUADD=1
IODEVICE ADDRESS=(500,32),CUNUMBR=500,UNIT=SCTC,    X
          UNITADD=((00,32))
```

Control unit and device definition for the 2216 with logical addressing = 2 for 2216A:

```
CNTLUNIT CUNUMBR=600,PATH=4F,UNIT=3172,LINK=C1,      X
          UNITADD=(00,32),CUADD=2
IODEVICE ADDRESS=(600,32),CUNUMBR=600,UNIT=SCTC,    X
          UNITADD=((00,32))
```

Control unit and device definition for the 2216, with logical addressing = 1 for 2216B:

```
CNTLUNIT CUNUMBR=620,PATH=4F,UNIT=3172,LINK=C6,      X
          UNITADD=(20,32),CUADD=1
IODEVICE ADDRESS=(620,32),CUNUMBR=620,UNIT=SCTC,    X
          UNITADD=((20,32))
```

The IOCP macroinstructions in the example:

- Assign a CHPID to logical partitions LPA and LPB.
- Define channel path 30 to the 2216 for partition LPA and channel path 4F for partition LPB.
- Identify channel type as an ESCON channel (CNC).
- Assign the two CHPIDs to ESCD switch number 00.
- Associate control unit numbers 500 and 600 to logical addresses 1 and 2 on 2216A and control unit number 620 to logical address 1 on 2216B.

## Planning Host Definition

- Assign link address C1 to control units 500 and 600 and link address C6 to control unit 620.
- Define unit addresses (subchannels) 00 through 1F to control units 500 and 600 and unit addresses 20 through 3F to control unit 620.
- Identify each control unit as an SCTC device.

### Considerations:

1. The address range for each 2216 must be contiguous pairs of addresses for TCP/IP programs and a single address for VTAM. TCP/IP programs require even-odd pairs and VTAM accepts an even or odd address.

The allowable device address range is 00 through FF. The 2216 address range is limited to 32 addresses, and only requires that the addresses defined at the host computer map to the address or addresses configured in the 2216. The address range can extend beyond the addresses actually used, but cannot overlap addresses of other control units cabled to the same CHPID or channel.

2. The ESCON channel mode of operation can be type CNC for basic ESCON channel mode or CVC if there is an ESCON Converter attached.
3. The IODEVICE UNIT parameter should be set to SCTC.
4. The LINK number specifies the link address (ESCD port number) to which the 2216 is connected. When two ESCDs are connected in series, the link address must be the port number of the ESCD that has the dynamic connection and to which the 2216 is attached.
5. The logical address (CUADD) must be unique for a given path between a host channel and a 2216.

### Example IOCP Definition for the EMIF Host

Figure 1-12 shows an example of an ESCON configuration using the ESCON Multiple Image Facility (EMIF). The S/390 host is divided into two logical partitions (LP): LPA and LPB. Both LPA and LPB are connected on path 30 to 2216 A through switch 00.

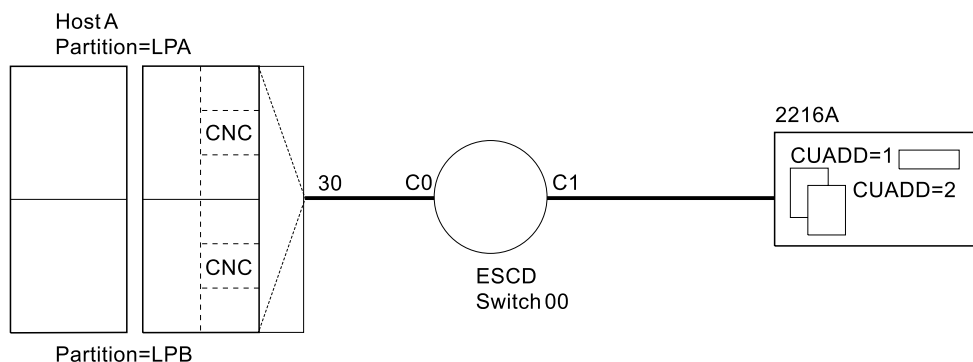

Figure 1-12. EMIF Host Configuration Example

The following example definitions match Figure 1-12:

Channel path definitions:

```
CHPID      PATH=((30)),TYPE=CNC,PART=(LPA,LPB),SWITCH=00
```

Control unit and device definition for the 2216, with logical addressing = 1 for 2216A:

```

CNTLUNIT  CUNUMBR=500,PATH=30,UNIT=3172,LINK=C1,          X
           UNITADD=(00,32),CUADD=1
IODEVICE  ADDRESS=(500,32),CUNUMBR=500,UNIT=SCTC,        X
           UNITADD=((00,32))
    
```

Control unit and device definition for the 2216, with logical addressing = 2 for 2216A:

```

CNTLUNIT  CUNUMBR=620,PATH=30,UNIT=3172,LINK=C1,          X
           UNITADD=(20,32),CUADD=2
IODEVICE  ADDRESS=(620,32),CUNUMBR=620,UNIT=SCTC,        X
           UNITADD=((20,32))
    
```

The IOCP macroinstructions in the example:

- Assign a CHPID to logical partitions LPA and LPB
- Define channel path 30 to the 2216 to be shared by partition LPA and partition LPB.
- Identify channel type as an ESCON channel (CNC)
- Assign the CHPID to ESCD switch number 00
- Associate control unit numbers 500 to logical address 1 and 620 to logical address 2 on 2216A
- Assign link address C1 to control units 500 and 620
- Define unit addresses (subchannels) 00 through 1F to control unit 500 and 20 through 3F to control unit 620
- Identify each control unit as an SCTC device.

### Considerations:

1. The address range for each 2216 must be contiguous pairs of addresses for TCP/IP programs and a single address for VTAM. TCP/IP programs require even-odd pairs and VTAM accepts an even or odd address.

The allowable device address range is 00 through FF. The 2216 address range is limited to 32 addresses, and only requires that the addresses defined at the host computer map to the address or addresses configured in the 2216. The address range can extend beyond the addresses actually used for the 2216, but cannot overlap addresses of other control units cabled to the same CHPID or channel.

2. The ESCON channel mode of operation can be type CNC for basic ESCON channel mode or CVC if there is an ESCON Converter attached.
3. The IODEVICE UNIT parameter should be set to SCTC.
4. The LINK number specifies the link address (ESCD port number) to which the 2216 is connected. When two ESCDs are connected in series, the link address must be the port number of the ESCD that has the dynamic connection and to which the 2216 is attached.
5. The logical address (CUADD) must be unique for a given path between a host channel and a 2216.
6. Each partition must have a unique logical address defined on the 2216.

### Defining the 2216 to the Operating System

The following definitions apply to a 2216 with an ESCON Channel Adapter.

#### 2216 Definition for VM/SP

The 2216 must be defined to a VM/SP operating system. This definition is accomplished by updating the real I/O configuration file (DMKRIO) with entries for the 2216 in the RDEVICE and the RCTLUNIT macros. In the following example, 640 is the base unit address and the size of the address range is 32.

```
RDEVICE ADDRESS=(640,32),DEVTYPE=3088
RCTLUNIT ADDRESS=640,CUTYPE=3088,FEATURE=32-DEVICE
```

#### 2216 Definition for VM/XA and VM/ESA

The 2216 must be defined to a VM/Extended Architecture (VM/XA or VM/ESA) operating system. This definition is accomplished by updating the real I/O configuration file (HCPRIO) with an entry for the 2216 in the RDEVICE macro. In the following examples, 640 and 2A0 are base control unit addresses. The address range size, as defined in the UCW or IOCP, is 8 in both examples.

The following example is a VM/XA HCPRIO definition:

```
RDEVICE ADDRESS=(640,8),DEVTYPE=CTCA
```

The following example is a VM/ESA HCPRIO definition:

```
RDEVICE ADDRESS=(2A0,8),DEVTYPE=CTCA
```

#### 2216 Definition for MVS/XA and MVS/ESA

The 2216 must be defined to an IBM Multiple Virtual Storage/Extended Architecture (MVS/XA) or MVS/ESA operating system. This definition is accomplished by updating the MVS Control Program with an entry for the 2216 in the IODEVICE macro.

For ESCON channels, an example IODEVICE macro is:

```
IODEVICE UNIT=SCTC,ADDRESS(540,8)
```

The base control unit address is 540 and the address range size, as defined in the UCW or IOCP, is 8.

#### 2216 Definition for MVS/ESA with HCD

The hardware configuration definition (HCD) component of MVS/ESA SP Version 4.2 and 4.3 with APAR #OY67361 offers an improved method of defining system hardware configuration for 2216. Several complex steps required for entering hardware configuration data can be accomplished using an interactive dialog with HCD.

The required configuration data for the 2216 is:

1. When using HCD, with APAR #OY67361, the 2216 is defined as (UNIT = 3172).
2. Without HCD, the 2216 is defined for ESCON channels as a serial CTC device (UNIT = SCTC).



**Notes:**

1. If you are using HCD for MVS Version 4 to define your ESCON host connection, you will need APAR # OY67361 to obtain the UIM support for the device definition (UNIT=3172).
2. When migrating your IOCP definition and operating system definitions to the HCD environment, it is important that all 2216 device statements be changed to device type (UNIT=3172).

**2216 Definition for VSE/ESA**

The 2216 must be defined to a VSE/ESA operating system. This definition is accomplished by supplying an ADD statement for each channel unit address at initial program load (IPL) time. Code the device type on the ADD statement as CTCA,EML as shown in the following example:

```
ADD 640,CTCA,EML
```

The base control unit address is 640 in the example. For the number of channel unit addresses added, increment the IOTAB storage macro by this count.

**Defining the 2216 to Host Programs**

The section has configuration definitions with samples of host definitions required to connect to the 2216 ESCON Channel Adapter.

**Configuring the Host for TCP/IP**

TCP is configured on a host by modifying the TCP/IP profile. The default name for the TCP/IP profile data set is TCPIP.PROFILE.TCPIP for MVS and PROFILE TCPIP for VM. Each channel connection requires:

- One LINK and one DEVICE statement in the TCP/IP profile
- An entry in the HOME statement
- Entries in the GATEWAY statement for the link to be used (if ROUTED is not being used)
- A START command for the device

**DEVICE and LINK statements:** The format of the DEVICE and LINK statements are:

```
DEVICE devicename LCS subchannel
LINK iplinkname LANtype LANnumber devicename
```

where:

- devicename* is a local name to distinguish devices. You need a START statement for this device name at the end of the TCP/IP profile as shown in "TCP/IP Commands - Example" on page 1-32.
- LCS subchannel* is the even subchannel of the two LCS subchannels that this connection to the 2216 will use.
- iplinkname* is a local name to distinguish LINKs. This name can help you identify which link is being configured.
- LANtype* is the type of link.
- LANnumber* is obtained from the 2216 by using the LIST NETS command of the appropriate NETWORK submenu.

## Planning Host Definition

**HOME Command:** Specify IP addresses for each channel connection using the following format:

```
HOME hostipadd iplinkname
```

where:

*hostipadd* is the host's IP address for this connection to the TCP/IP network.

*iplinkname* is the parameter defined by the LINK statement as described in "DEVICE and LINK statements" on page 1-31.

**GATEWAY Command:** Specify routing information if you are not using the ROUTED server.

```
GATEWAY network first hop driver packet size subn mask subn value
```

where:

*network* is the IP address for the network. The default value is *defaultnet*, which specifies a default routing entry for any network not explicitly routed.

*first hop* is the internet address that you can reach directly and that forwards messages to the destination. A value of = implies that messages are routed directly to the destination.

*driver* is the *iplinkname* defined by the LINK statement as described in "DEVICE and LINK statements" on page 1-31.

*packet size* is the maximum transmission unit in bytes for the network or host.

*subn mask* is a bit mask that defines the bits of the host field that make up the subnet field.

*subn value* is the value of the subnet field.

**START Command:** Start all the interfaces:

```
START devicename
```

where:

*devicename* is the parameter defined by the DEVICE statement as described in "DEVICE and LINK statements" on page 1-31.

### TCP/IP Commands - Example:

```
DEVICE LCS1 LCS 108
LINK TR1 IBMTR 0 LCS1
HOME
    16.51.136.199 TR1
GATEWAY
    DEFAULTNET 16.51.136.201 TR1 4000 0
START LCS1
```

### Sample 2216 Definition to TCP/IP for MVS or VM

The following is an example of TCP/IP definitions provided to the host computer in the TCP/IP Profile data set. The default name for the TCP/IP profile data set is TCPIP.PROFILE.TCPIP for MVS and PROFILE TCPIP for VM.

First, 2216 devices and links are defined to TCP/IP.

There is a DEVICE statement for each subchannel pair that is used to access 2216s. The first address specified must be an *even* address. In this example, two devices (subchannel pairs) are defined: one at address 640 and one at address

642. These devices could be in the same or different 2216s. A device type of LCS (LAN Channel Station) is used to define these devices to TCP/IP.

There is a LINK statement for each LAN adapter that is accessible from these devices. In this example, one Ethernet/802.3 Adapter is assigned to the device using subchannels 640 and 641, and two Token-Ring adapters are assigned to the device using 642 and 643. These two Token-Ring adapters are in the same 2216 because they are associated with the same device. The LINK number for each adapter (0 and 1 in this example) is assigned by the 2216 when you add an adapter to a profile. When sharing a LAN adapter with VTAM, the ADAPNO value in the VTAM definition and the LINK number in the TCP/IP definition will be the same number, which is assigned by the 2216.

**Note:** Two subchannel addresses are required for sending and receiving (for example, 640 and 641), but only the first address is defined.

```
DEVICE LCS1 LCS 640
LINK ETH1 ETHERor802.3 0 LCS1
DEVICE LCS2 LCS 642
LINK TR1 IBMTR 0 LCS2
LINK TR2 IBMTR 1 LCS2
```

**Note:** In this example, 0 and 1 are the LAN numbers for these connections.

This section of the example TCP/IP profile defines the local host internet addresses:

```
HOME
193.5.2.1 ETH1
130.50.75.1 TR1
130.50.76.1 TR2
```

This section of the example TCP/IP profile represents the LAN/WAN gateway definition:

```
GATEWAY
Network First hop Driver Packet Size Subnet mask Subnet value
193.5.2 = ETH1 1500 0
130.50 = TR1 2000 0.0.255.0 0.0.75.0
130.50 = TR2 2000 0.0.255.0 0.0.76.0
```

This section of the example TCP/IP profile activates the LCS devices:

```
START LCS1
START LCS2
```

The following examples illustrate various ways that LAN adapters can be specified and linked to subchannel pairs in the TCP/IP profile.

Two LCS devices for the two subchannel pairs 40,41 and 42,43 and four LAN adapters are defined in the 2216 as follows:

```
DEVICE LCS1 LCS 640
LINK ETH1 ETHERNET 0 LCS1
LINK ETH2 ETHERNET 1 LCS1
DEVICE LCS3 LCS 642
LINK TRN1 IBMTR 0 LCS2
LINK TRN2 IBMTR 1 LCS2
```

## Planning Host Definition

Four LCS devices for the four subchannel pairs 40,41; 42,43; 44,45; and 46,47 and four LAN adapters are defined in the 2216 as follows:

```
DEVICE LCS1 LCS 640
LINK ETH1 ETHERNET 0 LCS1
DEVICE LCS2 LCS 642
LINK ETH2 ETHERNET 1 LCS2
DEVICE LCS3 LCS 644
LINK TRN1 IBMTR 0 LCS3
DEVICE LCS4 LCS 646
LINK TRN2 IBMTR 1 LCS4
```

One LCS device for the subchannel pair 40,41 and four LAN adapters are defined in the 2216 as follows:

```
DEVICE LCS1 LCS 640
LINK ETH1 ETHERNET 0 LCS1
LINK ETH2 ETHERNET 1 LCS1
LINK ETH3 ETHERNET 2 LCS1
LINK ETH4 ETHERNET 3 LCS1
```

For more information about TCP/IP definitions, refer to the TCP/IP publications listed in “Related Publications” on page xiv.

### VTAM Control Blocks Used to Configure LSA at the Host

Configuring the VM or MVS host requires entries in two VTAM control blocks:

- External communication adapter (XCA) major node definition file
- Switched major node configuration file

For more information on configuring VTAM, refer to *VTAM Resource Definition Reference*.

**XCA Major Node Definition File - Sample:** Defining an XCA major node requires coding VTAM definition statements to define the following characteristics:

- Node type (VBUILD definition statement)
- Port used by the LAN (PORT definition statement)
- Switched lines attached through the 2216 ESCON Channel Adapter (GROUP, LINE, and PU definition statements)

You must code a VBUILD definition statement and a PORT definition statement for the major node, and code GROUP, LINE, and PU definition statements for minor nodes.

You must also assign service access points (SAPs) to be used for each virtual channel to a LAN or emulated LAN.

**Switched Major Node Definition File - Sample:** The switched major node definition file defines the workstations that VTAM will be able to access through the 2216 ESCON Channel Adapter, and identifies:

- Node type (VBUILD definition statement)
- Network Resources (PU and LU definition statements)

To define the 2216 LAN/WAN gateway to VTAM, the appropriate LAN adapter in the IBM 2216 must be associated with a subchannel address. This association is defined to VTAM in a major node definition that is supported by VTAM Version 3 Release 4 and VTAM Version 4 Release 1.

### Configuring an LSA Direct Connection at the VTAM Host

Configuring the VM or MVS host requires entries in two VTAM control blocks, the XCA Major Node Definition File and the Switched Major Node Definition File. See "VTAM Control Blocks Used to Configure LSA at the Host" on page 1-34 for a description of the purpose of these control blocks and references to VTAM publications.

#### *XCA Major Node Definition File - Sample*

```
ROUTE6B1 VBUILD TYPE=XCA
PORT6B1 PORT CUADDR=0CB,ADAPNO=0,TIMER=60,SAPADDR=08, C
          MEDIUM=RING
GRP6B1 GROUP DIAL=YES
*****
LN06B001 LINE ANSWER=ON,CALL=INOUT,ISTATUS=ACTIVE
PU06B001 PU ISTATUS=ACTIVE
```

#### Notes:

1. ADAPNO is the LAN number for the 2216 interface.
2. CUADDR is the channel address. This corresponds to the Device Address (two hexadecimal characters defining the lower byte of the channel address) for the 2216 interface.
3. MEDIUM=RING for Token Ring and MEDIUM=CSMACD for Ethernet. This corresponds to the value specified for LANtype for the 2216 interface.

#### *Switched Major Node Definition File - Sample*

```
PS06SW VBUILD TYPE=SWNET
PS06PU PU ADDR=01,IDBLK=05D,IDNUM=54445,MAXOUT=7,PACING=0,VPACING=0, C
          SSCPFM=USSSCS,MAXDATA=4105,MODETAB=LMT3270,MAXPATH=1, C
          ANS=CONT,ISTATUS=ACTIVE,DLOGMOD=B22NNE
PS06LU2 LU LOCADDR=02
PS06LU3 LU LOCADDR=03
PS06LU4 LU LOCADDR=04
PS06LU5 LU LOCADDR=05
```

### Configuring an LSA APPN Connection at the VTAM host

With the following exceptions, APPN is configured over the MPC+ interface as it is over other interface types:

- On the APPN "add port" command, specify link type MPC.
- On the APPN "add port" command, you may specify the MPC+ sequencing interval timer.

Configuring the VM or MVS host requires entries in two VTAM control blocks, the XCA Major Node Definition File and the Switched Major Node Definition File. See "VTAM Control Blocks Used to Configure LSA at the Host" on page 1-34 for a description of the purpose of these control blocks and references to VTAM publications.

#### *XCA Major Node Definition File - Sample*

```
P15AP63X VBUILD TYPE=XCA
PORT63X PORT CUADDR=0CD,ADAPNO=0,TIMER=60,SAPADDR=04, C
          MEDIUM=CSMACD
GRP63X GROUP DIAL=YES
*****
LN630403 LINE ANSWER=ON,CALL=INOUT,ISTATUS=ACTIVE
PU630403 PU ISTATUS=ACTIVE
```

### Notes:

1. ADAPNO is the LAN number for the 2216 interface.
2. CUADDR is the channel address. This corresponds to the Device Address (two hexadecimal characters defining the lower byte of the channel address) for the 2216 interface.
3. MEDIUM=RING for Token Ring and MEDIUM=CSMACD for Ethernet. This corresponds to the value specified for LANtype for the 2216 interface.

### **Switched Major Node Definition File - Sample**

```
LS601  VBUILD TYPE=SWNET
CS601  PU  ADDR=02,CPNAME=C210,MAXOUT=7,PACING=0,VPACING=0,          C
        CPCP=YES,MAXDATA=4105,MODETAB=LMT3270,MAXPATH=10,         C
        CONNTYPE=APPN,DYNLU=YES
```

### **Configuring an LSA DLSw Connection at the VTAM Host**

Configuring the VM or MVS host requires entries in two VTAM control blocks, the XCA Major Node Definition File and the Switched Major Node Definition File. See "VTAM Control Blocks Used to Configure LSA at the Host" on page 1-34 for a description of the purpose of these control blocks and references to VTAM publications.

### **XCA Major Node Definition File - Sample**

```
P15AP60X VBUILD TYPE=XCA
PORT60X  PORT  CUADDR=0CC,ADAPNO=1,TIMER=60,SAPADDR=04,          C
          MEDIUM=CSMACD
GRP60X   GROUP DIAL=YES
*****
LN600403 LINE  ANSWER=ON,CALL=INOUT,ISTATUS=ACTIVE
PU600403 PU    ISTATUS=ACTIVE
LN600404 LINE  ANSWER=ON,CALL=INOUT,ISTATUS=ACTIVE
PU600404 PU    ISTATUS=ACTIVE
```

### Notes:

1. ADAPNO is the LAN number for the 2216 interface.
2. CUADDR is the channel address. This corresponds to the Device Address (two hexadecimal characters defining the lower byte of the channel address) for the 2216 interface.
3. MEDIUM=RING for Token Ring and MEDIUM=CSMACD for Ethernet. This corresponds to the value specified for LANtype for the 2216 interface.

### **Switched Major Node Definition File - Sample**

```
PSK5SW  VBUILD TYPE=SWNET
PSK5PU  PU  ADDR=03,IDBLK=05D,IDNUM=07251,MAXOUT=7,PACING=0,VPACING=0,  C
        DLOGMOD=B22NNE,                                           C
        SSCPFM=USSSCS,MAXDATA=2000,MODETAB=LMT3270
PSK5LU2 LU  LOCADDR=02
PSK5LU3 LU  LOCADDR=03
PSK5LU4 LU  LOCADDR=04
PSK5LU5 LU  LOCADDR=05
PSK5LU6 LU  LOCADDR=06
```

## Configuring an LSA DLSw Local Conversion at the VTAM Host

Configuring the VM or MVS host requires entries in two VTAM control blocks, the XCA Major Node Definition File and the Switched Major Node Definition File. See “VTAM Control Blocks Used to Configure LSA at the Host” on page 1-34 for a description of the purpose of these control blocks and references to VTAM publications.

### *XCA Major Node Definition File - Sample*

```
P15AP60X VBUILD TYPE=XCA
PORT60X PORT CUADDR=0CC,ADAPNO=1,TIMER=60,SAPADDR=04, C
          MEDIUM=CSMACD
GRP60X GROUP DIAL=YES
*****
LN600403 LINE ANSWER=ON,CALL=INOUT,ISTATUS=ACTIVE
PU600403 PU ISTATUS=ACTIVE
LN600404 LINE ANSWER=ON,CALL=INOUT,ISTATUS=ACTIVE
PU600404 PU ISTATUS=ACTIVE
```

#### Notes:

1. ADAPNO is the LAN number for the 2216 interface.
2. CUADDR is the channel address. This corresponds to the Device Address (two hexadecimal characters defining the lower byte of the channel address) for the 2216 interface.
3. MEDIUM=RING for Token Ring and MEDIUM=CSMACD for Ethernet. This corresponds to the value specified for LANtype for the 2216 interface.

### *Switched Major Node Definition File - Sample*

```
PS06SW VBUILD TYPE=SWNET,MAXDLUR=20
PS06PU PU ADDR=01,IDBLK=05D,IDNUM=54445,MAXOUT=7,PACING=0,VPACING=0, C
          SSCPFM=USSSCS,MAXDATA=4105,MODETAB=LMT3270,MAXPATH=1, C
          ANS=CONT,ISTATUS=ACTIVE,DLOGMOD=B22NNE
PS06LU2 LU LOCADDR=02
PS06LU3 LU LOCADDR=03
PS06LU4 LU LOCADDR=04
PS06LU5 LU LOCADDR=05

PSK5SW VBUILD TYPE=SWNET
PSK5PU PU ADDR=03,IDBLK=05D,IDNUM=07251,MAXOUT=7,PACING=0,VPACING=0, C
          DLOGMOD=B22NNE, C
          SSCPFM=USSSCS,MAXDATA=2000,MODETAB=LMT3270
PSK5LU2 LU LOCADDR=02
PSK5LU3 LU LOCADDR=03
PSK5LU4 LU LOCADDR=04
PSK5LU5 LU LOCADDR=05
PSK5LU6 LU LOCADDR=06
```

The following examples show XCA and SWNET macros that define the LAN major node for a token-ring adapter and an Ethernet adapter, respectively. In the examples:

- GROUP1T, GROUP1E, and GROUP1F represent resources connected to the LAN that require a VBUILD TYPE=SWNET.
- GROUP2T, GROUP2E, and GROUP2F represent a connection for the PU 5 node.

The mode table and default mode entries are examples only. Be sure to use the mode tables and mode entries defined in your installation.

## Planning Host Definition

```
TRLAN1  VBUILD TYPE=XCA
PORT1   PORT   MEDIUM=RING,ADAPNO=0,CUADDR=644,TIMER=60,SAPADDR=4
GROUP1T GROUP   DIAL=YES      * Switched Attachment
LINE1TA LINE   ANSWER=ON,CALL=INOUT,ISTATUS=ACTIVE
PU1TA  PU     ISTATUS=ACTIVE
LINE1TB LINE   ANSWER=ON,CALL=INOUT,ISTATUS=ACTIVE
PU1TB  PU     ISTATUS=ACTIVE
GROUP2T GROUP   DIAL=NO      * Leased Definition
LINE2T  LINE   USER=SNA     * Multi-domain Connection
PU2T   PU     MACADDR=400000000001,TGN=1,SUBAREA=2,SAPADDR=4,PUTYPE=5
```

```
ENLAN2  VBUILD TYPE=XCA
PORT2   PORT   MEDIUM=CSMACD,ADAPNO=0,CUADDR=645,TIMER=60,SAPADDR=4
GROUP1E GROUP   DIAL=YES      * Switched Attachment
LINE1EA LINE   ANSWER=ON,CALL=INOUT,ISTATUS=ACTIVE
PU1EA  PU     ISTATUS=ACTIVE
LINE1EB LINE   ANSWER=ON,CALL=INOUT,ISTATUS=ACTIVE
PU1EB  PU     ISTATUS=ACTIVE
GROUP2E GROUP   DIAL=NO      * Leased Definition
LINE2E  LINE   USER=SNA     * Multi-domain Connection
PU2E   PU     MACADDR=400000000002,TGN=2,SUBAREA=2,SAPADDR=4,PUTYPE=5
```

The following examples are the switched major node definitions.

```
LS100SW VBUILD TYPE=SWNET,MAXGRP=400,MAXNO=400
CS100001 PU  ADDR=01,PUTYPE=2,MAXPATH=4,ANS=CONT,DLOGMOD=B22NNE,
          ISTATUS=ACTIVE,MAXDATA=521,IRETRY=YES,MAXOUT=7,
          PASSLIM=5,IDBLK=111,IDNUM=00001,MODETAB=LMT3270
          PATH DIALNO=0104400000000004,GRPNM=GROUP1T
S00102  LU  LOCADDR=2
CS100002 PU  ADDR=02,PUTYPE=2,MAXPATH=4,ANS=CONT,DLOGMOD=B22NNE,
          ISTATUS=ACTIVE,MAXDATA=521,IRETRY=YES,MAXOUT=7,
          PASSLIM=5,CPNAME=MYNS2,MODETAB=LMT3270
          PATH DIALNO=0104400000000005,GRPNM=GROUP1T
S00200  LU  LOCADDR=0,DLOGMOD=LU62MODE
S00202  LU  LOCADDR=2

CS100003 PU  ADDR=03,PUTYPE=2,MAXPATH=4,ANS=CONT,DLOGMOD=B22NNE,
          ISTATUS=ACTIVE,MAXDATA=521,IRETRY=YES,MAXOUT=7,
          PASSLIM=5,IDBLK=111,IDNUM=00003,MODETAB=LMT3270
          PATH DIALNO=0104400000000006,GRPNM=GROUP1E
S00302  LU  LOCADDR=2
CS100004 PU  ADDR=04,PUTYPE=2,MAXPATH=4,ANS=CONT,DLOGMOD=B22NNE,
          ISTATUS=ACTIVE,MAXDATA=521,IRETRY=YES,MAXOUT=7,
          PASSLIM=5,IDBLK=111,IDNUM=00004,MODETAB=LMT3270
          PATH DIALNO=0104400000000007,GRPNM=GROUP1E
S00402  LU  LOCADDR=2

CS100005 PU  ADDR=05,PUTYPE=2,MAXPATH=4,ANS=CONT,DLOGMOD=B22NNE,
          ISTATUS=ACTIVE,MAXDATA=521,IRETRY=YES,MAXOUT=7,
          PASSLIM=5,IDBLK=111,IDNUM=00005,MODETAB=LMT3270
          PATH DIALNO=0104400000000008,GRPNM=GROUP1F
S00502  LU  LOCADDR=2
CS100006 PU  ADDR=06,PUTYPE=2,MAXPATH=4,ANS=CONT,DLOGMOD=B22NNE,
          ISTATUS=ACTIVE,MAXDATA=521,IRETRY=YES,MAXOUT=7,
          PASSLIM=5,IDBLK=111,IDNUM=00006,MODETAB=LMT3270
          PATH DIALNO=0104400000000005,GRPNM=GROUP1F
S00602  LU  LOCADDR=2
```



For more information about VTAM definitions, refer to the VTAM publications listed in "Related Publications" on page xiv.

### Configuring the VTAM Host for MPC+

Configuring the VTAM host requires entries in two VTAM control blocks, the Local SNA Major Node and the Transport Resource (TRL) Major Node, and a change to the VTAM start-up parameters. For more information on configuring VTAM, refer to *VTAM Resource Definition Reference*.

**Local SNA Major Node:** Use the following definition statements to configure a local SNA major node in VTAM:

```
UTYLSNA VBUILD TYPE=LOCAL
UTYHCC1 PU      TRLE=UHCC1,XID=YES,CONNTYPE=APPN,CPCP=YES,HPR=YES
```

### Transport Resource List (TRL) Major Node:

```
BC4UTRL VBUILD TYPE=TRL
UHCC1   TRLE LNCTL=MPC,           C
        MAXBFRU=8,                C
        READ=(xxx1,xxx2,...),      C
        WRITE=(yyy1,yyy2,...),     C
        REPLYTO=3.0
```

where:

xxx1,xxx2,... are the read subchannel numbers.

yyy1,yyy2,... are the write subchannel numbers.

The read and write subchannel numbers must match those configured on the 2216.

**Note:** A "read" subchannel to VTAM is a "write" subchannel to the 2216 and a "write" subchannel to VTAM is a "read" subchannel to the 2216.

**VTAM Start-up Parameters:** In the VTAM initialization file ATCSTRxx, where xx is defined by the user, define a network node:

```
NODETYPE=NN
```

Since high-performance routing (HPR) is being used, you also should add to this file:

```
HPR=YES
```

**Note:** Only APPN HPR is supported across the MPC+ interface. APPN ISR is not supported.

---

## Planning for 2216 Support

This section describes considerations for support of the 2216 and ESCON Channel Adapter in a network. Analyzing and resolving a communications problem between an ESCON Channel Adapter and a host or LAN may require you to initiate problem resolution procedures for the 2216.

The problem can be:

- A configuration or host definition problem
- A 2216 hardware or software problem
- A channel problem between the 2216 and the host
- A host program, resource, or hardware problem

- A LAN adapter, access unit, or other hardware malfunction
- A LAN workstation program or resource problem
- A communication problem between the 2216 and the LAN
- A problem using hardware or software

Indications of problems come from user reports, or indicators and displayed codes on the 2216 and other devices, or messages displayed by programs. These indications help you determine whether the problem is a hardware, software, or user problem. They also help you isolate the location (2216, LAN, host) and component (device, adapter, channel, or program) of the network that has the problem.

Determining the nature of the problem often indicates which procedures, tools, or additional information may be needed for resolution. The same tools, procedures, and information can also indicate the need to call for service. Problem resolution and service interfaces (NetView, SNMP Client) are available to the customer.

### 2216 ESCON Channel Adapter Problem Analysis and Resolution

The 2216 ESCON Channel Adapter problem isolation procedure described in Chapter 3, “Testing the ESCON Channel Adapter” on page 3-1 and Appendix A, “Diagnostic Testing of the ESCON Channel Adapter” on page A-1 should help you correct the problem, if possible, and determine when to call for service.

You can reconnect loose adapter cables and power cords. You must call for service on channel cables.

For a description of ELS Messages, see Appendix D, “ELS Messages” on page D-1.

For general information for the 2216, refer to *Service and Maintenance Manual* and to *Event Logging System Messages Guide*.

### Reconfiguration

Whenever your network grows, shrinks, or rearranges, you may need to reconfigure host programs and 2216 profiles to:

- Balance network traffic and workload
- Migrate to new versions or releases of host programs
- Migrate to new versions or releases of the 2216
- Recreate working diskettes
- Change host SYSGENS

See Chapter 4, “Configuring the ESCON Channel Adapter” on page 4-1 and Chapter 5, “Monitoring the ESCON Channel Adapter” on page 5-1 for information related to the 2216. For information on host programs, refer to the publications listed in “Related Publications” on page xiv.

---

## Chapter 2. Installing the ESCON Channel Adapter

These instructions explain how to complete physical installation of the 2216 ESCON Channel Adapter.

Perform the following steps to complete installation of the ESCON Channel Adapter before testing.

- 1** Unpack the ESCON Channel Adapter.
- 2** Check to be sure that you have the necessary tools, parts, and supplies to complete the installation.
- 3** Select an appropriate adapter slot.
- 4** Power off the IBM 2216.
- 5** Orient the adapter.
- 6** Insert the adapter.
- 7** Seat the adapter.
- 8** Connect the adapter cable.
- 9** Position the adapter cable.

---

### Unpack and Verify

Unpack the ESCON Channel Adapter and wrap plug enclosed with this setup guide.

To complete setup and test you will require an IBM 2216 with an suitable slot, a wrap plug (PN 5605670), and one standard-length IBM duplex-to-duplex 62.5/125-micrometer multimode fiber-optic jumper cable (PN 14F3797).

The cable for each IBM 2216 ESCON Channel Adapter must be separately ordered as cable group #3797 or as part #14F3797 in the following standard lengths:

- 4 meters (12 ft)
- 7 meters (20 ft)
- 22 meters (70 ft)
- 31 meters (100 ft)
- 46 meters (150 ft)
- 61 meters (200 ft)
- 77 meters (250 ft)
- 92 meters (300 ft)
- 107 meters (350 ft)
- 122 meters (400 ft)

For additional information on planning for IBM 2216 ESCON Channel Adapter cable installations, refer to *Fiber Optic Link Planning*, GA23-0367.

### Select an Appropriate Adapter Slot

The ESCON Channel Adapter can be installed in the IBM 2216 with the following conditions and restrictions:

- 1** The IBM 2216 supports a maximum of four ESCON adapters (FC 2287).
- 2** If the 2-port Token-Ring (FC 2280) or 2-port Ethernet (FC 2281) adapter is plugged into slot 3 and active, then slot 4 cannot be used.
- 3** If the 2-port Token-Ring (FC 2280) or 2-port Ethernet (FC 2281) is plugged into slot 4 and active, then slot 3 cannot be used.
- 4** If the 2-port Token-Ring (FC 2280) or 2-port Ethernet (FC 2281) adapter is plugged into slot 7 and active, then slot 8 cannot be used.
- 5** If the 2-port Token-Ring (FC 2280) or 2-port Ethernet (FC 2281) adapter is plugged into slot 8 and active, then slot 7 cannot be used.

Besides these conditions and restrictions, IBM 2216 units assembled at the factory follow certain plugging rules. Refer to Appendix B, "Factory Plugging Defaults for the ESCON Channel Adapter" on page B-1 for information which may be pertinent to your particular slot selection for one or more ESCON Channel Adapters.

---

### Power Off the IBM 2216

Power off the IBM 2216 and then complete the steps outlined in the following section, "Orient the Adapter." Refer to *IBM 2216 Planning and Setup Guide* for related information.

---

## Orient the Adapter

Notice the notches at the adapter card's angled corners and position them on the left as illustrated.

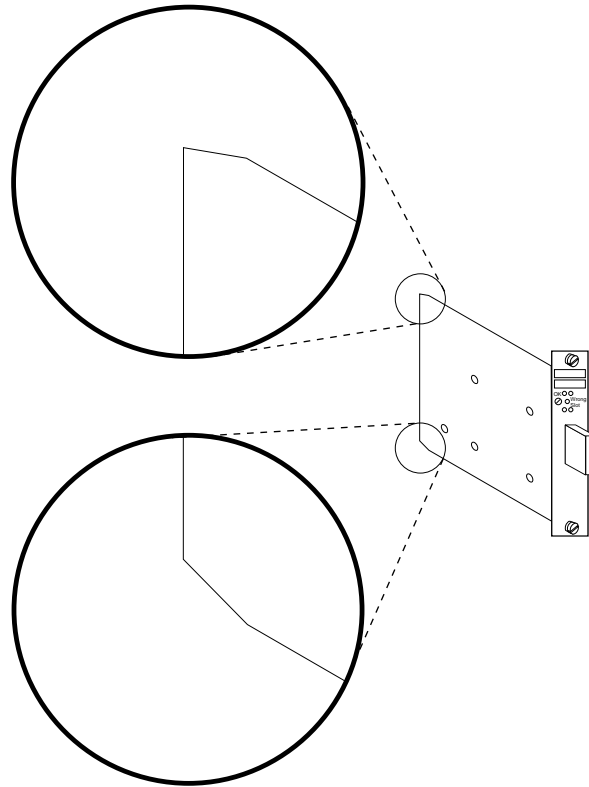

---

### Insert the Adapter

Carefully position the notches of the adapter card in the appropriate adapter slot's upper and lower rails. Then, guide the adapter forward on the rails as pictured.

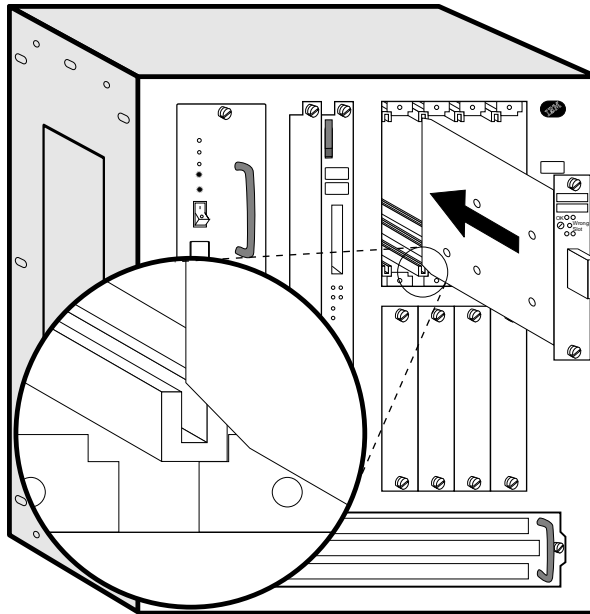

## Seat the Adapter

When the adapter card's thumbscrews contact the receiving holes on the front of the IBM 2216, press and turn each thumbscrew clockwise simultaneously only until the adapter is firmly seated.

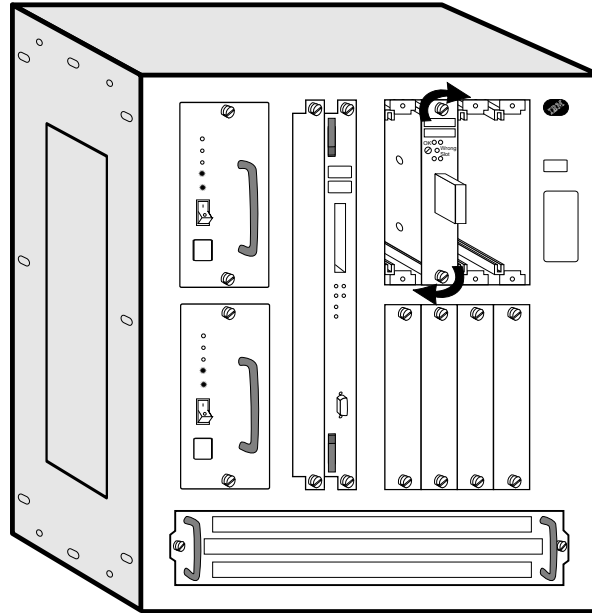

**Attention:** You must turn the adapter's thumbscrews simultaneously when seating or unseating the adapter during installation or removal. By doing so, you prevent stripping the thumbscrews. If you strip the thumbscrews, you may not be able to seat or reseat the adapter properly.

---

### Connect the Adapter Cable

Connect the ESCON fiber optic cable to the adapter by inserting the connector into the adapter until a snap is heard.

**Note:** The connector is keyed to prevent inserting it incorrectly.

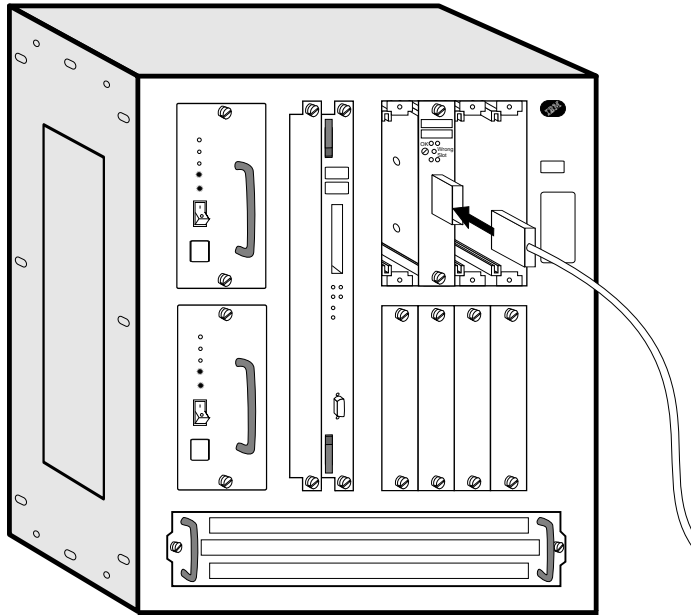



## Position the Adapter Cable

Guide the cable attached to the adapter through the IBM 2216's wiring harness as detailed in the figure below.

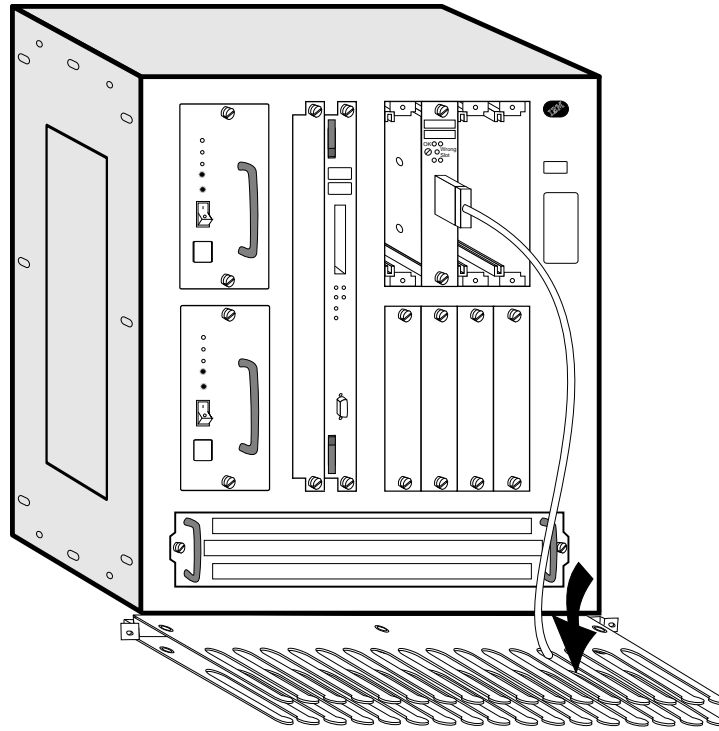



---

## Chapter 3. Testing the ESCON Channel Adapter

Complete the following steps to test the ESCON Channel Adapter.

- Power on the IBM 2216.
- Run diagnostics on the new ESCON adapter.
- Run the light test on the new fiber optic cable.

Refer to Appendix A, “Diagnostic Testing of the ESCON Channel Adapter” on page A-1 for additional information on the use of IBM 2216 operational diagnostics.

Refer to Appendix C, “LED Indicators for the ESCON Channel Adapter” on page C-1 for information on interpreting IBM 2216 ESCON Channel Adapter LEDs.

---

### Power On the IBM 2216

Power on the IBM 2216. Refer to the *IBM 2216 Planning and Setup Guide*, GA27-4105 for information on how to power on the IBM 2216.

Messages equivalent to the following appear on the TTY console after powering on the IBM 2216.

```
PRESENCE_MGR> LIC280 detected in slot 1
PRESENCE_MGR> LIC287 detected in slot 3
PRESENCE_MGR> LIC287 detected in slot 4

Please press the space bar to obtain the console.

Disk Load: Using bank B and config number 3
```

Press the space bar.

```
Console granted to this interface

*
```

**Note:** The operator interface described in this chapter is the *Command Line Interface*, also known as the *Operator Control Module (OPCON)*. This interface appears when you Telnet into the service port of the IBM 2216 or when you attach an ASCII terminal emulator to the service port either remotely or locally. See the *IBM 2216 Planning and Setup Guide*, GA27-4105 for information and details on each way to access the IBM 2216 console.

## Run Diagnostics on the New ESCON Adapter

**1** Issue **diags** at the command prompt to enter the Diagnostic Menu.

```
* diags

                                     Screen 1 of 1
                               Diagnostic Menu

Select from the following list of functions:

< 1. The Device Status Page >
  shows operational and diagnostic status for each of the installed adapters.
  From this page you can also link to the Test Control Page for each adapter.

< 2. The Diagnostic Test History Log >
  contains a summary of recent testing activity.

< 3. The Diagnostic Error Log >
  contains error information for recent diagnostic tests that have detected
  errors.

First time users should review the < 4. Introduction > to using the
diagnostics.

Select (1-4 or E=Exit Diagnostics ):1
```

**2** Enter **1** to access the Device Status Page (option 1).

```
                                     Screen 1 of 1
                               Device Status Page

For more information and Test Control Menus for devices...
Select from the following list:

   Device      Location
   Token Ring  Slot 1  Multi-Port  Adapter  Status
< 1. Token Ring > Slot 1  Port 1     Net # 0  ENABLED
< 2. Token Ring > Slot 1  Port 2     Net # 1  ENABLED
< 3. ESCON >    Slot 3  Single Port Net # 2  ENABLED
< 4. ESCON >    Slot 4  Single Port  --     NOT CONFIGURED

Some of the devices are not currently available for testing. This can occur
when a test is not available for the device or when the device must be
configured in order to be tested.

Select (1-4 or B=Back R=Refresh H=Help ): 4
```

### 3 Enter 4 to test the ESCON channel adapter in slot 4.

Notice that the status of the ESCON adapter installed in slot 4 is NOT CONFIGURED.

```

                                Test Control Menu
                                Screen 1 of 1

LIC 287 - ESCON Channel Adapter, Slot 4

Operational Status  Diagnostic Status  Fault Status  Network Connection
NOT CONFIGURED      INACTIVE      UNKNOWN      UNKNOWN

Select from the following:
  Disable Device
  Enable Device
  < 1. Run Default Test >
  < 2. Run Interactive Test >
  < 3. Loop Test - stop on first error >
  < 4. Loop Test - Log all errors >
  Stop Looping Test
  < 5. View Test History Log >
  < 6. View Hardware Error Log >

Select (1-6 or B=Back R=Refresh H=Help ):2
    
```

### 4 Enter 2 to select Run Interactive Test and invoke the Test Options menu.

```

                                Test Options
                                Screen 1 of 1

LIC 287 - ESCON Channel Adapter, Slot 4

Operational Status  Diagnostic Status  Fault Status  Network Connection
NOT CONFIGURED      MESSAGE          UNKNOWN      UNKNOWN

Do not remove this device while testing.
Select one of the following test options:
* < 1. Run all tests excluding external wrap test >
* < 2. Run all tests including external wrap test >
  Individual tests:
* < 3. PCI BUS >
* < 4. PROCESSOR >
* < 5. MEMORY >
* < 6. MEMORY PROT >
* < 7. TIMER >
* < 8. AIB >
* < 9. WRAP PLUG >
* <10. OPTICAL POWER >
* <11. LIGHT RECEPTION >

Select (1-11 or B=Back R=Refresh H=Help ):2
    
```

## Testing the ESCON Channel Adapter

- 5** Type **2** to select Run all tests including external wrap test. At this point, the following panel appears.

```
Screen 1 of 1
Setup For Wrap Test
LIC 287 - ESCON Channel Adapter, Slot 4
Operational Status Diagnostic Status Fault Status Network Connection
NOT CONFIGURED TESTING UNKNOWN UNKNOWN
Do not remove this device while testing.
Install the wrap plug (PN 5605670) on the ESCON adapter located in slot 4
Confirm that the wrap plug is installed.
< 1. Start test. >
Select (1 or B=Back R=Refresh H=Help ):1
```

- 6** Attach the wrap plug, then enter **1** to Start test.

Because this is a long-running test, the Test Control Menu will be displayed again. Note that the Diagnostic Status is TESTING. This indicates that the tests are running and will take about three minutes to complete.

```
Screen 1 of 1
Test Control Menu
LIC 287 - ESCON Channel Adapter, Slot 4
Operational Status Diagnostic Status Fault Status Network Connection
NOT CONFIGURED TESTING UNKNOWN UNKNOWN
Do not remove this device while testing.
Select from the following:
  Disable Device
  Enable Device
  Run Default Test
  Run Interactive Test
  Loop Test - stop on first error
  Loop Test - Log all errors
  Stop Looping Test
  < 1. View Test History Log >
  < 2. View Hardware Error Log >
Select (1-2 or B=Back R=Refresh H=Help ):r
```

- 7** Enter **r** to refresh the display until the Diagnostic Status changes from TESTING to MESSAGE. At this point, the following panel is displayed.

```

                                Restore From Wrap Test                                Screen 1 of 1
LIC 287 - ESCON Channel Adapter, Slot 4
Operational Status  Diagnostic Status  Fault Status  Network Connection
  NOT CONFIGURED      MESSAGE          UNKNOWN      UNKNOWN

Do not remove this device while testing.

Remove the wrap plug on the ESCON adapter located in slot 4.

Reattach the fiber connection.

Select Back to see the results of the test.
Select ( B=Back R=Refresh H=Help ):b
    
```

- 8** Remove the wrap plug.
- 9** Reconnect the adapter's fiber optic cable.
- 10** Select **b** to view the results of the test. In this case, the system reports test completion with No Errors. If the test fails, you will receive a message directing further action.

```

                                Test Results                                Screen 1 of 1
LIC 287 - ESCON Channel Adapter, Slot 4
Operational Status  Diagnostic Status  Fault Status  Network Connection
  NOT CONFIGURED      INACTIVE          OK           UNKNOWN

The Test Completed with No Errors.

Select ( B=Back ): b
    
```

- 11** Select option **b** to return to the Test Controls Menu.

### Run the Light Test on the New Fiber Optic Cable

After you have run diagnostics on the new ESCON adapter and verified that it is functioning correctly, you can test that the fiber optic cable is connected properly and transmitting light to the adapter.

- 1 From the Test Controls Menu, select Run Interactive Test to display the Test Options panel.

```
Test Options Screen 1 of 1

LIC 287 - ESCON Channel Adapter, Slot 4

Operational Status Diagnostic Status Fault Status Network Connection
NOT CONFIGURED MESSAGE OK UNKNOWN

Do not remove this device while testing.
Select one of the following test options:
* < 1. Run all tests excluding external wrap test >
* < 2. Run all tests including external wrap test >
  Individual tests:
* < 3. PCI BUS >
* < 4. PROCESSOR >
* < 5. MEMORY >
* < 6. MEMORY PROT >
* < 7. TIMER >
* < 8. AIB >
* < 9. WRAP PLUG >
* <10. OPTICAL POWER >
* <11. LIGHT RECEPTION >

Select (1-11 or B=Back R=Refresh H=Help ):11
```

- 2 Enter 11 on the Test Options Panel to run the light reception test. At this point, the following panel appears.

```
Setup For Light Reception Test Screen 1 of 1

LIC 287 - ESCON Channel Adapter, Slot 4, Net # 0

Operational Status Diagnostic Status Fault Status Network Connection
NOT CONFIGURED TESTING OK UNKNOWN

First, be sure that you have successfully run the Wrap Plug Test on slot 4.

Then, remove the wrap plug from the ESCON adapter
(if still installed).

Connect the fiber for an operational ESCON channel to the adapter located in
slot 4.

Confirm that the correct fiber is installed.
< 1. Start test. >

Select (1 or B=Back R=Refresh H=Help ):1
```



- 3** Install the fiber, then enter **1** to start the test. Since this is a “long running test,” the Test Control Menu will be displayed again. Notice that the Diagnostic Status is TESTING. This indicates that the test is now running and will take about 20 seconds to complete.

```

                                     Screen 1 of 1
                               Test Control Menu

LIC 287 - ESCON Channel Adapter, Slot 4, Net # 0

Operational Status  Diagnostic Status  Fault Status  Network Connection
      NOT CONFIGURED      TESTING           OK             UNKNOWN

Do not remove this device while testing.

Select from the following:
  Disable Device
  Enable Device
  Run Default Test
  Run Interactive Test
  Loop Test - stop on first error
  Loop Test - Log all errors
  Stop Looping Test
  < 1. View Test History Log >
  < 2. View Hardware Error Log >

Select (1-2 or  B=Back R=Refresh H=Help ):r
    
```

- 4** Keep entering **r** until the Diagnostic Status changes from TESTING to MESSAGE. At this point, the following screen is displayed.

```

                                     Screen 1 of 1
                               Restore From Light Reception Test

LIC 287 - ESCON Channel Adapter, Slot 4, Net # 0

Operational Status  Diagnostic Status  Fault Status  Network Connection
      NOT CONFIGURED      MESSAGE           OK             UNKNOWN

Do not remove this device while testing.

Leave the fiber connected to the ESCON adapter located in slot 4
if it is the fiber intended for this adapter.

If it is not the fiber intended for this adapter,
connect the correct fiber now.

Select Back to see the results of the test.

Select (  B=Back R=Refresh H=Help ):b
    
```

- 5** Typically, you do not need to do anything here. If you are testing cables, this simply tells you that the test has completed and that you should ensure the right fiber is connected.

## Testing the ESCON Channel Adapter

### 6 Select **b** to see the results of the test.

```

                                     Test Results
                                     Screen 1 of 1

LIC 287 - ESCON Channel Adapter, Slot 4, Net # 0

Operational Status  Diagnostic Status  Fault Status  Network Connection
      NOT CONFIGURED      INACTIVE      OK            UNKNOWN

The Test Completed with No Errors.

Select ( B=Back ):
```

If the test completed with no errors, light was detected on the fiber optic cable.

```

                                     Test Results
                                     Screen 1 of 1

LIC 287 - ESCON Channel Adapter, Slot 4, Net # 0

Operational Status  Diagnostic Status  Fault Status  Network Connection
      NOT CONFIGURED      INACTIVE      NON-ISOLATED  UNKNOWN

No light is being detected on the ESCON adapter in slot 4. Ensure that the
ESCON fiber is connected to an ESCON director or an ESCON channel.

Select ( B=Back ):e
```

If light was not detected, an error message is displayed, indicating that the fiber and its connections need to be rechecked.

## Chapter 4. Configuring the ESCON Channel Adapter

This chapter describes how to configure the ESCON Channel Adapter and attached networks. It includes the following sections:

- “ESCON Channel Adapter Overview,” which describes ESCON support:
  - LCS (LAN Channel Station) over which you can run TCP/IP
  - LSA (Link Services Architecture) over which you can run hierarchical SNA, including DLSw, or APPN ISR
  - MPC+ (Multi-Path Channel) over which you can run APPN HPR
- “Configuring the ESCON Interface” on page 4-13
- “ESCON Configuration Commands” on page 4-14

### ESCON Channel Adapter Overview

The ESCON Channel Adapter provides the 2216 with access to SNA and TCP/IP host applications from LANs, WANs, and ATM over a duplex-to-duplex multimode fiber optic cable.

Figure 4-1 shows a 2216 connected to a VTAM host through an ESCON Channel Adapter. Each ESCON Channel Adapter provides up to 32 subchannels and up to 16 associated virtual network handlers that can support LAN Channel Station (LCS), Link Services Architecture (LSA), and Multi-Path Channel (MPC+) protocols. Each 2216 can contain up to four ESCON Channel Adapters and each ESCON Channel Adapter can provide connections to up to 16 hosts when used with an ESCON Director or access to up to 15 logical host images in EMIF-capable processors operating in logically partitioned mode.

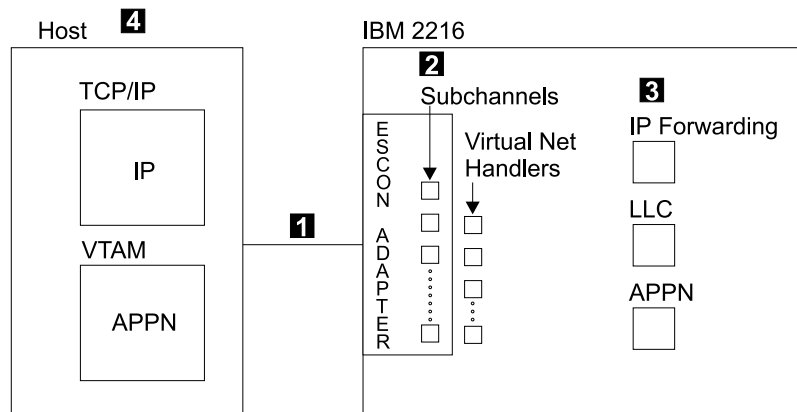

Figure 4-1. 2216 Connected to a Host through an ESCON Channel Adapter - Logical View

- 1** At the physical level, the ESCON Channel Adapter provides a flexible fiber optic connection to communication channels at the host processor.
- 2** At the logical level, the ESCON Channel Adapter provides up to 32 *subchannels* and up to 16 associated *virtual network handlers*.

Each virtual network handler supports one of the following protocols:

- LCS     LAN Channel Station
- LSA     Link Services Architecture
- MPC+   Multi-Path Channel+

## ESCON Channel Adapter Overview

For each LCS virtual network handler, you must define two subchannels, one for read and one for write; you can define up to 16 LCS virtual network handlers for each ESCON Channel Adapter.

For each LSA virtual network handler, you must define at least one subchannel up to a maximum of 32 subchannels. You can define up to 16 LSA virtual network handlers for each ESCON Channel Adapter.

For MPC+, you can define up to 32 subchannels. You must have at least one read subchannel and at least one write subchannel. You can define up to 16 MPC+ virtual network handlers for each ESCON Channel Adapter.

Each 2216 can contain up to 4 ESCON Channel Adapters and each ESCON Channel Adapter can provide connections to up to 16 hosts when used with an ESCON director or access up to 15 logical host images in EMIF-capable processors operating in logically partitioned mode.

### Notes:

1. You can configure LCS and LSA on the same ESCON Channel Adapter.
2. For migration purposes, MPC+ may be configured on the same ESCON Channel Adapter as LCS/LSA. This is not recommended as a long term solution. MPC+ combined with another type of virtual interface (LCS/LSA) on the same adapter could impact the performance benefits provided by the MPC+ interface.
- 3** The 2216 ESCON Channel Adapter provides services for IP Forwarding, Logical Link Control (LLC), and Advanced Peer-to-Peer Networking (APPN).
- 4** The virtual net handlers provide connections for transmitting and receiving packets of information for host applications as shown in Figure 4-2 on page 4-3 and Figure 4-3 on page 4-3.

Once the ESCON Channel Adapter is installed and configured for LCS, LSA, and MPC+, it can provide the functions listed in “ESCON Channel Adapter Functions” on page 1-1.

- Hierarchical SNA, including DLSw traffic, and APPN ISR traffic runs over LSA connections. (DLSw and APPN require LLC loopback.)
- TCP/IP traffic runs over LCS.
- APPN HPR traffic runs over MPC+

Figure 4-2 on page 4-3 shows the basic flow for an ESCON Channel Adapter with LCS and LSA configured, and Figure 4-3 on page 4-3 shows the basic flow for an ESCON Channel Adapter for which MPC+ is configured.

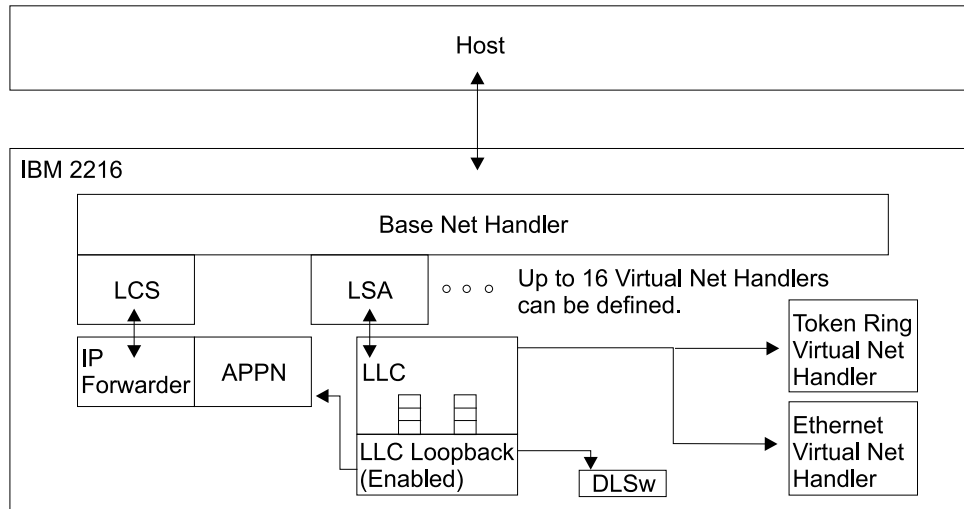

Figure 4-2. 2216 ESCON Virtual Net Handlers for LCS and LSA.

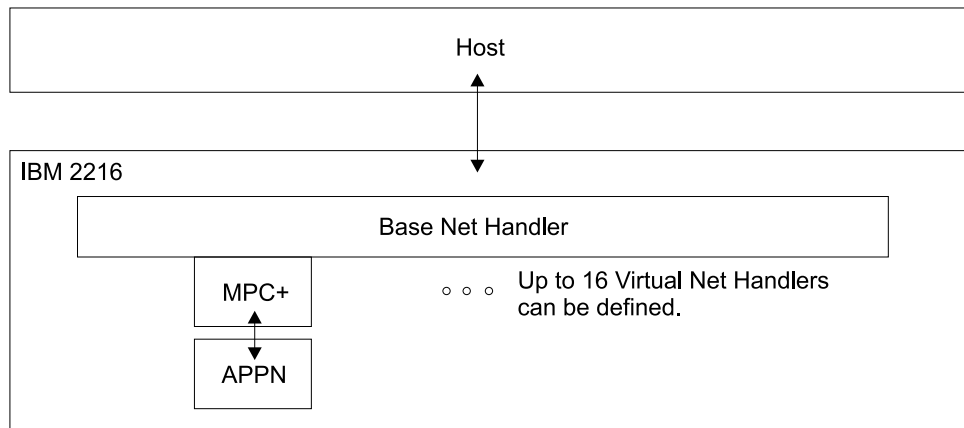

Figure 4-3. 2216 ESCON Virtual Net Handlers for MPC+.

## LAN Channel Station (LCS) Support

Figure 4-4 shows how TCP/IP data flows from the host, through LCS and other 2216 software components, and out to the LANs/WANs.

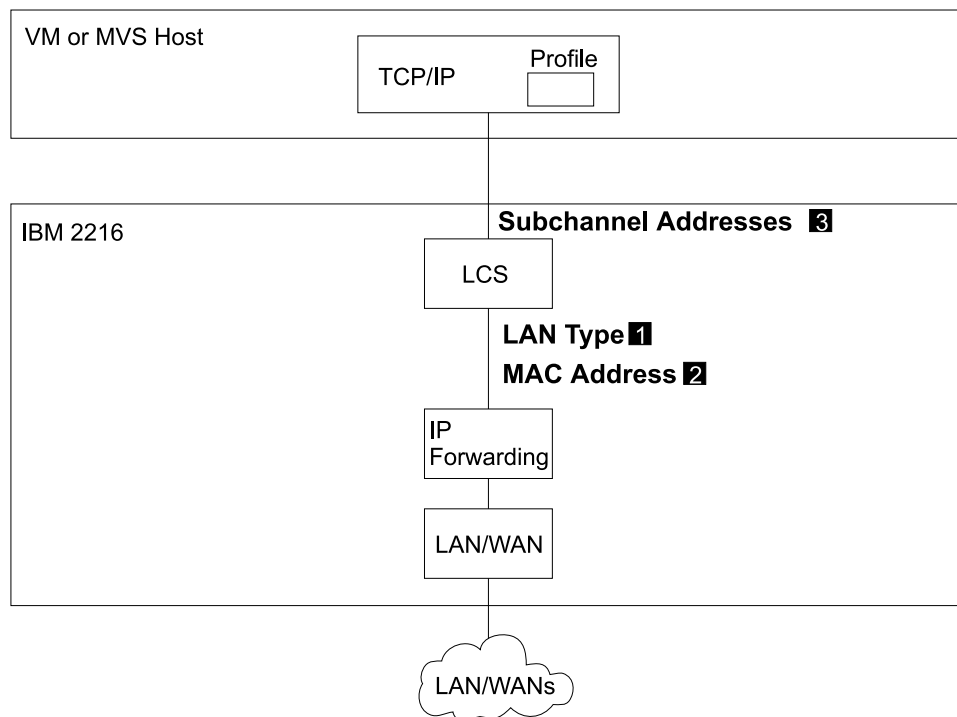

Figure 4-4. Configuring LAN Channel Station (LCS) Virtual Net Handlers. This figure shows LCS flow and highlights key parameters at the host and in the 2216.

### Configuring the 2216 for LCS

Three parameters are required to configure the 2216 for LCS as shown in Figure 4-4:

- 1 LAN type** Type of LAN connection, either Ethernet or Token Ring. This is the frame type that the host expects to send and receive.
- 2 MAC address** A unique MAC address to identify this virtual interface.

**Note:** If the LAN type is Ethernet, then the MAC address must be in canonical format.

- 3** Configure the subchannel pair used by this connection as described in “Configuring an LCS Subchannel” on page 4-16.

You must configure an IP address and mask. Refer to *IBM 2216 Software User's Guide*.

There is one optional parameter:

**maxdata** Maximum size of data handled by this virtual network

For information on the corresponding host definitions, see “Configuring the Host for TCP/IP” on page 1-31.

## Link Services Architecture (LSA) Support

Link Services Architecture (LSA) permits the VTAM host to communicate with the ESCON Channel Adapter in the 2216.

Figure 4-5 shows the four types of LSA connections:

- “Configuring an LSA Direct Connection at the 2216” on page 4-6
- “Configuring an LSA APPN Connection at the 2216” on page 4-7
- “Configuring an LSA DLSw Connection at the 2216” on page 4-9
- “Configuring an LSA DLSw Local Conversion at the 2216” on page 4-10

For information on the corresponding host definitions, see “VTAM Control Blocks Used to Configure LSA at the Host” on page 1-34.

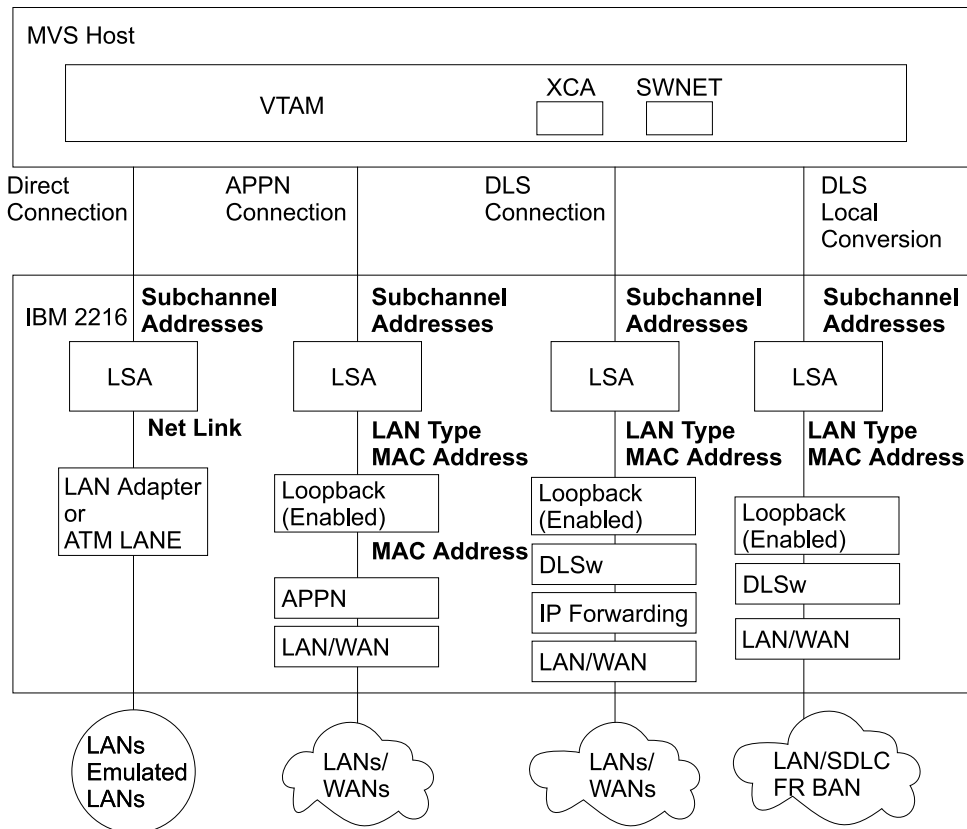

Figure 4-5. Configuring Link Services Architecture (LSA) Virtual Net Handlers

### Configuring an LSA Direct Connection at the 2216

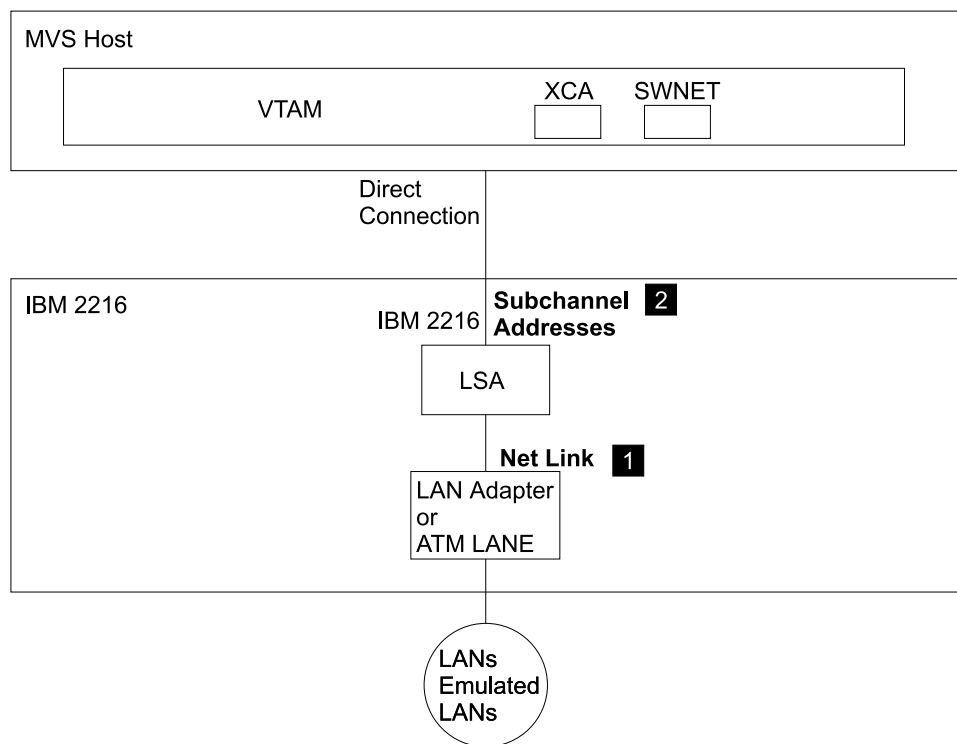

Figure 4-6. Configuring Virtual Net Handlers for LSA Direct Connection

Two parameters are required to configure the 2216 for a direct LSA connection as shown in Figure 4-6:

**1 Net Link** The network interface number of the LAN adapter to which the LSA network is linked. This is the interface used by the 2216 to transmit data to the host.

**2** Configure the subchannel or subchannels used by this connection as described in “Configuring an LSA Subchannel” on page 4-19.

There is one optional parameter:

**maxdata** Maximum size of data handled by this virtual network

**Note:** The LSA net will read its MAC address from the 2216 interface configured with the Net Link command.

For information on the corresponding host definitions, see “Configuring an LSA Direct Connection at the VTAM Host” on page 1-35.



### Configuring an LSA APPN Connection at the 2216

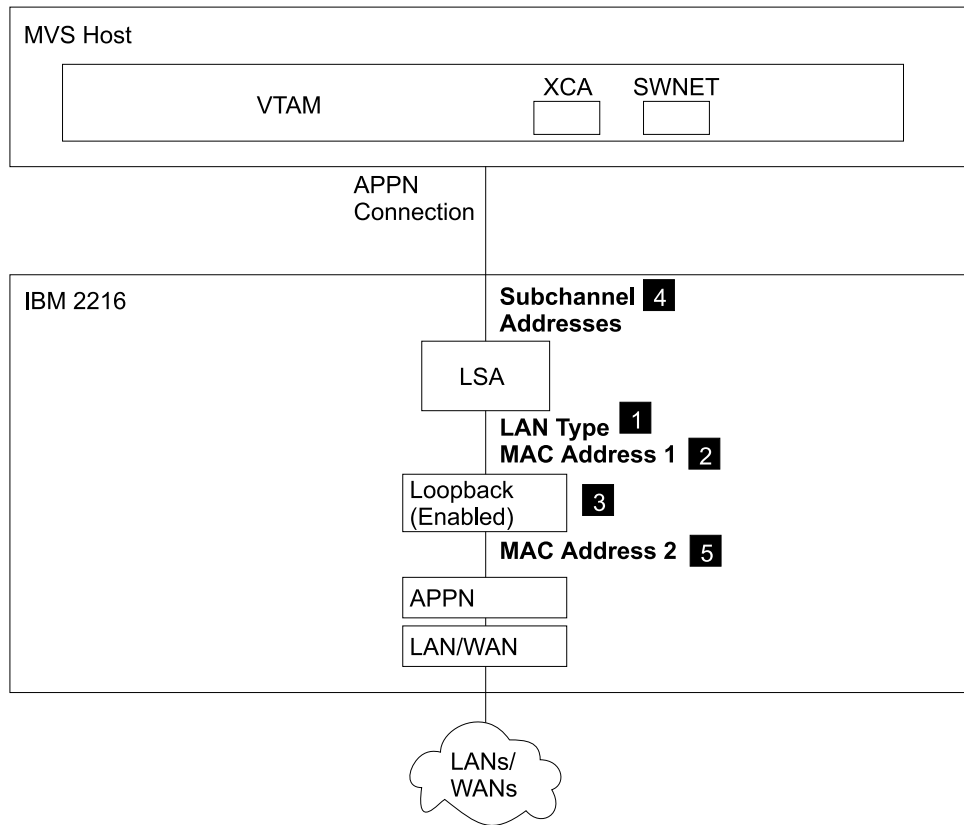

Figure 4-7. Configuring Virtual Net Handlers for LSA APPN Connection

Four parameters are required to configure the 2216 for an LSA APPN connection as shown in Figure 4-7:

- 1 LAN type**            LAN type, either Ethernet or Token Ring  
**Note:** You must configure the LAN type for both the LSA net and the Loopback net.
- 2 MAC Address 1**      A unique MAC address to identify the host (VTAM) end of the loopback connection.  
**Note:** If the LAN type is Ethernet, then the MAC address must be in canonical format.
- 3** Enable LSA loopback using the **enable** parameter.
- 4** Configure the subchannel or subchannels used by this connection as described in “Configuring an LSA Subchannel” on page 4-19.

There is one optional parameter:

**maxdata**                    Maximum size of data handled by this virtual network

Also, configure APPN to use the APPN loopback net. The APPN port must be configured on the APPN loopback net. To then configure an APPN link station over this APPN port, the destination mac address of the link station definition should be that of the LSA net.

## ESCON Channel Adapter Overview

Specify a LAN type (Token-Ring or Ethernet) using the LANtype command.

**5 MAC Address 2** A unique MAC address to identify the 2216 (APPN) end of the loopback connection.

**Note:** If the LAN type is Ethernet, then the MAC address must be in canonical format.

For information on the corresponding host definitions, see “Configuring an LSA APPN Connection at the VTAM host” on page 1-35.

### Configuring an LSA DLSw Connection at the 2216

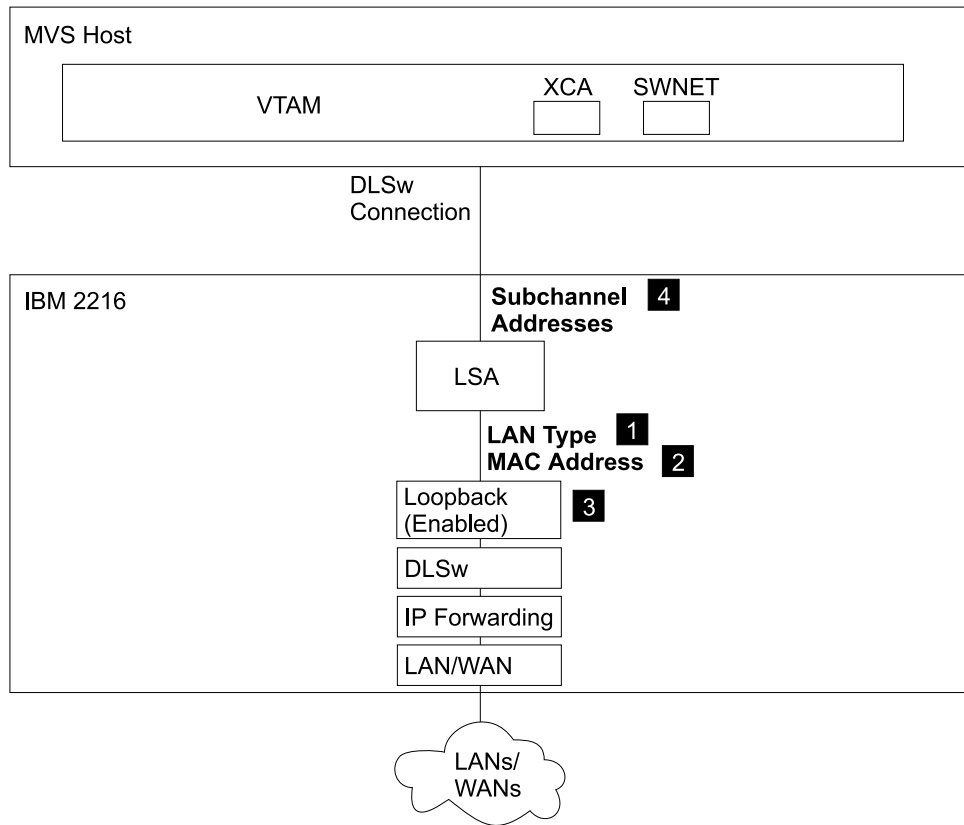

Figure 4-8. Configuring Virtual Net Handlers for LSA DLSw Connection

Four parameters are required to configure the 2216 for an LSA DLSw connection as shown in Figure 4-8:

- 1 LAN type** Type of LAN connection, either Ethernet or Token Ring. This is the frame type that the host expects to send and receive.
- 2 MAC Address** A unique MAC address to identify the host (VTAM) end of the loopback connection.

**Note:** If the LAN type is Ethernet, then the MAC address must be in canonical format.

- 3** Enable LSA loopback using the **enable** parameter.
- 4** Configure the subchannel or subchannels used by this connection as described in “Configuring an LSA Subchannel” on page 4-19.

There is one optional parameter:

**maxdata** Maximum size of data handled by this virtual network

For information on the corresponding host definitions, see “Configuring an LSA DLSw Connection at the VTAM Host” on page 1-36.

### Configuring an LSA DLSw Local Conversion at the 2216

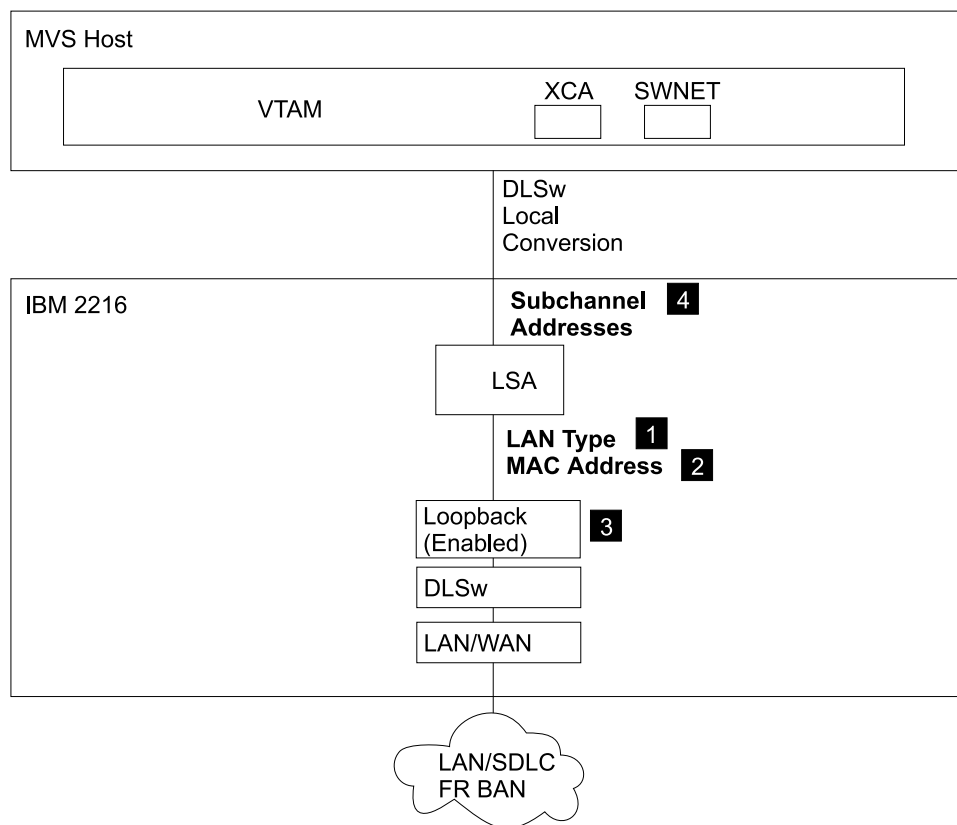

Figure 4-9. Configuring Virtual Net Handlers for LSA DLSw Local Conversion

Three parameters are required to configure the 2216 for LSA DLSw Local Conversion as shown in Figure 4-9:

- 1 LAN type** Type of LAN connection, either Ethernet or Token Ring. This is the frame type that the host expects to send and receive.
- 2 MAC Address** A unique MAC address to identify the host (VTAM) end of the loopback connection.

**Note:** If the LAN type is Ethernet, then the MAC address must be in canonical format.

- 3** Enable LSA loopback using the **enable** parameter.
- 4** Configure the subchannel or subchannels used by this connection as described in “Configuring an LSA Subchannel” on page 4-19.

There is one optional parameter:

**maxdata** Maximum size of data handled by this virtual network

## Multi-Path Channel+ (MPC+) Support

Figure 4-10 shows MPC+ flow and highlights key parameters at the host and in the 2216.

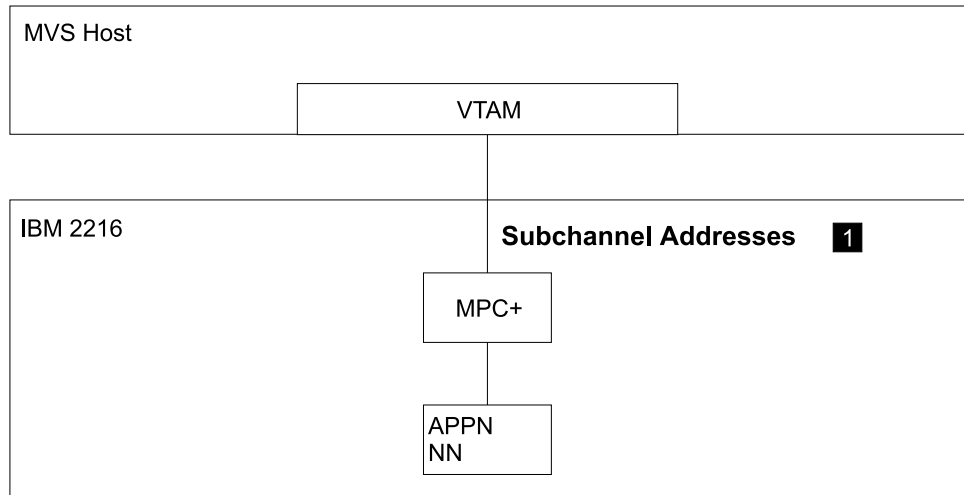

Figure 4-10. Configuring Virtual Net Handlers for Multi-Path Channel+ (MPC+)

### Configuring the 2216 for MPC+

Figure 4-10 shows the parameters required to configure MPC+.

**1** Configure subchannels for read and write connections to the host as described in “Configuring an MPC+ Subchannel” on page 4-22.

There are three optional parameters:

*reply timeout*

Timer for XID2/Disconnect timeout in milliseconds.

This is the amount of time that the MPC+ Group waits to hear from across the channel during XID2 and DISC exchanges before deciding that the other end of the channel is not answering and that this side should continue with the bring up or bring down of the MPC+ Group.

*sequencing interval timer*

Sequencing Interval Timer in milliseconds.

This timer is used to determine whether connection-oriented data is flowing smoothly across the connection on an MPC+ Group. The MPC+ control flows and the APPN activation/deactivation flows flow connection-oriented. Since these commands must have guaranteed delivery at the link level they flow connection-oriented and the Sequencing Interval timer is used to determine whether enough time has passed that checking of the delivery of connection-oriented traffic should be done.

**Note:** This value can be overwritten for each APPN PORT on an MPC+ Group. This is done during the APPN PORT configuration.

## ESCON Channel Adapter Overview

*maxdata* Maximum size of data handled by this virtual network handler.

With the following exceptions, APPN is configured over the MPC+ interface as it is over other interface types:

- On the APPN "add port" command, specify link type MPC+.
- On the APPN "add port" command, you may specify the MPC+ sequencing interval timer.

For information on the corresponding host definitions, see "Configuring the VTAM Host for MPC+" on page 1-39.

---

## Configuring the ESCON Interface

The following steps are required to configure the ESCON interface:

1. Access the ESCON interface as described in “Accessing the ESCON Interface.” This will cause the base ESCON interface to be defined.
2. Configure the virtual net handlers as described in:
  - “Configuring an LCS Virtual Interface” on page 4-15
  - “Configuring an LSA Virtual Interface” on page 4-17
  - “Configuring an MPC+ Virtual Interface” on page 4-21
3. Configure the subchannels:
  - “Configuring an LCS Subchannel” on page 4-16
  - “Configuring an LSA Subchannel” on page 4-19
  - “Configuring an MPC+ Subchannel” on page 4-22

Once the 2216 ESCON configuration is complete,

- Configure the protocols.
- Save the configuration.
- Reboot the 2216 to activate changes.

---

## Accessing the ESCON Interface

To access the ESCON interface:

1. At the OPCON prompt, enter **talk 6**. For example:

```
* talk 6
Config>
```

After you enter the **talk 6** command, the CONFIG prompt (Config>) displays on the console. If the prompt does not appear, press **Return** again.

2. Enter the **list devices** command to display the network interface numbers that are currently configured.
3. Record the interface numbers.
4. Create an ESCON interface by entering the **add device esc** command at the Config> prompt.

```
Config> add dev esc
Device Slot x(1-8) 1?
Adding ESCON Adapter device in slot 1 port 1 as interface x
```

**Note:** x is the assigned interface number.

**Note:** The 2216 has eight slots, numbered 1 to 8.

5. Enter the **network** command and the number of the ESCON interface you want to configure. For example:

```
Config> network 0
ESCON Config>
```

The ESCON configuration prompt (ESCON Config>), is displayed.

6. Configure the ESCON virtual net handlers and associated subchannels using the commands in Table 4-1 on page 4-14.

---

## ESCON Configuration Commands

The following commands can be entered at the ESCON configuration prompt (ESCON Config>):

| <i>Table 4-1. ESCON Interface Configuration Commands</i> |                                                                                                                                                                                                                                                                                                                                                                                         |
|----------------------------------------------------------|-----------------------------------------------------------------------------------------------------------------------------------------------------------------------------------------------------------------------------------------------------------------------------------------------------------------------------------------------------------------------------------------|
| <b>Command</b>                                           | <b>Description</b>                                                                                                                                                                                                                                                                                                                                                                      |
| <b>? (Help)</b>                                          | Lists all of the ESCON interface configuration commands or lists the options associated with specific commands.                                                                                                                                                                                                                                                                         |
| <b>add</b>                                               | Adds a virtual net handler for one of the base protocols or adds APPN loopback : <ul style="list-style-type: none"><li>• LCS - LAN Channel Station Support</li><li>• LSA - Link Services Architecture</li><li>• MPC+ - Multi-Path Channel+</li><li>• APPN loopback</li></ul> Each protocol provides a unique set of parameters which can be used to configure the virtual net handlers. |
| <b>list</b>                                              | Lists the ESCON configuration and optionally lists subchannels.                                                                                                                                                                                                                                                                                                                         |
| <b>exit</b>                                              | Exits the ESCON configuration process or returns to the previous prompt level.                                                                                                                                                                                                                                                                                                          |

### ? (Help)

Use the ? command to list the configuration commands that are available from the command prompt level. You can also enter ? after a subcommand to list its options.

#### Syntax ?

#### Example:

```
ESCON Config> ?
ADD
MODify
DElete
LIst
Exit
```

**Note:** Valid command abbreviations are shown in uppercase letters. For example, LIst means that you can enter LI for the **list** command.

### Add

Use the **add** command to add virtual network handlers for LCS, LSA, and MPC+, and to enable loopback for APPN.

**Syntax:** add lcs  
lsa  
mpc  
appn loopback



## Configuring an LCS Virtual Interface

### add lcs

Under add lcs, the following second-level parameters can be entered:

*lan type*  
*mac address*  
*subchannels*  
*maxdata*

Use the **add lcs** command to add an LCS virtual interface and get to the ESCON Add Virtual> prompt from which you can enter other interface and subchannel parameters.

**Note:** Although LCS requires two subchannels, it is only necessary to specify one subchannel. An adjacent subchannel will be chosen such that the two subchannels will form a sequential pair with the write subchannel (device address is even) before the read subchannel (device address is odd).

See “LAN Channel Station (LCS) Support” on page 4-4 for a description of flow and key parameters.

#### Example: Adding an LCS interface

```
ESCON Config>add lcs
ESCON Add Virtual>
```

*LAN Type*      LAN type, either Ethernet or Token Ring

#### Example: Specifying LAN Type for an LCS interface

```
ESCON Add Virtual>lan
Please select one of the following LAN types:
  E Ethernet
  T Token Ring
LCS LAN Type: [E]?
```

*MAC Address*      MAC Address of the virtual net handler

#### Example: Specifying MAC Address for an LCS interface

```
ESCON Add Virtual>mac
MAC address in 00:00:00:00:00:00 form [000000000000]? 40:00:22:16:00:01
```

*maxdata*      Maximum size of data handled by this virtual network handler.

**Valid Values:** 516 to 17749 for Token Ring, 1500 for Ethernet

**Default:** 2052 for token ring, 1500 for Ethernet

#### Example: Specifying maxdata for an LCS interface

```
ESCON Add Virtual>max 2052
```

### Configuring an LCS Subchannel

#### subchannels

A subcommand from which you can add, modify, delete, or list subchannels.

Under add lcs subchannels, the following third-level parameters can be entered:

*add*  
*modify*  
*delete*  
*list*

**add** Adds a subchannel pair and displays the ESCON Config LCS Subchannel> prompt from which you can add Device Address, LPAR number, Link Address, and CU Logical Address.

**Note:** You must add or configure one subchannel for an LCS virtual interface. Although LCS requires two subchannels, it is only necessary to specify one subchannel. An adjacent subchannel will be chosen such that the two subchannels will form a sequential pair with the write subchannel (device address is even) before the read subchannel (device address is odd).

#### Device Address

The unit address transmitted on the channel path to select a 2216 device. It is also referred to as subchannel number in S/370 I/O architecture. It is a two-digit hexadecimal value that may range from 00-FF. This value is defined in the host IOCP by the UNITADD statement on the CNTLUNIT macro instruction for the real device.

**Valid Values:** X'00' to X'FF'

**Default:** None

#### LPAR number

Logical partition number. This allows multiple logical host partitions, LPARs, to share one ESCON fiber.

This value is defined in the host Input/Output Configuration Program (IOCP) by the RESOURCE macro instruction.

If the host is not using EMIF, use the default of 0 for the LPAR number.

**Valid Values:** X'0' - X'F'

**Default:** X'0'

#### Link Address

If one ESCD is in the communication path, the link address is the ESCON Director (ESCD) port number that is attached to the host.

If two ESCDs are in the path, it is the host-side port number of the ESCD defined with the dynamic connection.

When no ESCD is in the communication path, this value must be set to X'01'.

**Valid Values:** X'01' - X'FE'

**Default:** X'01'

#### CU Logical Address

The Control Unit address defined in the host for the 2216. This value is defined in the host Input/Output Configuration Program

(IOCP) by the CUADD statement on the CNTLUNIT macro instruction.

The Control Unit Address must be unique for each logical partition defined on the same host.

**Valid Values:** X'0' - X'F'

**Default:** X'0'

Enter **exit** to return to the ESCON Add Virtual> prompt.

### Example: Adding a subchannel for an LCS interface

```
ESCON Add Virtual>sub add
```

Please add or configure one subchannel for an LCS virtual interface. Although LCS requires two subchannels, it is only necessary to specify one subchannel. An adjacent subchannel will be chosen such that the two subchannels will form a sequential pair with the write subchannel (device address is even) before the read subchannel (device address is odd).

```
ESCON Config LCS Subchannel>d 4
```

```
ESCON Config LCS Subchannel>e
```

- mod** Modifies a configured LCS subchannel pair. It lists the configuration for the configured LCS subchannels and allows you to modify one of them by specifying the “sub” number from the list. Once you have selected the subchannel, you can change the device address, LPAR number, Link Address, and CU Logical Address as described in “Configuring an LCS Subchannel” on page 4-16.
- delete** Deletes a configured LCS subchannel. It lists the configuration for the configured LCS subchannels and allows you to delete one of them by specifying the “sub” number from the list.
- list** Lists information for the LCS subchannels.

### Example: Listing subchannels for an LCS interface

```
ESCON Add Virtual>sub lis
```

```
Read Subchannels:
```

```
Sub 0 Device address : 5 LPAR number : 0
      Link address : 1 CU Logical Address : 0
```

```
Write Subchannels:
```

```
Sub 1 Device address : 4 LPAR number : 0
      Link address : 1 CU Logical Address : 0
```

- exit** Returns to the previous prompt.

## Configuring an LSA Virtual Interface

### add lsa

Under add lsa, the following second-level parameters can be entered:

*enable*  
*disable*  
*maxdata*  
*net link*  
*lantype*  
*subchannels*

Use the **add lsa** command to add an LSA virtual interface and get to the ESCON Add Virtual> prompt from which you can enter other interface and subchannel parameters.

## ESCON Configuration Commands

There are four types of LSA connections, as shown in Figure 4-5 on page 4-5. They are:

- “Configuring an LSA Direct Connection at the 2216” on page 4-6
- “Configuring an LSA APPN Connection at the 2216” on page 4-7
- “Configuring an LSA DLSw Connection at the 2216” on page 4-9
- “Configuring an LSA DLSw Local Conversion at the 2216” on page 4-10

The example shows adding two LSA interfaces. The first one uses loopback and the second one is a direct connection.

### Example 1: Adding an LSA interface with loopback

```
ESCON Config>add lsa
ESCON Add Virtual>enable
Enabling loopback through network 2.
Please set the MAC address using the "MAC" command
ESCON Add Virtual>mac 40:00:00:00:22:16
ESCON Add Virtual>lan
Please select one of the following LAN types:
  E Ethernet
  T Token Ring
LSA LAN Type: [E]? e
ESCON Add Virtual>sub add
ESCON Add LSA Subchannel>link c5
ESCON Add LSA Subchannel>d 8
ESCON Add LSA Subchannel>e
ESCON Add Virtual>e
ESCON Config>list all
Net: 2 Protocol: LSA LAN type: LSA Ethernet LAN number: 0
      Maxdata: 1500
      Loopback is enabled.
      MAC address: 400000002216
      Sub 0 Dev addr: 8 LPAR: 0 Link addr: C5 CU addr: 0
```

### Example 2: Adding an LSA interface with direct connection

```
ESCON Config>add lsa
ESCON Add Virtual>net 0
ESCON Add Virtual>sub add
ESCON Add LSA Subchannel>link c5
ESCON Add LSA Subchannel>d 9
ESCON Add LSA Subchannel>e
ESCON Add Virtual>e
ESCON Config>list all
Net: 2 Protocol: LSA LAN type: LSA Ethernet LAN number: 0
      Maxdata: 1500
      Loopback is enabled.
      MAC address: 400000002216
      Sub 0 Dev addr: 8 LPAR: 0 Link addr: C5 CU addr: 0

Net: 3 Protocol: LSA LAN type: Token Ring LAN number: 0
      Maxdata: 2052
      Loopback is not enabled.
      MAC address: Obtained from net 0
      Sub 0 Dev addr: 9 LPAR: 0 Link addr: C5 CU addr: 0
```

ESCON Config>

#### *enable OR disable*

Enables or disables loopback on an LSA interface.

**Note:** Only *one* of these parameters can be entered, depending on the state of the loopback function. If the loopback is disabled, you can enable it; if it is enabled, you can disable it.

**Valid Values:** enable or disable

**Default:** disable

**Example:** Enabling loopback on LSA interface

```
ESCON Config>add 1sa
ESCON Add Virtual>en
Enabling loopback through network 5.
Please set the MAC address using the "MAC" command
```

*LAN Type* LAN type, either Ethernet or Token Ring

**Example:**

```
ESCON Config>add 1sa
ESCON Add Virtual>1ant
Please select one of the following LAN types:
  E Ethernet
  T Token Ring
LSA LAN Type: [E]? e
```

*maxdata* Maximum size of data handled by this virtual network handler.

**Valid Values:** 516 to 17749 for Token Ring, 1500 for Ethernet

**Default:** 2052 for Token Ring, 1500 for Ethernet

**Example:**

```
ESCON Config>add 1sa
ESCON Add Virtual>max 2052
```

*Net Link* This parameter is available only when loopback is disabled. It is used to indicate the LAN adapter over which this LSA net will communicate. The LAN adapter must have been previously configured and can only be Token-Ring or Ethernet (including emulated LANs).

**Example:**

```
ESCON Config>add 1sa
ESCON Add Virtual>net 0
```

*MAC Address* .A unique MAC address to identify this virtual interface. This parameter is available only when loopback is enabled. It is the MAC address of the LSA/VTAM side of the loopback connection. The MAC address of the APPN side of the loopback connection is specified using ADD APPN.

## Configuring an LSA Subchannel

### subchannels

A subcommand from which you can add, modify, delete, or list subchannels.

Under add lsa subchannels, the following third-level parameters can be entered:

```
add
modify
delete
list
```

**add** Adds a subchannel and displays the ESCON Add LSA Subchannel1> prompt from which you can add:

## ESCON Configuration Commands

### Device Address

The unit address transmitted on the channel path to select a 2216 device. It is also referred to as subchannel number in S/370 I/O architecture. It is a two-digit hexadecimal value that may range from 00-FF. This value is defined in the host IOCP by the UNITADD statement on the CNTLUNIT macro instruction for the real device.

**Valid Values:** X'00' to X'FF'

**Default:** None

### LPAR number

Logical partition number. This allows the host multiple logical partitions (LPARs) to share one ESCON channel.

This value is defined in the host Input/Output Configuration Program (IOCP) by the RESOURCE macro instruction.

If the host is not using EMIF, use the default of 0 for the LPAR number.

**Valid Values:** X'0' - X'F'

**Default:** X'0'

### Link Address

If one ESCD is in the communication path, the link address is the ESCON Director (ESCD) port number that is attached to the host. If two ESCDs are in the path, it is the host-side port number of the ESCD defined with the dynamic connection.

When no ESCD is in the communication path, this value must be set to X'01'.

**Valid Values:** X'01' - X'FE'

**Default:** X'01'

### CU Logical Address

The Control Unit address defined in the host for the 2216. This value is defined in the host Input/Output Configuration Program (IOCP) by the CUADD statement on the CNTLUNIT macro instruction. The Control Unit Address must be unique for each LPAR defined on the same host.

**Valid Values:** X'0' - X'F'

**Default:** X'0'

Enter **exit** to return to the ESCON Add Virtual> prompt.

**Example:** Adding a subchannel for an LSA interface

```
ESCON Add Virtual>sub add
ESCON Add LSA Subchannel>link f7
ESCON Add LSA Subchannel>device 0
ESCON Add LSA Subchannel>cu 0
ESCON Add LSA Subchannel>lpar 0
ESCON Add LSA Subchannel>exit
```

**mod** Modifies a configured LSA subchannel. It lists the configuration for the configured LSA subchannels and allows you to modify one of them by specifying the “sub” number from the list. Once you have selected the subchannel, you can change the device address, LPAR number, Link Address, and CU Logical Address as described in “Configuring an LSA Subchannel” on page 4-19.

- delete** Deletes a configured LSA subchannel. It lists the configuration for the configured LSA subchannels and allows you to delete one of them by specifying the “sub” number from the list.
- list** Lists information for the LSA subchannels.

**Example:** Listing subchannels for an LSA interface

```
ESCON Config Virtual>sub list
Sub 0 Device address : 42 LPAR number : 0
      Link address  : C5 CU Logical Address : 0
Sub 1 Device address : 43 LPAR number : 0
      Link address  : C5 CU Logical Address : 0
Sub 2 Device address : 44 LPAR number : 0
      Link address  : C5 CU Logical Address : 0
```

- exit** Returns to the previous prompt.

### Configuring an MPC+ Virtual Interface

#### add mpc

Under add mpc, the following second-level parameters can be entered:

*reply timeout*  
*sequencing interval timer*  
*maxdata*  
*subchannels*

Use the **add mpc** command to add a MPC+ virtual interface and get to the ESCON Add Virtual> prompt from which you can enter other interface and subchannel parameters.

See “Configuring the 2216 for MPC+” on page 4-11 for a description of flow and key parameters.

**Example:** Adding an MPC+ interface

```
ESCON Config>add mpc
ESCON Add Virtual>
```

*reply timeout*

Timer for XID2/Disconnect timeout in milliseconds.

**Valid Values:** 1 to 50 000

**Default:** 45 000

*sequencing interval timer*

Sequencing Interval Timer in milliseconds.

**Valid Values:** 1 to 50 000

**Default:** 3000

*maxdata*

Maximum size of data handled by this virtual network handler.

**Valid Values:** 512 to 32 768

**Default:** 2048

### Configuring an MPC+ Subchannel

#### subchannels

A subcommand from which you can add, modify, delete, or list subchannels.

Under add mpc subchannels, the following third-level parameters can be entered:

*addr* (add a read subchannel)  
*addw* (add a write subchannel)  
*modify*  
*delete*  
*list*

**Note:** A subchannel defined as a read subchannel to VTAM is a write subchannel to the 2216 and a subchannel defined as a write subchannel to VTAM is a read subchannel to the 2216.

**addr** Adds a read subchannel and displays the ESCON Add MPC+ Read Subchannel> prompt from which you can add:

#### Device Address

The unit address transmitted on the channel path to select a 2216 device. It is also referred to as subchannel number in S/370 I/O architecture. It is a two-digit hexadecimal value that may range from 00-FF. This value is defined in the host IOCP by the UNITADD statement on the CNTLUNIT macro instruction for the real device.

**Valid Values:** X'00' to X'FF'

**Default:** None

#### LPAR number

Logical partition number. This allows the host multiple logical partitions (LPARs) to share one ESCON channel.

This value is defined in the host Input/Output Configuration Program (IOCP) by the RESOURCE macro instruction.

If the host is not using EMIF, use the default of 0 for the logical partition number.

**Valid Values:** X'0' - X'F'

**Default:** X'0'

#### Link Address

If one ESCD is in the communication path, the link address is the ESCON Director (ESCD) port number that is attached to the host.

If two ESCDs are in the path, it is the host-side port number of the ESCD defined with the dynamic connection.

When no ESCD is in the communication path, this value must be set to X'01'.

**Valid Values:** X'01' - X'FE'

**Default:** X'01'

#### CU Logical Address

The Control Unit address defined in the host for the 2216. This value is defined in the host Input/Output Configuration Program (IOCP) by the CUADD statement on the CNTLUNIT macro instruction.



The Control Unit Address must be unique for each LPAR defined on the same host.

**Valid Values:** X'0' - X'F'

**Default:** X'0'

Enter **exit** to return to the ESCON Add Virtual> prompt.

**Example:** Adding read subchannels for an MPC+ interface

```
ESCON Add Virtual>sub addr
ESCON Add MPC+ Read Subchannel>d 8
ESCON Add MPC+ Read Subchannel>e
ESCON Add Virtual>sub addr
ESCON Add MPC+ Read Subchannel>d 9
ESCON Add MPC+ Read Subchannel>e
```

**addw** Adds a write subchannel and displays the ESCON Add MPC+ Write Subchannel> prompt from which you can add:

Device Address

The unit address transmitted on the channel path to select a 2216 device. It is also referred to as subchannel number in S/370 I/O architecture. It is a two-digit hexadecimal value that may range from 00-FF. This value is defined in the host IOCP by the UNITADD statement on the CNTLUNIT macro instruction for the real device.

**Valid Values:** X'00' to X'FF'

**Default:** None

LPAR number

Logical partition number. This allows multiple logical host partitions, LPARs, to share one ESCON fiber.

This value is defined in the host Input/Output Configuration Program (IOCP) by the RESOURCE macro instruction.

If the host is not using EMIF, use the default of 0 for the LPAR number.

**Valid Values:** X'0' - X'F'

**Default:** X'0'

Link Address

If one ESCD is in the communication path, the link address is the ESCON Director (ESCD) port number that is attached to the host.

If two ESCDs are in the path, it is the host-side port number of the ESCD defined with the dynamic connection.

When no ESCD is in the communication path, this value must be set to X'01'.

**Valid Values:** X'01' - X'FE'

**Default:** X'01'

CU Logical Address

The Control Unit address defined in the host for the 2216. This value is defined in the host Input/Output Configuration Program (IOCP) by the CUADD statement on the CNTLUNIT macro instruction.

The Control Unit Address must be unique for each logical partition defined on the same host.

**Valid Values:** X'0' - X'F'

**Default:** X'0'

**Example:** Adding write subchannels for an MPC+ interface

```
ESCON Add Virtual>sub addw
ESCON Add MPC+ Write Subchannel>d 10
ESCON Add MPC+ Write Subchannel>e
ESCON Add Virtual>sub addw
ESCON Add MPC+ Write Subchannel>d 11
ESCON Add MPC+ Write Subchannel>e
```

- mod** Modifies a configured MPC+ subchannel. It lists the configuration for the configured MPC+ subchannels and allows you to modify one of them by specifying the “sub” number from the list. Once you have selected the subchannel, you can change the device address, LPAR number, Link Address, and CU Logical Address as described in “Configuring an MPC+ Subchannel” on page 4-22.
- delete** Deletes a configured MPC+ subchannel. It lists the configuration for the configured MPC+ subchannels and allows you to delete one of them by specifying the “sub” number from the list.
- list** Lists information for the MPC+ subchannels.

**Example:** Listing subchannels for an MPC+ interface

```
ESCON Add Virtual>sub lis
Read Subchannels:
Sub 0 Device address : 8 LPAR number : 0
Link address : 1 CU Logical Address : 0
Sub 1 Device address : 9 LPAR number : 0
Link address : 1 CU Logical Address : 0
Write Subchannels:
Sub 2 Device address : 10 LPAR number : 0
Link address : 1 CU Logical Address : 0
Sub 3 Device address : 11 LPAR number : 0
Link address : 1 CU Logical Address : 0
```

- exit** Returns to the ESCON Add Virtual prompt.

```
ESCON Add Virtual>e
```

Once you have returned to the ESCON Config> prompt, you can list the entire MPC+ configuration as shown in the following example:

**Example:** Listing the MPC+ configuration

```
ESCON Config>list all
Net: 1 Protocol: MPC+ LAN type: MPC+ LAN number: 0
Maxdata: 2048
Reply T0: 45000 Sequencing Interval Timer: 3000
Read Subchannels:
Sub 0 Dev addr: 40 LPAR: 0 Link addr: F5 CU addr: 0
Write Subchannels:
Sub 1 Dev addr: 41 LPAR: 0 Link addr: F5 CU addr: 0

Net: 2 Protocol: MPC+ LAN type: MPC+ LAN number: 1
Maxdata: 2048
Reply T0: 45000 Sequencing Interval Timer: 3000
Read Subchannels:
Sub 0 Dev addr: 42 LPAR: 0 Link addr: F5 CU addr: 0
Write Subchannels:
Sub 1 Dev addr: 43 LPAR: 0 Link addr: F5 CU addr: 0

Net: 3 Protocol: MPC+ LAN type: MPC+ LAN number: 2
Maxdata: 2048
Reply T0: 45000 Sequencing Interval Timer: 3000
```

```

Read Subchannels:
Sub 0 Dev addr: 44 LPAR: 0 Link addr: F5 CU addr: 0
Write Subchannels:
Sub 1 Dev addr: 45 LPAR: 0 Link addr: F5 CU addr: 0

ESCON Config>mod 3
ESCON Config Virtual>?
REply timeout
SEQuencing int timer
MAXdata
SUBchannels
Exit
ESCON Config Virtual>rep 3100
ESCON Config Virtual>exit
ESCON Config>list all
Net: 1 Protocol: MPC+ LAN type: MPC+ LAN number: 0
Maxdata: 2048
Reply T0: 45000 Sequencing Interval Timer: 3000
Read Subchannels:
Sub 0 Dev addr: 40 LPAR: 0 Link addr: F5 CU addr: 0
Write Subchannels:
Sub 1 Dev addr: 41 LPAR: 0 Link addr: F5 CU addr: 0

Net: 2 Protocol: MPC+ LAN type: MPC+ LAN number: 1
Maxdata: 2048
Reply T0: 45000 Sequencing Interval Timer: 3000
Read Subchannels:
Sub 0 Dev addr: 42 LPAR: 0 Link addr: F5 CU addr: 0
Write Subchannels:
Sub 1 Dev addr: 43 LPAR: 0 Link addr: F5 CU addr: 0

Net: 3 Protocol: MPC+ LAN type: MPC+ LAN number: 2
Maxdata: 2048
Reply T0: 3100 Sequencing Interval Timer: 3000
Read Subchannels:
Sub 0 Dev addr: 44 LPAR: 0 Link addr: F5 CU addr: 0
Write Subchannels:
Sub 1 Dev addr: 45 LPAR: 0 Link addr: F5 CU addr: 0

ESCON Config>

```

## Configuring APPN Loopback

### add appn loopback

Under add appn, the following second-level parameters can be entered:

*lantype*  
*mac address*

Use the **add appn** command to add APPN loopback.

**Note:** APPN loopback cannot be added unless loopback has been enabled on an LSA virtual net as described in “Configuring an LSA Virtual Interface” on page 4-17.

*LAN Type* Ethernet or Token Ring

*MAC Address* A unique MAC address to identify the APPN side of the loopback connection in the 2216. This address must be different from the MAC address given to the host (VTAM) side of the loopback connection when configuring the LSA interface.

## ESCON Configuration Commands

### Example: Adding APPN loopback

```
ESCON Config>add appn
ESCON Add Virtual>
ESCON Add Virtual>lan
Please select one of the following LAN types:
  E Ethernet
  T Token Ring
APPN LAN Type: [T]?
ESCON Add Virtual>mac
MAC address in 00:00:00:00:00:00 form [000000000000]? 40:00:22:16:00:09
ESCON Add Virtual>e
ESCON Config>li all
Net: 9 Protocol: APPN Loopback LAN type: Token-Ring/802.5
      APPN loopback MAC address: 400022160009

Net: 5 Protocol: LSA LAN type: Token Ring LAN number: 0
      Maxdata: 2052
      Loopback is enabled.
      MAC address: 400022160005
      Sub 0 Dev addr: 0 LPAR: 0 Link addr: 1 CU num: 0

Net: 6 Protocol: LSA LAN type: Token Ring LAN number: 1
      Maxdata: 2052
      Loopback is not enabled.
      MAC address: Obtained from net 3
      Sub 0 Dev addr: 1 LPAR: 0 Link addr: 1 CU num: 0

Net: 7 Protocol: LCS LAN type: LCS Ethernet 802.3 LAN number: 0
      Maxdata: 1500
      MAC address: 400022160007
      Read Subchannels:
      Sub 0 Dev addr: 5 LPAR: 0 Link addr: 1 CU num: 0
      Write Subchannels:
      Sub 1 Dev addr: 4 LPAR: 0 Link addr: 1 CU num: 0
ESCON Config>e
```

### Notes:

1. The APPN port would be configured on net 9 of the example.
2. Any APPN link station to VTAM over this APPN port would be configured to use the mac address of one of the LSA nets that have the same LAN type of the APPN loopback net.

## Delete

Use the **delete** command to delete an interface on the ESCON adapter. If you know the interface number you wish to delete, you can specify it; otherwise, if you do not enter an interface number, the configuration is listed and you will be prompted to enter an interface number.

**Syntax:** delete interface\_number  
(no parameter)

### interface\_number

Deletes the configuration for the specified interface number.

### Example: Deleting a specified interface

```
ESCON Config>del 1
Are you sure?(Yes or [No]): y
```

### (no parameters)

Lists the configured interfaces for the ESCON adapter and prompts you for the interface number you wish to delete.

## Example: Deleting an interface (no parameters given)

```

ESCON Config>del
Net: 1 Protocol: MPC+ LAN type: MPC+ LAN number: 0
      Maxdata: 2048
      Reply TO: 45000 Sequencing Interval Timer: 3000
Net: 2 Protocol: MPC+ LAN type: MPC+ LAN number: 1
      Maxdata: 2048
      Reply TO: 45000 Sequencing Interval Timer: 3000
Net: 3 Protocol: MPC+ LAN type: MPC+ LAN number: 2
      Maxdata: 2048
      Reply TO: 45000 Sequencing Interval Timer: 3000
Virtual net number to delete: [1]? 3
Are you sure?(Yes or [No]): y

```

## Mod

Use the **mod** command to modify a configured interface on the ESCON adapter. If you know the interface number you wish to modify, you can specify it; otherwise, if you do not enter an interface number, the configuration is listed and you will be prompted to enter an interface number.

**Syntax:** modify interface\_number  
(no parameters)

### interface\_number

Modifies the configuration for the specified interface number.

### (no parameters)

Lists the configured interfaces for the ESCON adapter and prompts you for the interface number you wish to modify.

```

ESCON Config> mod
Net: 1 Protocol: MPC+ LAN type: MPC+ LAN number: 0
      Maxdata: 2048
      Reply TO: 45000 Sequencing Interval Timer: 3000
Net: 2 Protocol: MPC+ LAN type: MPC+ LAN number: 1
      Maxdata: 2048
      Reply TO: 45000 Sequencing Interval Timer: 3000
Virtual net number to configure: [1]? 2
ESCON Config Virtual> ?
REply timeout
SEQuencing int timer
MAXdata
SUBchannels
Exit
ESCON Config Virtual>re
Reply Time Out (range 1-50000 milliseconds): [45000]? 30003
ESCON Config Virtual>sub list
Read Subchannels:
Sub 0 Device address : 7 LPAR number : 0
      Link address : F4 CU Logical Address : 0
Write Subchannels:
Sub 1 Device address : 6 LPAR number : 0
      Link address : F4 CU Logical Address : 0
ESCON Config Virtual>sub addr
ESCON Add MPC+ Read Subchannel> ?
LINK address (ESCD Port)
LPAR number
CU logical address
Device address
Exit
ESCON Add MPC+ Read Subchannel>d 5
ESCON Add MPC+ Read Subchannel>? e
ESCON Config Virtual>sub list
Read Subchannels:
Sub 0 Device address : 7 LPAR number : 0
      Link address : F4 CU Logical Address : 0

```

## ESCON Configuration Commands

```
Sub 1 Device address : 5 LPAR number : 0
      Link address  : F4 CU Logical Address : 0
Write Subchannels:
Sub 2 Device address : 6 LPAR number : 0
      Link address  : F4 CU Logical Address : 0
ESCON Config Virtual>sub ?
ADDRead subchannel
ADDWrite subchannel
MODify subchannel
DELeTe subchannel
LIst subchannels
ESCON Config Virtual>sub del
Read Subchannels:
Sub 0 Device address : 7 LPAR number : 0
      Link address  : F4 CU Logical Address : 0
Sub 1 Device address : 5 LPAR number : 0
      Link address  : F4 CU Logical Address : 0
Write Subchannels:
Sub 2 Device address : 6 LPAR number : 0
      Link address  : F4 CU Logical Address : 0
Subchannel number to delete: [0]? 0
Are you sure?(Yes or [No]): y
ESCON Config Virtual>sub list
Read Subchannels:
Sub 0 Device address : 5 LPAR number : 0
      Link address  : F4 CU Logical Address : 0
Write Subchannels:
Sub 1 Device address : 6 LPAR number : 0
      Link address  : F4 CU Logical Address : 0
ESCON Config Virtual>sub mod
Read Subchannels:
Sub 0 Device address : 5 LPAR number : 0
      Link address  : F4 CU Logical Address : 0
Write Subchannels:
Sub 1 Device address : 6 LPAR number : 0
      Link address  : F4 CU Logical Address : 0
Subchannel number to modify: [0]? 1
ESCON Modify MPC+ Subchannel>d 2
ESCON Modify MPC+ Subchannel>e
ESCON Config Virtual>sub list
Read Subchannels:
Sub 0 Device address : 5 LPAR number : 0
      Link address  : F4 CU Logical Address : 0
Write Subchannels:
Sub 1 Device address : 2 LPAR number : 0
      Link address  : F4 CU Logical Address : 0
ESCON Config Virtual> exit
ESCON Config>
```

## List

Use the **list** command to list the ESCON configuration and also (with **list all**) list a subchannel summary.

**Syntax:** list (no parameters)

all

(no parameters)

Lists the ESCON configuration.

**Example:** Listing the ESCON configuration

```
ESCON Config>li
Net: 5 Protocol: LSA LAN type: Token Ring LAN number: 0
Maxdata: 2052
Loopback is enabled.
MAC address: 400022160005
```

all

Lists the ESCON configuration with a subchannel summary. Two examples are provided. The first is for an ESCON Channel Adapter with LSA subchannels. The second is for an ESCON Channel Adapter with MPC+ subchannels.

**Example for LSA and LCS:** Listing the ESCON configuration with subchannel summary

```
ESCON Config>li all
Net: 2 Protocol: LCS LAN type: LCS Ethernet LAN number: 0
      Maxdata: 1500
      MAC address: 400000002216
      Sub 0 Dev addr: 8 LPAR: 0 Link addr: C5 CU addr: 0

Net: 5 Protocol: LSA LAN type: Token Ring LAN number: 0
      Maxdata: 2052
      Loopback is enabled.
      MAC address: 400022160005
      Sub 0 Dev addr: 0 LPAR: 0 Link addr: 1 CU num: 0
```

**Example for MPC+:** Listing the ESCON configuration with subchannel summary

```
Net: 1 Protocol: MPC+ LAN type: MPC+ LAN number: 0
      Maxdata: 2048
      Reply TO: 45000 Sequencing Interval Timer: 3000
      Read Subchannels:
      Sub 0 Dev addr: 40 LPAR: 0 Link addr: F5 CU addr: 0
      Write Subchannels:
      Sub 1 Dev addr: 41 LPAR: 0 Link addr: F5 CU addr: 0

Net: 2 Protocol: MPC+ LAN type: MPC+ LAN number: 1
      Maxdata: 2048
      Reply TO: 45000 Sequencing Interval Timer: 3000
      Read Subchannels:
      Sub 0 Dev addr: 42 LPAR: 0 Link addr: F5 CU addr: 0
      Write Subchannels:
      Sub 1 Dev addr: 43 LPAR: 0 Link addr: F5 CU addr: 0
```

## Exit

Use the **exit** command to return to the previous prompt level.

**Syntax** exit

**Example:**

```
ESCON Config>exit
```





---

## Chapter 5. Monitoring the ESCON Channel Adapter

This chapter describes how to monitor the ESCON Channel Adapter. It includes the following sections:

- “Accessing the ESCON Console Process”
- “ESCON Interface Console Commands” on page 5-2
- “ESCON LCS Interface Console Commands” on page 5-5
- “ESCON LSA Interface Console Commands” on page 5-7
- “ESCON MPC+ Interface Console Commands” on page 5-10

For additional monitoring information, refer to *IBM 2216 Software User's Guide*.

---

### Accessing the ESCON Console Process

To access the ESCON interface:

1. At the OPCON prompt, enter **talk 5**. For example:

```
* talk 5
+
```

2. To display the monitoring prompt for the ESCON interface or any of the ESCON Channel Adapter's virtual interfaces, enter the **network** command followed by the interface number of the interface.

If you do not know the interface number, use the **configuration** command at the + prompt to display a list of interface numbers configured on the router.

#### Example:

```
+ configuration
Multiprotocol Access Services

5765-B87 Feature 2801 V1 R1.0 PTF 0 RPQ 0

Num Name Protocol
3 ARP Address Resolution
11 SNMP Simple Network Management Protocol

Num Name Feature
2 MCF MAC Filtering

6 Networks:
Net Interface MAC/Data-Link Hardware State
0 TKR/0 Token-Ring/802.5 Token-Ring Up
1 TKR/1 Token-Ring/802.5 Token-Ring Up
2 ESCON/0 ESCON Nways ESCON Channel Up
3 LCS/0 ESCON-LCS Nways ESCON Channel Up
4 LSA/0 ESCON-LSA Nways ESCON Channel Up
5 ESCON/1 ESCON Nways ESCON Channel Up
6 MPC/0 ESCON-MPC Nways ESCON Channel Up
```

In this example:

- To access the monitoring prompt for the ESCON Channel Adapter, enter:

```
+network 0
ESCON Console
ESCON>
```

- To access the monitoring prompt for MPC+ interface 1, enter:

## ESCON Interface Console Commands

```
+network 1
MPC+ Console
MPC+>
```

---

## ESCON Interface Console Commands

The following commands can be entered as the ESCON monitoring prompt (ESCON>):

| <i>Table 5-1. ESCON Interface Console Commands</i> |                                          |
|----------------------------------------------------|------------------------------------------|
| <b>Command</b>                                     | <b>Description</b>                       |
| <b>? (Help)</b>                                    | Lists commands or lists command options. |
| <b>List</b>                                        | Lists subchannels or lists nets.         |
| <b>Net</b>                                         | Lists a specific network interface.      |
| <b>Exit</b>                                        | Returns to the previous prompt.          |

### ? (Help)

Use the **? (Help)** command to display a list of possible commands or to display the options associated with a command.

#### Syntax ?

#### Example:

```
ESCON Config> ?
LIst
NEt
Exit
```

**Note:** Valid command abbreviations are shown in uppercase letters. For example, LIst means that you can enter LI for the **list** command.

### List

Use the **list** command to list all subchannels or to list all network interfaces.

**Syntax:** `list subchannels OR nets`

**subchannels** Lists subchannels

#### Example: List subchannels

```
ESCON> li sub
The following subchannels are defined:
  Local address: 00   Device address: 00   CU Link Address: 00
                    Link: C5   LPAR: 00
                    Type: LSA
    The following lantypes/lannums are using this subchannel:
      LAN type: Token-Ring/802.5 LAN number: 0
  Local address: 01   Device address: DD   CU Link Address: 0B
                    Link: 5C   LPAR: 02
                    Type: LSA
    The following lantypes/lannums are using this subchannel:
      LAN type: Token-Ring/802.5 LAN number: 0
  Local address: 02   Device address: 07   CU Link Address: 00
                    Link: C5   LPAR: 00
                    Type: LSA
    The following lantypes/lannums are using this subchannel:
      LAN type: Token-Ring/802.5 LAN number: 1
  Local address: 03   Device address: 02   CU Link Address: 00
                    Link: C5   LPAR: 00
                    Type: LCS
```

```
The following lantypes/lannums are using this subchannel:  
LAN type: Token-Ring/802.5 LAN number: 2  
Local address: 04 Device address: 03 CU Link Address: 00  
Link: C5 LPAR: 00  
Type: LCS
```

```
The following lantypes/lannums are using this subchannel:  
LAN type: Token-Ring/802.5 LAN number: 2
```

### *Local Address*

The subchannel address index used internally by the 2216.

### *Device Address*

The unit address transmitted on the channel path to select a 2216 device. It is also referred to as subchannel number in S/370 I/O architecture. It is a two-digit hexadecimal value that may range from X'00' to X'FF'. This value is defined in the host IOCP by the UNITADD statement on the CNTLUNIT macro instruction for the real device. It is a two-digit hexadecimal value that may range from X'00' to X'FF'. This value is defined in the host IOCP by the UNITADD statement on the CNTLUNIT macro instruction for the real device.

### *CU Logical Address*

The Control Unit address defined in the host for the 2216. This value is defined in the host Input/Output Configuration Program (IOCP) by the CUADD statement on the CNTLUNIT macro instruction.

The Control Unit Address must be unique for each LPAR defined on the same host.

### *Link Address*

If one ESCD is in the communication path, the link address is the ESCON Director (ESCD) port number that is attached to the host.

If two ESCDs are in the path, the link address is the host-side port number of the ESCD defined with the dynamic connection.

When no ESCD is in the communication path, this value must be set to 0x01.

### *LPAR*

Logical partition number. This allows multiple partitions in a logically partitioned (LPAR) host to share one ESCON fiber.

This value is defined in the host Input/Output Configuration Program (IOCP) by the RESOURCE macro instruction.

If the host is not using EMIF, the LPAR number is 0 (zero).

### *Type*

Type of virtual interface: LCS, LSA, or MPC+

### *lantype*

LAN type, either Token-Ring/802.5, Ethernet/802.3, Ethernet/V2, or Ethernet.

**Note:** This field is not displayed for subchannels that are part of an MPC+ interface.

## ESCON Interface Console Commands

### *lanumber*

Interface number of the LAN

**Note:** This field is not displayed for subchannels that are part of an MPC+ interface.

### *Group Number*

The group number is used internally by the 2216 to identify a virtual MPC+ net interface on the ESCON Channel Adapter.

**nets** Lists network interfaces.

**Example:** List networks

```
ESCON>li ne
+ net 1
ESCON Base Console
ESCON> li nets
Net: 2   Type: LSA   LAN Type: Token-Ring/802.5   LAN Number: 0
        Net state: Up
Net: 4   Type: LSA   LAN Type: Token-Ring/802.5   LAN Number: 1
        Net state: Up
Net: 5   Type: LCS   LAN Type: Token-Ring/802.5   LAN Number: 2
        Net state: Down
```

### *Type*

Type of virtual interface: LCS, LSA, or MPC+

### *Group Number*

The group number is used internally by the 2216 to identify a virtual MPC+ net interface on the ESCON Channel Adapter.

### *Net State*

State of the network: Up, Down, Disabled, Not Present, or Testing.

**Up** Indicates that the link is up.

**Down** Indicates that the link is down.

**Disabled** Indicates that the operator has disabled the link.

**Not Present** Indicates that the network interface's adapter is not present or there is a hardware mismatch.

**Testing** The system is attempting to determine if a network connection exists

## Net

Use the **net** command to get to one of the virtual interfaces as described in:

- "ESCON LCS Interface Console Commands" on page 5-5
- "ESCON LSA Interface Console Commands" on page 5-7
- "ESCON MPC+ Interface Console Commands" on page 5-10

**Syntax:** `net net_number`

**Example:** List networks

```
ESCON+> net 1
```

## Exit

Use the **exit** command to return to the previous prompt level.

```
ESCON> exit
```

---

## ESCON LCS Interface Console Commands

The following commands can be entered at the LCS monitoring prompt (LCS>):

| <i>Table 5-2. ESCON LCS Interface Console Commands</i> |                                          |
|--------------------------------------------------------|------------------------------------------|
| <b>Command</b>                                         | <b>Description</b>                       |
| <b>? (Help)</b>                                        | Lists commands or lists command options. |
| <b>List</b>                                            | Lists subchannels or lists nets.         |
| <b>Exit</b>                                            | Returns to the previous prompt.          |

## ? (Help)

Use the **? (Help)** command to display a list of possible commands or to display the options associated with a command.

**Syntax ?**

**Example:**

```
LCS> ?
List
NEt
Exit
```

**Note:** Valid command abbreviations are shown in uppercase letters. For example, LIst means that you can enter LI for the **list** command.

## List

Use the **list** command to display information for an LCS interface.

**Syntax:** `list`

**Example:**

```
LCS> list List Virtual Adapter for LCS
LCS Virtual Adapter
LCS Information for Net 4
-----
LAN Type: Token-Ring/802.5      LAN Number: 0
Read Subchannel: 7      Write Subchannel: 6
MAC Address: 400022160001
Local IP Address: 9.192.200.1
Status: Down
```

*LAN Type*

LAN type, either Token-Ring or Ethernet

*LAN Number*

Interface number of the LAN

*Read Subchannel*

The subchannel that the 2216 receives data from.

## ESCON LCS Interface Console Commands

### *Write Subchannel*

The subchannel that the 2216 transmits data from.

### *MAC Address*

A unique MAC address to identify this virtual interface.

### *Local IP address*

IP Address that was assigned to this network interface.

### *Status*

Status of the network: Up, Down, Disabled, Not Present, or Testing

**Up** The network connection is established.

**Down** The network connection can not be determined.

**Disabled** Device is disabled and diagnostic testing can be performed

**Not Present** Indicates that the network interface's adapter is not present or there is a hardware mismatch.

**Testing** The system is attempting to determine if a network connection exists

## Exit

Use the **exit** command to return to the previous prompt level.

### **Example:**

```
LCS>exit  
ESCON>
```

## ESCON LSA Interface Console Commands

The following commands can be entered at the LSA monitoring prompt (LSA>):

| <i>Table 5-3. ESCON LSA Interface Console Commands</i> |                                                         |
|--------------------------------------------------------|---------------------------------------------------------|
| <b>Command</b>                                         | <b>Description</b>                                      |
| <b>? (Help)</b>                                        | Lists commands or lists command options.                |
| <b>List</b>                                            | Lists information for adapters, SAPs, or link stations. |
| <b>Exit</b>                                            | Returns to the previous prompt.                         |

### ? (Help)

Use the **? (Help)** command to display a list of possible commands or to display the options associated with a command.

**Syntax ?**

**Example:**

```
LSA> ?
List
Exit
```

**Note:** Valid command abbreviations are shown in uppercase letters. For example, LIst means that you can enter LI for the **list** command.

### List

Use the **list** command to display information for adapters, SAPs, and link stations.

**Syntax:** `list adapter`  
`sap`  
`link stations`

**list adapter** Lists virtual adapters for LSA.

**Example:** List Virtual Adapter for LSA

```
LSA> list ad
LSA Virtual Adapter
LSA Information for Net 2
-----
LAN Type: Token-Ring/802.5      LAN Number: 0
MAC Address: 4000000000CF
Downstream network: Loopback - Net 2
Status: Host connected

#SAPs Open: 1      #Link Stations Open: 1
Maximum frame size: 2052 (0x804)
Host User ID      Subchannel
-----
00000000          0

1 host user(s)
```

*SAPs Open*

Number of SAPs opened by VTAM on this LSA interface

*#Link Stations Open*

Number of link stations open for all SAPs on this LSA interface

## ESCON LSA Interface Console Commands

### *Maximum Frame Size*

Maximum frame size supported over this LSA interface

### *Host User ID*

A unique ID generated by VTAM to identify the host user on a given subchannel

### *Subchannel*

The subchannel address index used internally by the 2216.

**list sap** Lists Service Access Points (SAPS) for LSA

### **Example:** List SAP for LSA

```
LSA> list sap
SAP    Provider    User    Max Link    Open Link
Number  SAP ID         SAP ID  Stations    Stations
-----  -
4      02000000      00000001  1           1
1 SAPs currently open
```

### *SAP Number*

Identifies the SAP to LLC

### *Provider SAP ID*

A unique ID generated by VTAM to identify this SAP

### *User SAP ID*

A unique ID generated by 2216 to identify this SAP

### *Max Link Stations*

Maximum number of link stations VTAM can open on this SAP

### *Open Link Stations*

Number of link stations currently open on this SAP

**list link** Lists link information for LSA

### **Example:** List link for LSA

```
LSA> list link
Please specify a SAP number (0-236): [4]? 4
Link Stations on SAP 4
```

| Station ID | Destination MAC Address | Destination SAP Number | Link Status | Frames Sent | Frames Received |
|------------|-------------------------|------------------------|-------------|-------------|-----------------|
| 02000001   | 40000000ABCD            | 4                      | Connected   | 9           | 9               |

1 link station(s) open on SAP 4

### *Station ID*

A unique ID generated by 2216 to identify this link station

### *Destination MAC Address*

MAC address of the remote LLC link station

### *Destination SAP Number*

SAP value of the remote LLC link station

### *LINK Status*

Current status of the LLC connection

### *Frames Sent*

Number of packets sent to VTAM for this link station



### *Frames Received*

Number of packets received from VTAM for this link station

## Exit

Use the **exit** command to return to the previous prompt level.

### **Example:**

```
LSA>exit  
ESCON>
```

## ESCON MPC+ Interface Console Commands

The following commands can be entered at the MPC+ monitoring prompt (MPC+>):

| <i>Table 5-4. ESCON MPC+ Interface Console Commands</i> |                                          |
|---------------------------------------------------------|------------------------------------------|
| <b>Command</b>                                          | <b>Description</b>                       |
| <b>? (Help)</b>                                         | Lists commands or lists command options. |
| <b>List</b>                                             | Lists subchannels or lists nets.         |
| <b>Exit</b>                                             | Returns to the previous prompt.          |

### ? (Help)

Use the **? (Help)** command to display a list of possible commands or to display the options associated with a command.

#### Syntax ?

#### Example:

```
MPC+> ?
List
Exit
```

**Note:** Valid command abbreviations are shown in uppercase letters. For example, LIst means that you can enter LI for the **list** command.

### List

Use the **list** command to display the MPC+ Group, subchannels, Connection Manager (CM), and connection information.

**Syntax:** `list mpc group  
subchannel  
cm  
connection`

#### mpc

Displays information about the MPC+ Group. It displays the local and remote registration token, if known, and the current state of the MPC+ Group.

#### Example: List MPC

```
MPC+>li mpc
MPC+ Group
Local registration token = 0901422A3C00000000
Remote registration token = 050001019D
state = Active
```

#### *Local registration token*

Token in the 2216 representing this MPC+ Group.

#### *Remote registration token*

Token in the host representing this MPC+ Group. This field is blank if not known.

#### *state*

The state of the MPC+ Group:

#### Reset

The MPC+ Group is currently inactive.

Pending Active-xid2(00)

In the process of becoming active and currently processing xid2(00)s.

Pending Active-xid2(07)

In the process of becoming active and currently processing xid2(07)s.

Active

Active and usable.

Pending Reset

Pending inactive (in other words, in the process of coming down).

**subchannel**

Shows information about the subchannels that are part of the MPC+ Group. It shows the local subchannel number, logical partition number, Link address, Control Unit (CU) logical address, Device Address, type of Subchannel (READ or WRITE), and the current state of the subchannel. The type should be the opposite of what is configured at the host.

**Example:** List subchannels for MPC+

```
MPC+>1i sub
MPC+ Subchannels
Local      Link  CU Log.  Device
number    LPAR  addr    address  address  type    state
-----
          1    0    F4      0        9      READ   Active
          0    0    F4      0        8      WRITE  Active
```

*Local number*

The subchannel address index used internally by the 2216.

*LPAR*

Logical partition number. This allows multiple partitions in a logically partitioned (LPAR) host to share one ESCON fiber.

This value is defined in the host Input/Output Configuration Program (IOCP) by the RESOURCE macro instruction.

If the host is not using EMIF, the LPAR number is 0 (zero).

*Link Address*

If one ESCD is in the communication path, the link address is the ESCON Director (ESCD) port number that is attached to the host.

If two ESCDs are in the path, the link address is the host-side port number of the ESCD defined with the dynamic connection.

When no ESCD is in the communication path, this value must be set to 0x01.

*CU Logical Address*

The Control Unit address defined in the host for the 2216. This value is defined in the host Input/Output Configuration Program (IOCP) by the CUADD statement on the CNTLUNIT macro instruction.

The Control Unit Address must be unique for each logical partition defined on the same host.

*Device Address*

The unit address transmitted on the channel path to select a 2216 device. It is also referred to as subchannel number in S/370 I/O architecture. It is a two-digit hexadecimal value that may range from X'00' to X'FF'. This value is defined in the host IOCP by the UNITADD statement on the CNTLUNIT macro instruction for the real device. It is a two-digit

## ESCON MPC+ Interface Console Commands

hexadecimal value that may range from X'00' to X'FF'. This value is defined in the host IOCP by the UNITADD statement on the CNTLUNIT macro instruction for the real device.

### *type*

Whether this is a read or write subchannel.

### *state*

The state of the subchannel:

#### Reset

The subchannel is currently inactive.

#### Pending Active-xid2(00)

The subchannel is becoming active and currently processing xid2(00)s.

#### Pending Active-xid2(07)

The subchannel becoming active and currently processing xid2(07)s.

#### Active

The subchannel is active and part of an MPC+ Group.

#### Pending Reset

The subchannel is pending inactive (in other words, in the process of coming down).

## **cm**

Shows information on the Connection Manager that is running on the MPC+ Group. The information shown is the group token, the type of connection manager, and the current state.

The states are:

#### Reset

The CM is currently inactive.

#### Pending Active-waiting for MPC+ Group

The underlying MPC+ Group is coming active.

#### Pending Active-other side

The other side has initiated bring-up of the CM but this side has not started to initiate bring-up of the CM.

#### Pending Active-this side

This side has initiated bring-up of the CM but the other side has not started to initiate bring-up of the CM.

#### Pending Active-callee

This side is waiting for the other side, which is the caller in this bring-up to start the call.

#### Pending Active-caller

This has called out to the other side and is waiting for the other side to response to the call.

#### Active

Active and usable

**Example:** List an active CM for MPC+

```
MPC+>11 cm
MPC+ Connection Managers(CM)
      Group Token   type   state
-----
090144953400000009      PTP Active
```

**Example:** List, no active CM for MPC+

```
MPC+>11 cm
No CMs on this MPC+ Group
```

### **connection**

Shows information on the connections running on the MPC+ Group/Connection Manager. The information shown is in two parts: the virtual circuit and the connections under the virtual circuit. The following information is shown for the virtual circuit: the local and remote virtual circuit tokens, the protocol type, and the current state.

#### *Local Virtual Circuit Token*

Token in the 2216 representing this virtual circuit.

#### *Remote Virtual Circuit Token*

Token in the host representing this virtual circuit. This field is blank if not known.

#### *Protocol*

The upper layer protocol that this virtual circuit is using.

#### *States for the Virtual Circuit*

The states for the virtual circuit are:

##### Reset

The virtual circuit is currently inactive

##### Active-other side

The other side is currently accepting calls (connections) for this virtual circuit.

##### Active-this side

This side is currently accepting calls (connections) for this virtual circuit.

##### Active-both sides

Both sides of the virtual circuit are accepting calls (connections) for this virtual circuit.

##### Not accepting new calls

This connection is not accepting new calls (connections). However, connections that are already running on the virtual circuit will stay up.

The information shown for the connection is the local and remote connection tokens and the current state.

#### *Local Connection Token*

The token in the 2216 representing this connection.

#### *Remote Connection Token*

The token in the host representing this connection. This field is blank if not known.

#### *States for the Connection*

The states for the connection are:

##### Reset

The connection is currently inactive

## ESCON MPC+ Interface Console Commands

Pending Active - callee

This side is about to respond to the call request from the other side.

Pending Active - caller

This has called out to the other side and is waiting for the other side to response to the call.

Pending Active - awaiting datastart

The connection is waiting for both sides to be ready to start allowing user data to flow.

Active

Active and usable

**Example:** List, active connection for MPC+

```
MPC+>1i conn
MPC+ Connections
Local Virtual Circuit Token = 090144C22C0000000D
Remote Virtual Circuit Token = 05000101A5
Protocol = APPN, State = Active-both sides
Local Connection Token = 090144C3300000000E
Remote Connection Token = 05000101A6
State = Active
```

**Example:** List, no connections active for MPC+

```
MPC+>1i conn
No User Connections on this MPC+ Group
```

## Exit

Use the **exit** command to return to the previous prompt level.

**Example:**

```
MPC+>exit
ESCON>
```

---

## Chapter 6. Network Management for the ESCON Channel Adapter

The IBM 2216 provides a Simple Network Management Protocol (SNMP) interface to network management platforms and applications, such as the Nways Campus Manager products.

SNMP is used for monitoring and managing IP hosts in an IP network and uses software called an SNMP agent to enable network hosts to read and modify some of the 2216's operational parameters. In this way, SNMP establishes network management for the IP community.

You need to consider the following aspects of SNMP when you configure SNMP for your IBM 2216:

**Community** The community allows you to define the IP address of the SNMP management station that is allowed to access the information in the SNMP agent's management information base (MIB). You define a community name for use in accessing the MIB.

**Authentication** The community name is used as an authentication scheme to prevent unauthorized users from learning information about an SNMP agent or modifying its characteristics.

This scheme involves defining one or more sets of MIB data (referred to as MIB views) and associating an access privilege (read-only, read-write), an IP mask, and a community name with each MIB view. The IP mask establishes which IP addresses can originate access requests for a given MIB view and the community name serves as a password that must be matched by the SNMP requests. The community name is included in each SNMP message and verified by the IBM 2216 SNMP agent.

An SNMP request will be rejected if it does not provide the correct community name, does not match the IP mask, or attempts an access that is inconsistent with the assigned access privilege.

**MIB Support** A management information base (MIB) defines operational variables.

A MIB is a virtual information store that provides access to management information. This information is defined as MIB objects that can be accessed and, in some cases, modified using network management tools.

The IBM 2216 provides a comprehensive set of standard and enterprise-specific MIBs for monitoring and managing resources.

You can access readme files documenting the 2216 MIB support using the World Wide Web at URL:

**`ftp://ftp.nways.raleigh.ibm.com/`**

in the appropriate release level directory under  
`/pub/netmgmt/2216/`

## Network Management for the ESCON Channel Adapter

**Trap Messages** Trap messages are unsolicited messages sent from the SNMP agent in the 2216 to an SNMP manager in response to a 2216 or network condition, such as a 2216 reload or network down.

### IBM 2216 ESCON Supported MIBs

Table 6-1 lists MIB support for the IBM 2216 ESCON Channel Adapter.

| <b>Group Name</b>                    | <b>Supported</b> | <b>Not Supported</b> |
|--------------------------------------|------------------|----------------------|
| esconPortTable                       | √                |                      |
| esconPortEntry                       |                  |                      |
| esconPortControlUnitLinkAddress      | √                |                      |
| esconPortInFiberStatus               | √                |                      |
| esconPortOutFiberStatus              | √                |                      |
| esconLinkTable                       |                  |                      |
| esconLinkEntry                       |                  |                      |
| esconLinkHostLinkAddress             | √                |                      |
| esconLinkPartitionNumber             | √                |                      |
| esconLinkStatus                      | √                |                      |
| esconStationTable                    |                  |                      |
| esconStationEntry                    |                  |                      |
| esconStationHostLinkAddress          | √                |                      |
| esconStationPartitionNumber          | √                |                      |
| esconStationDeviceAddress            | √                |                      |
| esconStationState                    | √                |                      |
| esconStationAttentionDelay           |                  | √                    |
| esconStationAttentionTimeout         |                  | √                    |
| esconStationMaxBfru                  |                  | √                    |
| esconStationUnitSize                 |                  | √                    |
| esconStationMaxMsgSizeReceived       | √                |                      |
| esconStationMaxMsgSizeSent           | √                |                      |
| esconStationDataPacketsOkReceived    | √                |                      |
| esconStationDataPacketsKoReceived    |                  | √                    |
| esconStationDataPacketsSent          | √                |                      |
| esconStationTotalFramesSent          | √                |                      |
| esconStationDataPacketsRetransmitted |                  | √                    |
| esconStationPositiveAckDataPackets   |                  | √                    |
| esconStationSecondChanceAttentions   |                  | √                    |
| esconStationCommandsRetried          |                  | √                    |



---

## Appendix A. Diagnostic Testing of the ESCON Channel Adapter

Both hardware and software (operational code and configuration) problems can affect the IBM 2216. Light-emitting diodes (LEDs), diagnostic programs, and error messages provide information needed for problem determination. This appendix presents information on diagnosing problems with the IBM 2216 ESCON adapter hardware only.

For diagnostic testing of the 2216, refer to *Service and Maintenance Manual*.

---

### Diagnosing Operational Code and Configuration Problems

Errors that occur **after** the operational code is loaded may indicate problems with the operational code or configuration file. See Appendix D, "ELS Messages" on page D-1 for Error Codes and corrective actions.

---

### Diagnosing Hardware Problems

Generally, errors that occur **before** the operational code is loaded are hardware-related. LEDs on the front of the IBM 2216 are indicators of faults with hardware components within the IBM 2216. See Appendix C, "LED Indicators for the ESCON Channel Adapter" on page C-1 for LED status and indicators for the ESCON Adapter. To complete initial testing of the IBM 2216 ESCON Channel Adapter after installation, refer to Chapter 3, "Testing the ESCON Channel Adapter" on page 3-1. Additional diagnostic procedures and information follow as reference material.

### Invoking the IBM 2216 Diagnostic Function

The following steps will guide you through use of IBM 2216 diagnostic function.

- 1 Obtain the console from the command line interface. See Chapter 3, "Testing the ESCON Channel Adapter" on page 3-1 for information on how to acquire the command line interface.

```
Please press the space bar to obtain the console.
```

```
Disk Load: Using bank A and config number 1  
Console granted to this interface
```

```
*
```

**2** Enter **diags** to invoke the online diagnostic function. The Diagnostic Menu will appear.

```

Diagnostic Menu                                     Screen 1 of 1

Select from the following list of functions:

< 1. The Device Status Page >
  shows operational and diagnostic status for each of the installed adapters.
  From this page you can also link to the Test Control Page for each adapter.

< 2. The Diagnostic Test History Log >
  contains a summary of recent testing activity.

< 3. The Diagnostic Error Log >
  contains error information for recent diagnostic tests that have detected
  errors.

First time users should review the < 4. Introduction > to using the
diagnostics.

Select (1-4 or E=Exit Diagnostics ):1
    
```

**3** Enter **1** to access the Device Status Page (option 1). The system will display a list of installed devices and a summary status for each as follows.

```

Device Status Page                                 Screen 1 of 1

For more information and Test Control Menus for devices...
Select from the following list:

Device      Location      Multi-Port  Adapter  Status
Token Ring  Slot 1      Multi-Port  Adapter  ENABLED
< 1. Token Ring > Slot 1      Port 1      Net # 0  ENABLED
< 2. Token Ring > Slot 1      Port 2      Net # 1  ENABLED
< 3. ESCON >   Slot 3      Single Port  Net # 2  ENABLED
< 4. ESCON >   Slot 4      Single Port  Net # 3  ENABLED

Select (1-2 or B=Back R=Refresh H=Help ):
    
```

The following list describes information that may appear in the status field:

- ENABLED** Device is enabled for normal operation.
- ENABLE PENDING** Device is waiting for completion of Enable request.
- DISABLED** Device is disabled and diagnostic testing can be performed.
- DISABLE PENDING** Device is waiting for completion of Disable request.
- MESSAGE** A message has been issued for this device (you can select the Device to view and respond to the message).
- TESTING** Device is being tested.
- NOT CONFIGURED** Device is not configured for normal operation.
- MIS CONFIGURED** Configuration does not match the physical device.
- HARDWARE ERROR** A hardware error has been detected which prevents the further used of the device.

## Using the ESCON Adapter Diagnostic Functions

Once you have invoked the IBM 2216 diagnostic functions and have navigated to the Device Status Page, you can select an ESCON channel adapter from the list of testable devices. At this point, the Test Control Menu for the chosen ESCON adapter will appear.

```

                                     Test Control Menu
                                     Screen 1 of 1

LIC 287 - ESCON Channel Adapter, Slot 4, Net # 0

Operational Status  Diagnostic Status  Fault Status  Network Connection
      ENABLED           INACTIVE           UNKNOWN           UP

Select from the following:
  < 1. Disable Device >
      Enable Device
      Run Default Test
      Run Interactive Test
      Loop Test - stop on first error
      Loop Test - Log all errors
      Stop Test
  < 2. View Test History Log >
  < 3. View Hardware Error Log >

Select (1-3 or B=Back R=Refresh H=Help ):1
    
```

The Operational Status field is equivalent to the Status field of the Device Status Page for which definitions are listed on page A-2.

The following list describes information that may appear in the Diagnostic Status field:

|                         |                                                                                                           |
|-------------------------|-----------------------------------------------------------------------------------------------------------|
| <b>INACTIVE</b>         | The diagnostic for the device is not running.                                                             |
| <b>RUNNING</b>          | A testing process for the device is active and the device is being tested.                                |
| <b>LOOP AND LOG</b>     | A testing process for the device is active and will loop and log any errors until stopped.                |
| <b>LOOP UNTIL ERROR</b> | A testing process for the device is active and will loop until an error occurs or it is stopped.          |
| <b>MESSAGE</b>          | A message has been issued for this device (you can select the device to view and respond to the message). |

The following list describes information that may appear in the Fault Status field:

|                     |                                                                             |
|---------------------|-----------------------------------------------------------------------------|
| <b>OK</b>           | The last test of the device completed without error.                        |
| <b>ISOLATED</b>     | A hardware failure has been detected and isolated to the device.            |
| <b>NON-ISOLATED</b> | A problem has been detected, but the failure may be external to the device. |
| <b>UNKNOWN</b>      | No test results are currently available for the device.                     |

## ESCON Diagnostics

The following list describes information that may appear in the Network Connection field:

|                |                                                                         |
|----------------|-------------------------------------------------------------------------|
| <b>UP</b>      | The network connection is established.                                  |
| <b>DOWN</b>    | The network connection cannot be detected.                              |
| <b>TESTING</b> | The system is attempting to determine if a network connection exists.   |
| <b>UNKNOWN</b> | The state of the network connection can not be determined at this time. |
| <b>N/A</b>     | Network Status does not apply to this device.                           |

The selections available on the Test Control Menu depend on the state of the device. In the example Test Control Menu on page A-3, the device is ENABLED, so the only options available are to disable the device or view log information. In the following example, the device has been DISABLED. Notice that more options have become available for the device.

```

                                     Screen 1 of 1
                               Test Control Menu

LIC 287 - ESCON Channel Adapter, Slot 4, Net # 0

Operational Status  Diagnostic Status  Fault Status  Network Connection
      DISABLED           INACTIVE           UNKNOWN           UNKNOWN

Select from the following:
      Disable Device
    < 1 Enable Device >
    < 2 Run Default Test >
    < 3 Run Interactive Test >
    < 4 Loop Test - stop on first error >
    < 5 Loop Test - Log all errors >
      Stop Test
    < 6. View Test History Log >
    < 7. View Hardware Error Log >

Select (1-7 or B=Back R=Refresh H=Help):
```

You can select the following options for execution from the Test Control Menu:

**Disable Device**

Disables the device from normal operation and allow diagnostic testing.

**Enable Device**

Enables the device for normal operation. (Select this option once diagnostic testing is complete.)

**Run Default Test**

Runs the default test on the ESCON Adapter, including each of the following tests:

**PCI bus**

Verifies that PCI bus functions correctly. DMA and interrupt tests are performed.

**Processor**

Tests the i80960 processor interrupt and fault detection capability. All 248 allowable interrupts are tested.

**Memory**

Verifies that memory is functioning correctly using various pattern, walking, address in address, and byte tests.

**Timer**

Verifies the functionality of onboard timers, including tests for timer running, timer decrementing, interrupt status bit, interrupt capability, reset and continue.

**Memory protection**

Ensures that memory protection function is working for packet memory, instruction memory, and I/O space. Checks four memory states:: read-only, write-only, read/write, and inaccessible.

**AIB**

Executes a series of tests on the serial engine including register, chip, and bus tests.

**Run Interactive Test**

Displays the Test Options menu, which provides additional tests as well as the ability to run an isolated test unit. See "Interactive Test Options" on page A-6 for additional information.

**Loop Test - Stop on First Error**

Displays the Test Options menu. It is designed to continually test a device once the desired options are selected. (The Optical Power and Light Reception tests are not available as looping tests.)

The test automatically stops on the occurrence of the first error or if specifically requested (see Stop Test below).

**Loop Test - Log All Errors**

Displays the Test Options menu. It is designed to continually test a device once the desired options are selected. (The Optical Power and Light Reception tests are not available as looping tests.)

This test will not stop unless explicitly requested to do so (see Stop Test below). Any errors detected are recorded in the hardware error log.

**Stop Test**

Ends the diagnostic testing that is currently in progress.

**View Test History Log**

Shows the test history log for this device.

**View Hardware Error Log**

Shows the error information that has been recorded for this device.

## Interactive Test Options

The Test Options menu is displayed in response to a Run Interactive Test request on the Test Control Menu. Both test suites and individual tests are available to allow you to examine the entire adapter or isolate its various components.

```

                                     Screen 1 of 1
                                Test Options

LIC 287 - ESCON Channel Adapter, Slot 4, Net # 0

Operational Status  Diagnostic Status  Fault Status  Network Connection
      DISABLED           MESSAGE           UNKNOWN           UNKNOWN

Do not remove this device while testing.
Select one of the following test options:
* < 1. Run all tests excluding external wrap test >
* < 2. Run all tests including external wrap test >
  Individual tests:
* < 3. PCI BUS >
* < 4. PROCESSOR >
* < 5. MEMORY >
* < 6. MEMORY PROT >
* < 7. TIMER >
* < 8. AIB >
* < 9. WRAP PLUG >
* <10. OPTICAL POWER >
* <11. LIGHT RECEPTION >

Select (1-11 or B=Back R=Refresh H=Help ):
    
```

Option 1 on the Test Options menu runs all tests except the external wrap test. Option 2 runs the first test set and the wrap test. The remaining options, 3 to 11 enable the execution of tests individually.

If you select option 3, 4, 6, or 7, the results will be displayed immediately.

If you select test option 1, 2, 5, 8, 9 or 11 (all long-running tests) the result may not be available for a few minutes. In this case, the test will continue to run and the Test Control Menu will be displayed again.

If you select option 1, 2, 5, 8, 9, or 11, you will also notice that the Operational Status field indicates "TESTING." In these instances, you will need to refresh the screen until the system displays your test results. Option 10 is also a long-running test, but selection of this option does not invoke the Test Control Menu. Instead, the system displays a panel that allows you to end the test at your convenience.

The individual tests are the same tests that run as part of the default tests described previously. However, there are a few additional tests that are available only from the Test Options menu:

They are described below:

### Wrap plug

Option 9 runs the AIB test unit and an optical (external) wrap test. The wrap test requires that the fiber be removed and a wrap plug be installed. For an example of using this function, see Chapter 3, "Testing the ESCON Channel Adapter" on page 3-1.

- Optical power** Option 10 runs the AIB test unit and allows you to measure the optical output of the adapter. This test requires that the fiber be removed and an optical power meter be attached. See “Optical Power Measurement Test” on page A-7 for additional information.
- Light reception** Option 11 runs the AIB test unit and also tests whether the attached fiber is transmitting light. This test can be used to determine if the remote end of the fiber is connected. For an example of using this function, see Chapter 3, “Testing the ESCON Channel Adapter” on page 3-1.

## Optical Power Measurement Test

The following example describes the use of option **10**, Optical Power.

- 1 Enter **10** on the Test Options panel to run the optical power meter test.

```

                                Test Options
                                Screen 1 of 1

LIC 287 - ESCON Channel Adapter, Slot 4, Net # 0

Operational Status Diagnostic Status Fault Status Network Connection
      DISABLED           MESSAGE           UNKNOWN           UNKNOWN

Do not remove this device while testing.
Select one of the following test options:
* < 1. Run all tests excluding external wrap test >
* < 2. Run all tests including external wrap test >
  Individual tests:
* < 3. PCI BUS >
* < 4. PROCESSOR >
* < 5. MEMORY >
* < 6. MEMORY PROT >
* < 7. TIMER >
* < 8. AIB >
* < 9. WRAP PLUG >
* <10. OPTICAL POWER >
* <11. LIGHT RECEPTION >

Select (1-11 or B=Back R=Refresh H=Help ):10
  
```

The optical power measurement test verifies that the ESCON channel adapter in the slot indicated is operating correctly and that the receive input level is within tolerance.

This test assumes that you have the following equipment installed:

- Optical Power Meter
- Duplex-to-Duplex Coupler
- Duplex-to-Biconic Test Cable

If you do not have the correct equipment, or wish to bypass this test, reinstall the fiber (if you removed it) and select **B** to return.

Using the materials previously listed to complete the test, perform the following steps:

1. Ensure that the black cap is over the biconic receptacle at the top of the power meter.
2. Press power On/Off. AUTO OFF appears on the display.

3. Allow a two minute warmup. The meter turns off if you do not press a button within 10 minutes.
4. If the meter does not display **Optical Power Meter**, repeatedly press the lambda pushbutton until 1300 nm appears.

**Note:** To ensure that the pushbutton produces the desired results, do not hold down the pushbutton for more than half a second.

5. Press Zero. The following two displays appear:
  - A value between 0.30 and 0.70 nanowatts (nW)
  - After a short time **0** blinks, indicating that the meter is correctly zeroed.If the meter is not correctly zeroed, a Hi or Lo is displayed after you press Zero. Press Zero again, and using a jeweler's screwdriver, adjust the trim pot that is beside the biconic receptacle at the top of the meter until a value between 0.30 and 0.70 nW is displayed. Set the value to 0.50, if possible.
6. Press Zero again to zero the meter.

The meter must also display dBm. If nW is displayed, press dBm/Watt. The optical power meter is now set.
7. After you set the meter, connect the black biconic connector of the test cable to the biconic receptacle on top of the power meter.
8. Enter **1** to start the test as indicated in the following example.

```

                                     Setup For Optical Test                               Screen 1 of 1
LIC 287 - ESCON Channel Adapter, Slot 4, Net # 0
Operational Status  Diagnostic Status  Fault Status  Network Connection
  DISABLED          TESTING           UNKNOWN      UNKNOWN
Do not remove this device while testing.
Install the duplex-to-biconic test cable connector to the ESCON
channel adapter located in slot 4.
Set the optical power meter to the following options:
* -- Power turned on
* -- Set for 1300 nanometers (nm)
* -- Zeroed
* -- The decibel scale displayed (dBm)
Confirm the meter is set.
< 1. Start > the adapter transmitter.
Select (1 or B=Back R=Refresh H=Help ):1
```

The green port LED on the 2216 ESCON Adapter will start blinking once the adapter has started transmitting the idle sequences. At this point, record the signal level displayed on the power meter. A correctly functioning 2216 ESCON adapter should have a power level of -21.0 dBm or more (for example, -18.0 dBm).

9. Replace the ESCON Channel Adapter if its power level is too low.



10. Enter 1 from the Optical Test in Progress panel to Stop the test.

```

                                Screen 1 of 1
                                Optical Test In Progress

LIC 287 - ESCON Channel Adapter, Slot 4, Net # 0

Operational Status  Diagnostic Status  Fault Status  Network Connection
  DISABLED          TESTING           UNKNOWN      UNKNOWN

Do not remove this device while testing.

The green PORT LED should now be flashing on the ESCON channel
adapter in slot 4, indicating that it is transmitting IDLE sequences.
You may now record the power level displayed on the optical power meter
A properly functioning ESCON should have a power level of -21.0dBm or more
(for example -18.0dBm).

Select < 1. Stop > test when you have finished
measuring the signal level.

Select (1 or B=Back R=Refresh H=Help ): 1
    
```

11. The following Test Results panel is displayed when you stop the test.

```

                                Screen 1 of 1
                                Test Results

LIC 287 - ESCON Channel Adapter, Slot 4, Net # 0

Operational Status  Diagnostic Status  Fault Status  Network Connection
  DISABLED          INACTIVE         OK           UNKNOWN

The Test Completed with No Errors.

Select ( B=Back ):
    
```



---

## Appendix B. Factory Plugging Defaults for the ESCON Channel Adapter

IBM 2216s assembled at the factory follow the plugging rules that are described in this appendix.

---

### Assumptions

- No more than **six** of any combination of Token-Ring (FC 2280) and Ethernet (FC 2281) adapters will be installed.
- If a combination of **six** FC 2280 and FC 2281 adapters is to be installed, no other adapters will be installed.
- If a combination of **five** FC 2280 and FC 2281 adapters is to be installed, then **two** additional adapters can also be installed.
- A maximum of **four** ISDN adapters (FC 2283 or FC 2292) can be installed.
- A maximum of **two** ATM adapters (FC 2284 and FC 2293) can be installed.
- A maximum of **four** ESCON adapters (FC 2287) can be installed.

---

### Plugging Sequences

Table B-1 illustrates how the slots are numbered: two rows of four slots, numbered 1 through 8:

|        |        |        |        |
|--------|--------|--------|--------|
| Slot 1 | Slot 2 | Slot 3 | Slot 4 |
| Slot 5 | Slot 6 | Slot 7 | Slot 8 |

Table B-2 illustrates how FC 2280 and FC 2281 are installed left to right, beginning with slot 1. A maximum of six can be installed in any single 2216.

|   |   |   |  |
|---|---|---|--|
| 1 | 3 | 5 |  |
| 2 | 4 | 6 |  |

Table B-3 shows the default sequence of installation for the other various adapters, installed right-to-left in the first-available slot beginning with slot 8 on the bottom and far right.

|   |   |   |   |
|---|---|---|---|
| 8 | 6 | 4 | 3 |
| 7 | 5 | 2 | 1 |



---

## Appendix C. LED Indicators for the ESCON Channel Adapter

The IBM 2216 ESCON Adapter has a number of light emitting diodes (LEDs) that indicate how the unit is functioning. This appendix explains how to determine the status of the ESCON Channel Adapter by observing these indicators.

---

### ESCON Adapter LEDs

While the operational (router) code is running, the following LED states are applicable:

**Green** ON - The adapter has been detected by the 2216.

**Yellow** ON - A card fault has been detected.

**Wrong Slot (yellow)** ON - The adapter is in the wrong slot.

The wrong slot LED is ON only when an adapter that is plugged into the 2216 violates the plugging rules described in Appendix B, "Factory Plugging Defaults for the ESCON Channel Adapter" on page B-1.

**Green Port LED** ON - The adapter is enabled and configured.

OFF - The adapter is disabled or not configured.

**Yellow Port LED** ON - There is a hardware failure.

BLINKING - There is a cable failure or a hardware failure.

OFF - No problem has been detected.

While diagnostics are running, the following states are applicable or replace those defined above:

**Green** BLINKING - The optical power measurement test is running.

**Yellow Port LED** BLINKING - A problem was detected that could not be isolated to the ESCON adapter hardware.



---

## Appendix D. ELS Messages

This chapter describes new and changed ELS messages:

- “ESCON Network Interface (ESC) Messages”
- “LCS Virtual Network Interface (LCS) Messages” on page D-12
- “LSA Virtual Network Interface (LSA) Messages” on page D-16
- “MPC+ Virtual Network Interface (MPC) Messages” on page D-28
- “Logical Link Control (LLC) Messages” on page D-34

---

### ESCON Network Interface (ESC) Messages

This chapter describes ESCON Network Interface (ESC) messages. For information on message content and how to use the message, refer to the “Introduction” in *ELS Messages*.

---

#### ESC.001

**Level:** ALWAYS

**Short Syntax:** ESC.001 bd frm LANtype *lan\_type* LANnum *lan\_num* on nt *network*

**Long Syntax:** ESC.001 frame received for unknown LAN type *lan\_type*, LAN number *lan\_num* on network *network*

**Description:** A frame was received from the channel destined for an unknown LAN type or LAN number.

---

#### ESC.002

**Level:** ALWAYS

**Short Syntax:** ESC.002 bd not *not\_id* on nt *network*

**Long Syntax:** ESC.002 unknown notification *not\_id* received from device driver on network *network*

**Description:** A notification was received from the device driver that was unknown.

---

#### ESC.003

**Level:** UE-ERROR

**Short Syntax:** ESC.003 bd 8232 cmd *cmd* on nt *network*

**Long Syntax:** ESC.003 unknown 8232 command *cmd* received on network *network*

**Description:** An 8232 command was received that was unknown.

---

#### ESC.004

**Level:** ALWAYS

**Short Syntax:** ESC.004 bd cmd *cmd* on nt *network*

**Long Syntax:** ESC.004 unknown IORB command *cmd* received on network *network*

**Description:** An IORB was received that contained an unknown command.

---

**ESC.005**

**Level:** ALWAYS

**Short Syntax:** ESC.005 no subch on nt *network*

**Long Syntax:** ESC.005 no subchannels are defined on network *network*, cannot pass self-test

**Description:** There are no subchannels defined for an ESCON base net so the network cannot be activated (pass self-test).

**Cause:** The virtual net handler(s) for this base net handler has (have) not been defined correctly.

**Action:** Define subchannels for the virtual net handler(s) on this ESCON adapter.

---

**ESC.006**

**Level:** UI-ERROR

**Short Syntax:** ESC.006 STOP: no IORB on nt *network*

**Long Syntax:** ESC.006 network *network* was unable to send a STOP command to the device driver because an IORB was not available

**Description:** The network was unable to complete deactivation because there was no IORB available with which to send the STOP command to the device driver.

---

**ESC.007**

**Level:** P-TRACE

**Short Syntax:** ESC.007 frm sent to lt *lantype* ln *lannumber* on nt *network*

**Long Syntax:** ESC.007 A frame was sent to LAN type *lantype*, LAN number *lannumber* on network *network*

**Description:** A frame was received on the channel and sent to a virtual net handler.

---

**ESC.008**

**Level:** P-TRACE

**Short Syntax:** ESC.008 data frm rcvd from nt *network*

**Long Syntax:** ESC.008 A data frame was received from network *network*

**Description:** A data frame was received from a virtual net handler to send to the channel.

---

**ESC.009**

**Level:** P-TRACE

**Short Syntax:** ESC.009 cmd *cmd\_code* in frm rcvd from nt *network*

**Long Syntax:** ESC.009 command *cmd\_code* in frame received from network *network*

**Description:** A command frame was received from a virtual net handler to send to the channel.

---

**ESC.010**

**Level:** P-TRACE

**Short Syntax:** ESC.010 notif *notif\_code* rcvd on nt *network*

**Long Syntax:** ESC.010 notification *notif\_code* received from device driver on network *network*

**Description:** A notification was received from the device driver.



---

**ESC.011**

**Level:** P-TRACE

**Short Syntax:** ESC.011 8232 cmd *cmd\_code* rcvd on nt *network*

**Long Syntax:** ESC.011 8232 command *cmd\_code* received on network *network*

**Description:** An 8232 command was received by the base net handler.

---

**ESC.012**

**Level:** C-TRACE

**Short Syntax:** ESC.012 nt *virtual\_net\_number* reg on nt *network*

**Long Syntax:** ESC.012 Network number *virtual\_net\_number* registering on base network *network*

**Description:** A virtual net handler is registering with an ESCON base net handler.

---

**ESC.013**

**Level:** P-TRACE

**Short Syntax:** ESC.013 Cmd *cmd\_code* fail stat *cmd\_status* on nt *network*

**Long Syntax:** ESC.013 Command *cmd\_code* to device driver failed with status *cmd\_status* on network *network*

**Description:** A command that the base net handler sent to the device driver has failed.

---

**ESC.014**

**Level:** P-TRACE

**Short Syntax:** ESC.014 Cmd *cmd\_code* sent to DD on nt *network* (sub *locaddr locaddr* *devaddr devaddr* *logpath logpath* )

**Long Syntax:** ESC.014 Commands *cmd\_code* was sent to the device driver on network *network* (subchannel local address *locaddr*, device address *devaddr*, logical path *logpath*)

**Description:** A command was sent to the device driver.

---

**ESC.015**

**Level:** P-TRACE

**Short Syntax:** ESC.015 Snd 8232 resp *cmd\_code* (rc *retcode*) on nt *network* (sub *locaddr locaddr* *devaddr devaddr* *logpath logpath* )

**Long Syntax:** ESC.015 Sending 8232 response for command *cmd\_code* with return code *retcode* on network *network* (subchannel local address *locaddr*, device address *devaddr*, logical path *logpath*)

**Description:** An 8232 response was sent to the host.

---

**ESC.016**

**Level:** P-TRACE

**Short Syntax:** ESC.016 Snd not *notification\_id* to net *virt\_net\_number* on nt *network*

**Long Syntax:** ESC.016 Sending notification *notification\_id* to net *virt\_net\_number* on network *network*

**Description:** A notification was sent to a virtual net handler from the base net handler.

---

---

**ESC.017****Level:** U-TRACE**Short Syntax:** ESC.017 circdn for nt *net\_num* on nt *network***Long Syntax:** ESC.017 circdown for net *net\_num* called on network *network***Description:** The circuit down routine for a network has been called.

---

**ESC.018****Level:** U-TRACE**Short Syntax:** ESC.018 circup for nt *net\_num* on nt *network***Long Syntax:** ESC.018 circup for net *net\_num* called on network *network***Description:** The circuit up routine for a network has been called.

---

**ESC.019****Level:** U-TRACE**Short Syntax:** ESC.019 net up for nt *net\_num* on nt *network***Long Syntax:** ESC.019 net up for net *net\_num* called on network *network***Description:** The net up routine for a virtual network has been called.

---

**ESC.020****Level:** U-TRACE**Short Syntax:** ESC.020 net dn for nt *net\_num* on nt *network***Long Syntax:** ESC.020 net down for net *net\_num* called on network *network***Description:** The net down routine for a virtual network has been called.

---

**ESC.035****Level:** C-INFO**Short Syntax:** ESC.035 ESCON adapter in slot *slot* is operational.**Long Syntax:** ESC.035 ESCON adapter in slot *slot* is operational.**Description:** The ESCON adapter is operational. The adapter has not yet made a connection to the host.

---

**ESC.036****Level:** UI-ERROR**Short Syntax:** ESC.036 ESCON adapter error, slot= *slot*, subchan= *subchan*, correl=0x *correl*, origcmd=0x *origcmd*, sev= *sev*, rc=0x *rc*.**Long Syntax:** ESC.036 ESCON DD received an Error notif from slot *slot* ESCON adapter; subchan= *subchan*, correl=0x *correl* origcmd=0x *origcmd*, severity= *sev*, rc=0x *rc*.**Description:** The ESCON adapter is reporting an error to the ESCON device driver.**Action:** Typically, no action is required. If the problem persists, contact Software Support. Refer to the documentation for further information.

---

**ESC.037**

**Level:** UI-ERROR

**Short Syntax:** ESC.037 ESCON adapter in slot= *slot* is offline to the host.

**Long Syntax:** ESC.037 ESCON adapter in slot= *slot* is offline to the host.

**Description:** The ESCON adapter is reporting that it is offline to the host. The adapter will be automatically restarted. Diagnostics will be invoked if the adapter fails to restart.

**Action:** If the adapter passes diagnostics but fails to start, contact Software Support.

---

**ESC.038**

**Level:** UI-ERROR

**Short Syntax:** ESC.038 ESCON DD received i960 Processor Fault notif from slot= *slot* ESCON adapter, Fault Type=0x *ft*.

**Long Syntax:** ESC.038 ESCON DD received an i960 Processor Fault notif from slot *slot* ESCON adapter with Fault Type=0x *ft*.

**Description:** The ESCON adapter is reporting that it had an i960 processor fault. The adapter will be automatically restarted. Diagnostics will be invoked if the adapter fails to start.

**Action:** Contact Software Support.

---

**ESC.039**

**Level:** UI-ERROR

**Short Syntax:** ESC.039 ESCON DD received SLC2 NMI Detected notif from slot= *slot* ESCON adapter.

**Long Syntax:** ESC.039 ESCON DD received an SLC2 NMI Detected notif from slot *slot* ESCON adapter.

**Description:** The ESCON adapter is reporting that it detected an SLC2 NMI error. The adapter will be automatically restarted. Diagnostics will be invoked if the adapter fails to restart.

**Cause:** This may be the result of disconnecting the ESCON fiber from the ESCON adapter and then reconnecting it.

**Action:** Contact Software Support.

---

**ESC.040**

**Level:** U-INFO

**Short Syntax:** ESC.040 ESCON adapter in slot *slot* had an unexpected interrupt.

**Long Syntax:** ESC.040 ESCON DD received an Unexpected Interrupt notification from slot *slot* ESCON adapter.

**Description:** ESCON adapter had an unexpected interrupt. If the problem persists, contact Software Support.

---

**ESC.041**

**Level:** UI-ERROR

**Short Syntax:** ESC.041 ESCON adapter in slot *slot* had a serial engine failure, dump is *log\_stat*.

**Long Syntax:** ESC.041 ESCON DD received a Serial Engine Failure notification from slot *slot* ESCON adapter, dump is *log\_stat*.

**Description:** The ESCON adapter is reporting that it had a serial engine failure. The

adapter will be automatically restarted. Diagnostics will be invoked if the adapter fails to restart.

**Cause:** This may be the result of disconnecting the ESCON fiber from the ESCON adapter and then reconnecting it.

**Action:** If the adapter fails to restart, contact Software Support.

---

#### ESC.042

**Level:** UI-ERROR

**Short Syntax:** ESC.042 Slot *slot* ESCON adapter microcode aborted with rc=0x *rc*.

**Long Syntax:** ESC.042 ESCON DD received a Microcode Aborted notification from slot *slot* ESCON adapter, rc=0x *rc*.

**Description:** The ESCON adapter is reporting that the microcode aborted. The adapter will be automatically restarted. Diagnostics will be invoked if the adapter fails to restart.

**Cause:** This may be the result of disconnecting the ESCON fiber from the ESCON adapter and then reconnecting it.

**Action:** If the adapter fails to restart, contact Software Support.

---

#### ESC.043

**Level:** C-INFO

**Short Syntax:** ESC.043 ESCON DD rcvd Logical Path Estbl notif from slot *slot*, link addr=0x *link*, LPAR=0x *lpar*, cu-num=0x *cu\_num*.

**Long Syntax:** ESC.043 ESCON DD received a Logical Path Established notification from slot *slot* ESCON adapter, link addr=0x *link*, LPAR=0x *lpar*, cu-num=0x *cu\_num*.

**Description:** The ESCON adapter has made a connection to the host via one of the configured subchannel paths.

---

#### ESC.044

**Level:** UI-ERROR

**Short Syntax:** ESC.044 ESCON adapter in slot *slot* had a POST error, error = 0x *error*.

**Long Syntax:** ESC.044 ESCON adapter in slot *slot* has a POST error, error = 0x *error*.

**Description:** The ESCON adapter had a POST error. The adapter will be automatically restarted. Diagnostics will be invoked if the adapter fails to restart.

**Action:** If adapter fails to restart, contact Software Support.

---

#### ESC.045

**Level:** UI-ERROR

**Short Syntax:** ESC.045 ESCON adapter in slot *slot* had a POST error, CBSP value=0x *error*.

**Long Syntax:** ESC.045 ESCON adapter in slot *slot* had a POST error, CBSP value=0x *error*.

**Description:** The ESCON adapter had a POST error. The adapter will be automatically restarted. Diagnostics will be invoked if the adapter fails to restart.

**Action:** If adapter fails to restart, contact Software Support.

---

**ESC.046****Level:** UI-ERROR**Short Syntax:** ESC.046 ESCON adapter in slot *slot* did not complete POST.**Long Syntax:** ESC.046 ESCON adapter in slot *slot* did not complete POST.**Description:** The ESCON adapter did not complete POST. The adapter will be automatically restarted. Diagnostics will be invoked if the adapter fails to restart.**Action:** If the adapter passes diagnostics but fails to restart, contact Software Support.

---

**ESC.047****Level:** UI-ERROR**Short Syntax:** ESC.047 ESCON adapter in slot *slot* had a PrePOST error = 0x *error*.**Long Syntax:** ESC.047 ESCON adapter in slot *slot* had a PrePOST error = 0x *error*.**Description:** The ESCON adapter had a PrePOST error. The adapter will be automatically restarted. Diagnostics will be invoked if the adapter fails to restart.**Action:** If the adapter does not restart, contact Software Support.

---

**ESC.048****Level:** UI-ERROR**Short Syntax:** ESC.048 Slot *slot* does not contain an ESCON card, identifier = *id*.**Long Syntax:** ESC.048 Slot *slot* does not contain an ESCON card, identifier = *id*.**Description:** The slot does not contain an ESCON card and the software has been configured for an ESCON adapter in that slot.**Action:** Correct the configuration. If the problem occurs after reconfiguration, contact Software Support.

---

**ESC.049****Level:** UI-ERROR**Short Syntax:** ESC.049 Slot *slot* ESCON Adapter timed-out during initialization, cmd=0x *cmd*.**Long Syntax:** ESC.049 Slot *slot* ESCON Adapter timed-out during initialization, cmd=0x *cmd*.**Description:** The adapter will be automatically restarted.**Action:** If the adapter does not restart, contact Software Support.

---

**ESC.050****Level:** UI-ERROR**Short Syntax:** ESC.050 Slot *slot* ESCON Control Unit table did not load correctly, rc=0x *rc*, tbl=0x *tbl\_num*.**Long Syntax:** ESC.050 Slot *slot* ESCON Control Unit table did not load correctly, rc=0x *rc*, tbl=0x *tbl\_num*.**Description:** The ESCON adapter cannot start properly without these tables. The adapter will be automatically restarted.**Action:** If the adapter does not restart, contact Software Support.

---

**ESC.051****Level:** UI-ERROR**Short Syntax:** ESC.051 ESCON DD could not obtain a Control Buffer from slot *slot* adapter.**Long Syntax:** ESC.051 ESCON DD could not obtain a Control Buffer from adapter in slot *slot*.**Description:** The device driver requires a buffer from the adapter. If the adapter cannot provide the buffer then the adapter is not functioning properly. The adapter will be restarted automatically.**Action:** If the problem persists, contact Software Support.

---

**ESC.052****Level:** U-INFO**Short Syntax:** ESC.052 ESCON DD encountered an internal error for slot *slot*. Identifier = *id*.**Long Syntax:** ESC.052 ESCON DD encountered an internal error for slot *slot*. Identifier = *id*.**Description:** The ESCON device driver has encountered a condition that it cannot handle properly.**Action:** If the problem persists, contact Software Support.

---

**ESC.053****Level:** UI-ERROR**Short Syntax:** ESC.053 ESCON DD detected a CRC error in CU Table *tbl\_num* for slot *slot*.**Long Syntax:** ESC.053 ESCON DD detected a CRC error in CU Table *tbl\_num* for slot *slot*.**Description:** The adapter will be restarted automatically.**Action:** If the problem persists, contact Software Support.

---

**ESC.054****Level:** UI-ERROR**Short Syntax:** ESC.054 ESCON DD could not obtain system memory; slot=0x *slot*, identifier= *id*.**Long Syntax:** ESC.054 ESCON DD could not obtain system memory; slot=0x *slot*, identifier= *id*.**Description:** If this error occurred during initialization, the adapter will be restarted.**Action:** If the problem persists, contact Software Support.

---

**ESC.055****Level:** UI-ERROR**Short Syntax:** ESC.055 ESCON DD could not open dump file on harddrive. Dump not available for slot *slot* adapter.**Long Syntax:** ESC.055 ESCON DD could not open the dump file on the harddrive. The dump is not available for slot *slot* adapter**Description:** The device driver attempted to open a file on the harddrive but was unsuccessful. The dump of the ESCON adapter is not available.

**Action:** If problems with the adapter persist, contact Software Support.

---

#### ESC.056

**Level:** UI-ERROR

**Short Syntax:** ESC.056 ESCON DD could not dump all slot *slot* ESCON adapter data to the dump file.

**Long Syntax:** ESC.056 ESCON DD could not dump all of the slot *slot* ESCON adapter data to the dump file on the harddrive.

**Description:** The device driver attempted to dump the ESCON adapter data to a file on the harddrive. The dump may be partially available in c:\SYS0\ESCONx.DMP, where x is the slot number.

**Action:** Contact Software Support.

---

#### ESC.057

**Level:** C-INFO

**Short Syntax:** ESC.057 ESCON DD received a reset subchannel notif for subchannel 0x *sc*, slot= *slot*.

**Long Syntax:** ESC.057 ESCON DD received a reset subchannel notification for subchannel 0x *sc*, slot= *slot*.

**Description:** The device driver received a reset subchannel notification.

---

#### ESC.058

**Level:** C-INFO

**Short Syntax:** ESC.058 Incorrect subchannel configuration detected for slot *slot* ESCON adapter.

**Long Syntax:** ESC.058 Incorrect subchannel configuration detected for slot *slot* ESCON adapter.

**Description:** The device driver has detected that a subchannel configuration is incorrect. Correctly configured subchannels should not be affected by this problem.

**Action:** Correct the configuration.

---

#### ESC.059

**Level:** UI-ERROR

**Short Syntax:** ESC.059 ESCON DD could not obtain a Command FIFO entry from slot *slot* adapter.

**Long Syntax:** ESC.059 ESCON DD could not obtain a Command FIFO entry from adapter in slot *slot*.

**Description:** The device driver requires a Command FIFO entry in order to communicate with the adapter. If the adapter cannot obtain an entry during initialization, the adapter will be restarted. If the adapter cannot obtain an entry at any other time, the internal software will attempt to recover.

**Action:** If the problem persists, contact Software Support.

---

**ESC.060****Level:** P-TRACE**Short Syntax:** ESC.060 ESCON DD sending frame from slot= *slot*,, subchan= *subchan*,, LT= *lantype*,, LN= *lannum*, to base net.**Long Syntax:** ESC.060 ESCON DD rcvd frame from slot *slot*, ESCON, subchan= *subchan*,, LanType= *lantype*,, and LanNum= *lannum*; sending it to base net.**Description:** A frame was received by the channel and was sent to the ESCON base net handler.

---

**ESC.061****Level:** P-TRACE**Short Syntax:** ESC.061 ESCON DD rcvd frame from net handler for slot= *slot*,, subchan= *subchan*,, LT= *lantype*,, LN= *lannum*,,PDU-hdr= *pdu\_len***Long Syntax:** ESC.061 ESCON DD received a frame from a net handler destined for slot *slot*, ESCON adapter, subchan= *subchan*,, LanType= *lantype*,, and LanNum= *lannum*,, PDU-header len= *pdu\_len*.**Description:** An ESCON-related nethandler sent the ESCON DD a frame to transmit.

---

**ESC.062****Level:** P-TRACE**Short Syntax:** ESC.062 ESCON DD rcvd *cmd*, *cmd* from net handler for slot *slot* ESCON.**Long Syntax:** ESC.062 ESCON DD received *cmd*, command from net handler for slot *slot* ESCON adapter.**Description:** An ESCON-related net handler sent the ESCON DD a command.

---

**ESC.063****Level:** P-TRACE**Short Syntax:** ESC.063 ESCON DD rcvd *cmd*, *cmd* from nethandler for slot *slot*, ESCON, subchan= *subchan*.**Long Syntax:** ESC.063 ESCON DD received *cmd*, command from a nethandler for slot *slot*, ESCON adapter, subchan= *subchan*.**Description:** An ESCON-related net handler sent the ESCON DD a command.

---

**ESC.064****Level:** P-TRACE**Short Syntax:** ESC.064 ESCON DD sent *notif*, *notif* for slot *slot*, ESCON, subchan= *subchan*,, LT= *lantype*,, LN= *lannum*, to nethandler.**Long Syntax:** ESC.064 ESCON DD sent *notif*, *notif* for slot *slot*, ESCON adapter, subchan= *subchan*,, LT= *lantype*,, LN= *lannum*, to nethandler.**Description:** The ESCON device driver sent a notification to an ESCON-related net handler



---

**ESC.65****Level:** U-INFO**Short Syntax:** ESCON adapter ran out of rcv buffers, LCS frame discarded, slot=*slot*, local sc=*slot*\r\n**Long Syntax:** ESCON adapter ran out of receive buffers and discarded an LCS frame; slot=*slot* local subchan=*subchan*.**Description:** The ESCON adapter is reporting that it discarded an LCS frame because it could not obtain a receive buffer.**Action:** Typically, no action is required. If the problem persists, increase the number of receive buffers for this ESCON adapter.

---

**ESC.66****Level:** UI-ERROR**Short Syntax:** ESCON adapter ran out of rcv buffers, LSA frame discarded, slot=*slot*, local sc=*slot*\r\n**Long Syntax:** ESCON adapter ran out of receive buffers and discarded an LSA frame; slot=*slot* local subchan=*subchan*.**Description:** The ESCON adapter is reporting that it discarded an LSA frame because it could not obtain a receive buffer.**Action:** Increase the number of receive buffers for this ESCON adapter.

---

**ESC.67****Level:** U-INFO**Short Syntax:** ESCON adapter ran out of rcv buffers, MPC+ frame discarded, slot=*slot*, local sc=*slot*\r\n**Long Syntax:** ESCON adapter ran out of receive buffers and discarded an MPC+ frame; slot=*slot* local subchan=*subchan*.**Description:** The ESCON adapter is reporting that it discarded an MPC+ frame because it could not obtain a receive buffer.**Action:** Typically, no action is required. If the problem persists, increase the number of receive buffers for this ESCON adapter.

---

**Level:** Panic**Short Syntax:** escnomem: ESCON handler no memory**Description:** An ESCON handler cannot allocate memory for control block(s).**Action:** Contact customer service.

---

**Level:** Panic**Short Syntax:** escnsram: ESCON SRAM not found**Description:** The SRAM record for an ESCON handler could not be found.**Action:** Contact customer service.

---

**Level:** Panic

**Short Syntax:** escbprt: bad prot init

**Description:** An unsupported Network Layer protocol tried to initialize an ESCON handler.

**Action:** Contact customer service.

---

**Level:** Panic

**Short Syntax:** escdreg: virt net already reg

**Description:** An ESCON virtual net handler has already registered with the base.

**Action:** Contact customer service.

---

**Level:** Panic

**Short Syntax:** escbreq: bad xmit rqst

**Description:** An unsupported protocol packet was given to the ESCON handler for transmission.

**Action:** Contact customer service.

---

**Level:** Panic

**Short Syntax:** escnosub: subch not found

**Description:** The requested logical path and device address was not found in the ESCON base handler subchannel table.

**Action:** Contact customer service.

---

**Level:** Panic

**Short Syntax:** escbcall: bad call to routine.

**Description:** An invalid call was made to a routine.

**Action:** Contact customer service.

---

## LCS Virtual Network Interface (LCS) Messages

This section describes LCS Virtual Network Interface (LCS) messages. For information on message content and how to use the message, refer to the "Introduction" in *ELS Messages*.

---

**LCS.001****Level:** P-TRACE**Short Syntax:** LCS.001 brd rcv unkwn typ *packet\_type* *source\_Ethernet\_address* -> *destination\_Ethernet\_address* nt *network***Long Syntax:** LCS.001 broadcast packet received with unknown Ethernet type *packet\_type* from host *source\_Ethernet\_address* to *destination\_Ethernet\_address* network *network***Description:** A broadcast packet was received with an unknown or unsupported Ethernet type field.

---

**LCS.002****Level:** UE-ERROR**Short Syntax:** LCS.002 rcv unkwn typ *packet\_type* *source\_Ethernet\_address* -> *destination\_Ethernet\_address* nt *network***Long Syntax:** LCS.002 packet received with unknown Ethernet type field *packet\_type* from *source\_Ethernet\_address* to *destination\_Ethernet\_address* network *network***Description:** A non-broadcast packet was received with an unknown or unsupported Ethernet type field.

---

**LCS.003****Level:** P-TRACE**Short Syntax:** LCS.003 brd 802.3 bd ln *actual\_length* *claimed\_length* *source\_Ethernet\_address* -> *destination\_Ethernet\_address* nt *network***Long Syntax:** LCS.003 broadcast packet received with a bad 802.3 length field actual *actual\_length* claimed *claimed\_length* from *source\_Ethernet\_address* to *destination\_Ethernet\_address* network *network***Description:** A broadcast packet was received with a type field that indicated 802.3 but was shorter than data length claimed in the 802.3 header.

---

**LCS.004****Level:** UE-ERROR**Short Syntax:** LCS.004 802.3 bd ln *actual\_length* *claimed\_length* *source\_Ethernet\_address* -> *destination\_Ethernet\_address* nt *network***Long Syntax:** LCS.004 packet received with a bad 802.3 length field actual *actual\_length* claimed *claimed\_length* from *source\_Ethernet\_address* to *destination\_Ethernet\_address* network *network***Description:** A non-broadcast packet was received with a type field that indicated 802.3 but was shorter than data length claimed in the 802.3 header.

---

**LCS.005****Level:** UI\_ERROR**Short Syntax:** LCS.005 MAC frm typ *mac\_frametype* unex from *hardware\_address* nt *network***Long Syntax:** LCS.005 MAC frame type *mac\_frametype* unexpected from *hardware\_address* network *network***Description:** The handler received a frame with an unexpected frame type.

---

**LCS.006**

**Level:** C-INFO

**Short Syntax:** LCS.006 LLC unk SAP *DSAP source\_Ethernet\_address -> destination\_Ethernet\_address nt network*

**Long Syntax:** LCS.006 802.2 LLC packet received with unknown DSAP *DSAP* from host *source\_Ethernet\_address* to *destination\_Ethernet\_address network network*

**Description:** An 802.2 LLC packet was received from the network with an inactive (unrecognized) DSAP.

---

**LCS.007**

**Level:** C-INFO

**Short Syntax:** LCS.007 LLC nt typ 1 *LLC\_control\_type nt network*

**Long Syntax:** LCS.007 802.2 LLC packet received, not Type 1 *LLC\_control\_type network network*

**Description:** A packet was received from the network that had an LLC but was not a Type 1 LLC.

---

**LCS.008**

**Level:** C-INFO

**Short Syntax:** LCS.008 LLC RSP *LLC\_SSAP nt network*

**Long Syntax:** LCS.008 LLC RESPONSE packet received *LLC\_SSAP network network*

**Description:** An LLC response was received from the network.

---

**LCS.009**

**Level:** C-INFO

**Short Syntax:** LCS.009 LLC XID *LLC\_SSAP nt network*

**Long Syntax:** LCS.009 LLC XID packet received *LLC\_SSAP network network*

**Description:** An LLC XID packet was received from the network.

---

**LCS.010**

**Level:** C-INFO

**Short Syntax:** LCS.010 LLC TEST *LLC\_SSAP nt network*

**Long Syntax:** LCS.010 LLC TEST packet received *LLC\_SSAP network network*

**Description:** An LLC TEST packet was received from the network.

---

**LCS.011**

**Level:** U-INFO

**Short Syntax:** LCS.011 unrec ctl *LLC\_control\_field nt network*

**Long Syntax:** LCS.011 packet received with unrecognized control field *LLC\_control\_field network network*

**Description:** A packet was received from the network that had an illegal control field or UI.

---

**LCS.012**

**Level:** ALWAYS

**Short Syntax:** LCS.012 LCS Eth nt *network* set to *eth\_vers*

**Long Syntax:** LCS.012 LCS Ethernet network *network* set to Ethernet *eth\_vers*

**Description:** An ARP frame in the indicated format has been received. The LCS net is set to operate using the indicated Ethernet version.

---

**LCS.013**

**Level:** UE-ERROR

**Short Syntax:** LCS.013 ARP rcv bd hdw type on nt *network* *rec\_hdw\_type* *exp\_hdw\_type* *rec\_hdw\_len* *exp\_hdw\_len*

**Long Syntax:** LCS.013 ARP packet received with bad hardware information on network *network*: type received *rec\_hdw\_type* expected *exp\_hdw\_type*, length received *rec\_hdw\_len* expected *exp\_hdw\_len*

**Description:** An ARP packet was received in which either the hardware type or hardware length did not match what was expected.

---

**LCS.014**

**Level:** UE-ERROR

**Short Syntax:** LCS.014 ARP rcv bd prot type on nt *network* *rec\_prot\_type* *exp\_prot\_type* *rec\_prot\_len* *exp\_prot\_len*

**Long Syntax:** LCS.014 ARP packet received with bad protocol information on network *network*: type received *rec\_prot\_type* expected *exp\_prot\_type*, length received *rec\_prot\_len* expected *exp\_prot\_len*

**Description:** An ARP packet was received in which either the protocol type or protocol length did not match what was expected.

---

**LCS.015**

**Level:** UE-ERROR

**Short Syntax:** LCS.015 ARP rcv bd dest addr *dest\_address* not *local\_addr* on nt *network*

**Long Syntax:** LCS.015 ARP packet received for destination address *dest\_address* not *local\_addr* on network *network*

**Description:** An ARP packet was received in which the destination IP address did not match the local IP address.

---

**LCS.016**

**Level:** UE-ERROR

**Short Syntax:** LCS.016 ARP rcv bd type *arp\_type* on nt *network*

**Long Syntax:** LCS.016 ARP packet received with unknown type *arp\_type* on network *network*

**Description:** An ARP packet was received which was not a ARP request.

---

**LCS.017**

**Level:** UI-ERROR

**Short Syntax:** LCS.017 LCS frm rcvd when net not op on nt *network*

**Long Syntax:** LCS.017 LCS frame received when network *network* is not operational

**Description:** An LCS frame was received while the network was not enabled for input

---

**LCS.018**

**Level:** P-TRACE

**Short Syntax:** LCS.018 ARP rsp sent on nt *network*

**Long Syntax:** LCS.018 An ARP response was sent to the host on network *network*

**Description:** A ARP response was sent.

---

**LCS.019**

**Level:** P-TRACE

**Short Syntax:** LCS.019 Eth frm rcvd on nt *network*

**Long Syntax:** LCS.019 An Ethernet frame was received on network *network*

**Description:** An Ethernet frame was received.

---

**LCS.020**

**Level:** P-TRACE

**Short Syntax:** LCS.020 Tok frm rcvd on nt *network*

**Long Syntax:** LCS.020 A Token-Ring frame was received on network *network*

**Description:** A Token-Ring frame was received.

---

**LCS.021**

**Level:** C-INFO

**Short Syntax:** LCS.021 nt *network* set to IP *IP\_address*

**Long Syntax:** LCS.021 network *network* set to IP address *IP\_address*

**Description:** The net handler has been set to an IP address.

---

**LCS.022**

**Level:** P-TRACE

**Short Syntax:** LCS.022 IP frm sent on nt *network*

**Long Syntax:** LCS.022 An IP frame was sent on network *network*

**Description:** An IP frame was sent.

---

## LSA Virtual Network Interface (LSA) Messages

This section describes LSA Virtual Network Interface (LSA) messages. For information on message content and how to use the message, refer to the "Introduction" in *ELS Messages*.

---

**LSA.001****Level:** CI-ERROR**Short Syntax:** LSA.001 LSA id\_check error *error\_code*, (nt *network*)**Long Syntax:** LSA.001 LSA id\_check error *error\_code*, (network *network*)**Description:** There is no corresponding u\_cep\_id or u\_sap\_id to send a response to.

---

**LSA.002****Level:** CI-ERROR**Short Syntax:** LSA.002 LSA Error, no mem alloc for SAP CB, (nt *network*)**Long Syntax:** LSA.002 LSA Error, unable to allocate memory for SAP CB, (network *network*)**Description:** Unable to allocate memory for a SAP CB.

---

**LSA.003****Level:** CI-ERROR**Short Syntax:** LSA.003 LSA Error, no room to alloc mem for LSCB *sap\_cb\_ptr*, (nt *network*)**Long Syntax:** LSA.003 LSA Error, no room available to allocate memory for LSCB *sap\_cb\_ptr*, (network *network*)**Description:** No room in table to allocate an additional LSCB.

---

**LSA.004****Level:** CI-ERROR**Short Syntax:** LSA.004 LSA dl\_close\_sap error *llc\_rc* from LLC, (nt *network*)**Long Syntax:** LSA.004 LSA dl\_close\_sap error *llc\_rc* from LLC, (network *network*)**Description:** LLC detected an error when LSA attempted to close a SAP.

---

**LSA.005****Level:** CI-ERROR**Short Syntax:** LSA.005 LSA dl\_close\_station error *llc\_rc* from LLC, (nt *network*)**Long Syntax:** LSA.005 LSA dl\_close\_station error *llc\_rc* from LLC, (network *network*)**Description:** LLC detected an error when LSA attempted to close a link station.

---

**LSA.006****Level:** CI-ERROR**Short Syntax:** LSA.006 LSA dl\_data\_request error *llc\_rc* from LLC, (nt *network*)**Long Syntax:** LSA.006 LSA dl\_data\_request error *llc\_rc* from LLC, (network *network*)**Description:** LLC detected an error when LSA attempted to send a Type2 data frame.

---

**LSA.007****Level:** CI-ERROR**Short Syntax:** LSA.007 LSA header\_check error *error\_code*, (nt *network*)**Long Syntax:** LSA.007 LSA header\_check error *error\_code*, (network *network*)**Description:** An error was found while checking the header of an inbound LSA primitive.

---

**LSA.008****Level:** CE-ERROR**Short Syntax:** LSA.008 LSA stn *p\_cep\_id* on SAP *sap\_value* terminated with rc *vtamrc*, (nt *network*)**Long Syntax:** LSA.008 LSA closing link station *p\_cep\_id* on SAP *sap\_value* with rc *vtamrc*, (network *network*)**Description:** LSA has closed a link station on a VTAM SAP for this network interface.

---

**LSA.009****Level:** C-INFO**Short Syntax:** LSA.009 LSA disabling int for VTAM host user *host\_user*, (nt *network*)**Long Syntax:** LSA.009 LSA disabling interface for VTAM host user *host\_user*, (network *network*)**Description:** LSA has disabled a VTAM user connection because the subchannel is offline.

---

**LSA.010****Level:** C-INFO**Short Syntax:** LSA.010 LSA closing SAP *sap\_value*, (nt *network*)**Long Syntax:** LSA.010 LSA closing SAP *sap\_value*, (network *network*)**Description:** LSA has closed a VTAM SAP for this network interface.

---

**LSA.011****Level:** C-INFO**Short Syntax:** LSA.011 LSA stn *p\_cep\_id* on SAP *sap\_value* closed by VTAM, (nt *network*)**Long Syntax:** LSA.011 LSA link station *p\_cep\_id* on SAP *sap\_value* closed by VTAM, (network *network*)**Description:** LSA has closed a link station on a VTAM SAP for this network interface.

---

**LSA.012****Level:** C-INFO**Short Syntax:** LSA.012 LSA stn *p\_cep\_id* on SAP *sap\_value* terminated with rc *vtamrc*, (nt *network*)**Long Syntax:** LSA.012 LSA closing link station *p\_cep\_id* on SAP *sap\_value* with rc *vtamrc*, (network *network*)**Description:** LSA has closed a link station on a VTAM SAP for this network interface.



---

**LSA.013****Level:** CI-ERROR**Short Syntax:** LSA.013 LSA Error, invalid p\_cep\_id or p\_sap\_id *cookie*, (nt *network*)**Long Syntax:** LSA.013 LSA Error, invalid p\_cep\_id or p\_sap\_id *cookie*, (network *network*)**Description:** An LLC event or data frame was received with an invalid "cookie".

---

**LSA.014****Level:** CI-ERROR**Short Syntax:** LSA.014 LSA Error, event rcvd from wrong LAN, (nt *network*)**Long Syntax:** LSA.014 LSA Error, event received from wrong LAN, (network *network*)**Description:** An LLC event or data frame was received from the wrong LAN.

---

**LSA.015****Level:** CI-ERROR**Short Syntax:** LSA.015 LSA Error, LLC event *event\_type* received in state *vlan\_status*, (nt *network*)**Long Syntax:** LSA.015 LSA Error, LLC event *event\_type* received in state *vlan\_status*, (network *network*)**Description:** LLC event occurred before LSA virtual interface was online.

---

**LSA.016****Level:** CI-ERROR**Short Syntax:** LSA.016 LSA Error, SABME rcvd for statn *station* in state *status*, (nt *network*)**Long Syntax:** LSA.016 LSA Error, SABME received for station *station* in state *status*, (network *network*)**Description:** SABME received on connected station.

---

**LSA.017****Level:** CI-ERROR**Short Syntax:** LSA.017 LSA Error, unxpctd Conn Confirm rcvd for stn *station* in state *status*, (nt *network*)**Long Syntax:** LSA.017 LSA Error, unexpected Connect Confirm received for link station *station* in link state *status*, (network *network*)**Description:** An unexpected Connect Confirm was received from LLC.

---

**LSA.018****Level:** CI-ERROR**Short Syntax:** LSA.018 LSA Error, unable to allocate LSCB for SAP *sap\_id*, (nt *network*)**Long Syntax:** LSA.018 LSA Error, unable to allocate LSCB for SAP *sap\_id*, (network *network*)**Description:** Unable to find a free LSCB for this SAP.

---

**LSA.019**

**Level:** CI-ERROR

**Short Syntax:** LSA.019 LSA Error, invalid route info len *route\_inf\_len* rcvd, (nt *network*)

**Long Syntax:** LSA.019 LSA Error, invalid routing information length *route\_inf\_len* received, (network *network*)

**Description:** Invalid routing information length received.

---

**LSA.020**

**Level:** CI-ERROR

**Short Syntax:** LSA.020 LSA Error, event type *event\_type*, invalid cause code *cause\_code* rcvd, (nt *network*)

**Long Syntax:** LSA.020 LSA Error, event type *event\_type*, unexpected cause code *cause\_code* received, (network *network*)

**Description:** Invalid cause code received.

---

**LSA.021**

**Level:** CI-ERROR

**Short Syntax:** LSA.021 LSA Error, unexpected event type *event\_type* rcvd, (nt *network*)

**Long Syntax:** LSA.021 LSA Error, unexpected event type *event\_type* received, (network *network*)

**Description:** Unknown event type received from LLC.

---

**LSA.022**

**Level:** CE-ERROR

**Short Syntax:** LSA.022 LSA Error, invalid LAN type *lan\_type* or LAN num *lan\_num*, (nt *network*)

**Long Syntax:** LSA.022 LSA Error, invalid LAN type *lan\_type* or LAN number *lan\_num*, (network *network*)

**Description:** LAN type or LAN number is invalid.

---

**LSA.023**

**Level:** CI-ERROR

**Short Syntax:** LSA.023 LSA Error, virt adapt not init, stat is *virt\_adap\_stat*, (nt *network*)

**Long Syntax:** LSA.023 LSA Error, virtual adapter not initialized, status is *virt\_adap\_stat*, (network *network*)

**Description:** The virtual adapter status is not ENABLED.

---

**LSA.024**

**Level:** CI-ERROR

**Short Syntax:** LSA.024 LSA Error, frame rcvd with unknwn id *identifier*, (nt *network*)

**Long Syntax:** LSA.024 LSA Error, frame received with unknown identifier *identifier*, (network *network*)

**Description:** A frame was received with an unknown p\_sap\_id or p\_cep\_id.

---

**LSA.025****Level:** CI-ERROR**Short Syntax:** LSA.025 LSA Error, cntrlr len *controller\_len* should be *t2\_len*, (nt *network*)**Long Syntax:** LSA.025 LSA Error, controller length *controller\_len* should be *t2\_len*, (network *network*)**Description:** The controller length is invalid.

---

**LSA.026****Level:** CI-ERROR**Short Syntax:** LSA.026 LSA Error, XID poll/final *cmd\_resp* or *cmd/resp poll\_final* error, (nt *network*)**Long Syntax:** LSA.026 LSA Error, XID poll/final *cmd\_resp* or command/response field value *poll\_final* is incorrect, (network *network*)**Description:** The poll/final field contains an invalid value or incorrect state, or the cmd/resp field is invalid.

---

**LSA.027****Level:** CI-ERROR**Short Syntax:** LSA.027 LSA Error, invalid routing info len *route\_info\_len*, (nt *network*)**Long Syntax:** LSA.027 LSA Error, invalid routing information length of *route\_info\_len*, (network *network*)**Description:** The routing information length is invalid.

---

**LSA.028****Level:** CI-ERROR**Short Syntax:** LSA.028 LSA Error, frame len *frame\_size* exceeded max *frame\_max*, (nt *network*)**Long Syntax:** LSA.028 LSA Error, frame length of *frame\_size* exceeded maximum of *frame\_max*, (network *network*)**Description:** The frame size exceeded the maximum.

---

**LSA.029****Level:** CI-ERROR**Short Syntax:** LSA.029 LSA Error, invalid SSAP *ssap* for Test/XID, (nt *network*)**Long Syntax:** LSA.029 LSA Error, invalid SSAP *ssap* for Test/XID, (network *network*)**Description:** The Source SAP is invalid for a Test/XID.

---

**LSA.030****Level:** CI-ERROR**Short Syntax:** LSA.030 LSA Error, invalid SAP CB ptr *sap\_cb*, (nt *network*)**Long Syntax:** LSA.030 LSA Error, invalid SAP CB pointer *sap\_cb*, (network *network*)**Description:** The SAP CB pointer is invalid.

---

**LSA.031****Level:** CI-ERROR**Short Syntax:** LSA.031 LSA Error, unexpected ret code 0x *ret\_code* from LLC call to *func\_name*, (nt *network*)**Long Syntax:** LSA.031 LSA Error, unexpected return code 0x *ret\_code* from LLC call to *func\_name*, (network *network*)**Description:** LLC has returned an error code to the LSA net handler.

---

**LSA.032****Level:** CI-ERROR**Short Syntax:** LSA.032 LSA Error, prim type *primitive* vtam code *vtam\_code*, parm *parm* (nt *network*)**Long Syntax:** LSA.032 LSA Error, primitive type *primitive* vtam code *vtam\_code*, parameter *parm* (network *network*)**Description:** An error occurred processing the VTAM request/response. The specified parameter was responsible.

---

**LSA.033****Level:** C-INFO**Short Syntax:** LSA.033 LSA enabling int for VTAM host user *host\_user*, (nt *network*)**Long Syntax:** LSA.033 LSA enabling interface for VTAM host user *host\_user*, (network *network*)**Description:** LSA has enabled a VTAM user connection.

---

**LSA.034****Level:** C-INFO**Short Syntax:** LSA.034 LSA opening SAP *sap\_value*, p\_sap\_id *p\_sap\_id* (nt *network*)**Long Syntax:** LSA.034 LSA opening SAP *sap\_value*, p\_sap\_id *p\_sap\_id* (network *network*)**Description:** LSA has opened a VTAM SAP for this network interface.

---

**LSA.035****Level:** C-INFO**Short Syntax:** LSA.035 LSA stn *p\_cep\_id* on SAP *sap\_value* opened by VTAM, (nt *network*)**Long Syntax:** LSA.035 LSA link station *p\_cep\_id* on SAP *sap\_value* opened by VTAM, (network *network*)**Description:** LSA has opened a link station on a VTAM SAP for this network interface.

---

**LSA.036****Level:** CI-ERROR**Short Syntax:** LSA.036 LSA Event, prim type *primitive* vtam code *vtam\_code*, (nt *network*)**Long Syntax:** LSA.036 LSA Event, primitive type *primitive* vtam code *vtam\_code*, (network *network*)**Description:** An non-error event occurred processing the VTAM request/response.

---

**LSA.037****Level:** CI-ERROR**Short Syntax:** LSA.037 LSA Error, MAC adap not enabled, (nt *network*)**Long Syntax:** LSA.037 LSA Error, MAC adapter is not enabled, (network *network*)**Description:** The MAC adapter is not enabled.

---

**LSA.038****Level:** CI-ERROR**Short Syntax:** LSA.038 LSA Error, out of host user blocks, (nt *network*)**Long Syntax:** LSA.038 LSA Error, out of host user blocks, (network *network*)**Description:** There are no more host user blocks.

---

**LSA.039****Level:** CI-ERROR**Short Syntax:** LSA.039 LSA Error, unknwn or unexpect req/resp *primitive* rcvd, (nt *network*)**Long Syntax:** LSA.039 LSA Error, unknown or unexpected request/response *primitive* received, (network *network*)**Description:** An unknown or unexpected primitive was received.

---

**LSA.040****Level:** CI-ERROR**Short Syntax:** LSA.040 LSA Error, invalid req/resp *primitive* for statn *station\_status* stat *network/* )**Long Syntax:** LSA.040 LSA Error, invalid request/response *primitive* for station *station\_status* in status *network/* )**Description:** The req/response is invalid for this stations status.

---

**LSA.041****Level:** CI-ERROR**Short Syntax:** LSA.041 LSA dl\_open\_station error 0x *llc\_rc* from LLC, (nt *network*)**Long Syntax:** LSA.041 LSA dl\_open\_station error 0x *llc\_rc* from LLC, (network *network*)**Description:** LLC detected an error when LSA attempted to open a link station.

---

**LSA.042****Level:** C-INFO**Short Syntax:** LSA.042 LSA stn *p\_cep\_id* on SAP *sap\_value* conn est, (nt *network*)**Long Syntax:** LSA.042 LSA link station *p\_cep\_id* on SAP *sap\_value* connection established, (network *network*)**Description:** LSA has established an LLC connection with a remote link station.

---

**LSA.043**

**Level:** C-INFO

**Short Syntax:** LSA.043 LSA stn *p\_cep\_id* on SAP *sap\_value* conn rej by *rej\_end*, (nt *network*)

**Long Syntax:** LSA.043 LSA link station *p\_cep\_id* on SAP *sap\_value* connection rejected by *rej\_end*, (network *network*)

**Description:** An LLC connection to a remote link station was rejected.

---

**LSA.044**

**Level:** C-INFO

**Short Syntax:** LSA.044 LSA net *netnum* rcvd netup from net *lan\_netnum* (nt *network*)

**Long Syntax:** LSA.044 LSA net *netnum* received netup from net *lan\_netnum* (network *network*)

**Description:** LSA net handler received netup from attached downstream LAN.

---

**LSA.045**

**Level:** C-INFO

**Short Syntax:** LSA.045 LSA net *netnum* MAC addr *macaddr* set (nt *network*)

**Long Syntax:** LSA.045 LSA net *netnum* MAC address set to *macaddr* (network *network*)

**Description:** LSA net handler received netup from attached downstream LAN.

---

**LSA.046**

**Level:** P-TRACE

**Short Syntax:** LSA.046 LSA user data to base net handler (nt *network*)

**Long Syntax:** LSA.046 LSA user data sent to the base net handler (network *network*)

**Description:** The LSA net handler sent user data to the base net handler.

---

**LSA.047**

**Level:** P-TRACE

**Short Syntax:** LSA.047 LSA user data from base net handler (nt *network*)

**Long Syntax:** LSA.047 LSA user data received from the base net handler (network *network*)

**Description:** The LSA net handler received user data from the base net handler.

---

**LSA.048**

**Level:** P-TRACE

**Short Syntax:** LSA.048 LSA prim *prim\_code* to base net handler (nt *network*)

**Long Syntax:** LSA.048 LSA primitive *prim\_code* sent to the base net handler (network *network*)

**Description:** The LSA net handler sent data to the base net handler. This data is primitives that contain primitives use by LSA to run the connection to the host; not user data running over the connection.

---

**LSA.049****Level:** P-TRACE**Short Syntax:** LSA.049 LSA prim *prim\_code* from base net handler (nt *network*)**Long Syntax:** LSA.049 LSA primitive *prim\_code* received from the base net handler (network *network*)**Description:** The LSA net handler received data from the base net handler. This data is primitives that contain primitives use by LSA to run the connection to the host; not user data running over the connection.

---

**LSA.050****Level:** C-INFO**Short Syntax:** LSA.050 *in\_out* flow *on\_off* LSA stn *p\_cep\_id* on SAP *sap\_value*, (nt *network*)**Long Syntax:** LSA.050 *in\_out* flow turned *on\_off* for LSA link station *p\_cep\_id* on SAP *sap\_value*, (network *network*)**Description:** VTAM or LLC has turned flow control on/off for an LSA link station.

---

**LSA.051****Level:** CE-ERROR**Short Syntax:** LSA.051 FRMR *in\_out* for LSA stn *p\_cep\_id* on SAP *sap\_value*, (nt *network*)**Long Syntax:** LSA.051 Frame reject *in\_out* for LSA link station *p\_cep\_id* on SAP *sap\_value*, (network *network*)**Description:** A frame reject was sent or received for an LSA link station.

---

**LSA.052****Level:** P-TRACE**Short Syntax:** LSA.052 LSA user data from LLC (nt *network*)**Long Syntax:** LSA.052 LSA user data received from LLC (network *network*)**Description:** The LSA net handler has received an 802.2 frame from the LLC application.

---

**LSA.053****Level:** C-INFO**Short Syntax:** LSA.053 LSA rcvd *event* event for SAP/stn *sap\_cep* (nt *network*)**Long Syntax:** LSA.053 LSA received *event* event from LLC for SAP/link station *sap\_cep* (network *network*)**Description:** The LSA net handler received an event notification from the LLC application.

---

**LSA.054****Level:** CI-ERROR**Short Syntax:** LSA.054 LSA frame not sent to host rc *rc* (nt *network*)**Long Syntax:** LSA.054 LSA frame not sent to host - return code *rc* (network *network*)**Description:** The LSA net handler could not send a frame to the host.

---

**LSA.055**

**Level:** C-INFO

**Short Syntax:** LSA.055 APPN Loopback net installed (nt *network*)

**Long Syntax:** LSA.055 APPN Loopback net installed (nt *network*)

**Description:** The APPN net handler for ESCON LLC loopback has been installed.

---

**LSA.056**

**Level:** C-INFO

**Short Syntax:** LSA.056 APPN Loopback net init complete (nt *network*)

**Long Syntax:** LSA.056 APPN Loopback net initialization complete (nt *network*)

**Description:** The APPN net handler for ESCON LLC loopback has been initialized.

---

**LSA.057**

**Level:** C-INFO

**Short Syntax:** LSA.057 LSA net *netnum* disabled by user (nt *network*)

**Long Syntax:** LSA.057 LSA net *netnum* disabled by user (nt *network*)

**Description:** The LSA net handler disable routine has been invoked.

---

**LSA.058**

**Level:** CI-ERROR

**Short Syntax:** LSA.058 LSA can't get IORB for *cause* (nt *network*)

**Long Syntax:** LSA.058 LSA unable to get IORB for *cause* (nt *network*)

**Description:** The LSA net handler could not get an IORB. An event may have occurred which will not be reported to VTAM.

---

**LSA.059**

**Level:** C-INFO

**Short Syntax:** LSA.059 LSA net passed self-test (nt *network*)

**Long Syntax:** LSA.059 LSA net passed self-test (nt *network*)

**Description:** The LSA net handler passed its self-test routine. Both the channel adapter and downstream LAN adapter have gone netup.

---

**LSA.060**

**Level:** C-INFO

**Short Syntax:** LSA.060 LSA net *netnum* netdwn by LAN net *lan\_netnum* netdwn (nt *network*)

**Long Syntax:** LSA.060 LSA net *netnum* went netdown because LAN net *lan\_netnum* went netdown (nt *network*)

**Description:** The LSA net handler went netdown because the downstream LAN adapter went netdown.



---

**LSA.061****Level:** CI-ERROR**Short Syntax:** LSA.061 LSA LLC can't find MAC *macaddr* SAP *sap* for prim *prim* (nt *network*)**Long Syntax:** LSA.061 LSA LLC can't find MAC *macaddr* SAP *sap* for VTAM primitive *prim* (nt *network*)**Description:** LLC could not find the specified SAP open for the MAC address. This error only occurs for LLC loopback.

---

**Level:** Panic**Short Syntax:** Isanomem: LSA handler no memory**Description:** An LSA handler cannot allocate memory for control block(s).**Action:** Contact customer service.

---

**Level:** Panic**Short Syntax:** Isansram: LSA SRAM not found**Description:** The SRAM record for an LSA net handler could not be found.**Action:** Contact customer service.

---

**Level:** Panic**Short Syntax:** Isanolan: LSA target LAN not defined**Description:** LSA target LAN not defined.**Action:** Contact customer service.

---

**Level:** Panic**Short Syntax:** Isanolsa: APPN loopback activated with no LSA net defined**Description:** APPN loopback activated with no LSA net defined.**Action:** Contact customer service.

---

**Level:** Panic**Short Syntax:** Isabcall: bad call to routine**Description:** An invalid call was made to a routine.**Action:** Contact customer service.

---

## MPC+ Virtual Network Interface (MPC) Messages

This section describes MPC+ Channel Network Interface (MPC+) messages. For information on message content and how to use the message, refer to the “Introduction” in *ELS Messages*.

---

### MPC.001

**Level:** UE-ERROR

**Short Syntax:** MPC.001 *file( line)*: No IORB allocated (nt *network*)

**Long Syntax:** MPC.001 *file( line)*: No IORB could be allocated (network *network*)

**Description:** MPC+ processing required an IORB that could not be obtained.

---

### MPC.002

**Level:** P-TRACE

**Short Syntax:** MPC.002 *file( line)*: netfout did not send data frame (nt *network*)

**Long Syntax:** MPC.002 *file( line)*: netfout did not send out data frame (network *network*)

**Description:** The MPC+ Net Handler did a netfout that failed to send the frame out.

---

### MPC.003

**Level:** UE-ERROR

**Short Syntax:** MPC.003 *file( line)*: PDU invalid (nt *network*)

**Long Syntax:** MPC.003 *file( line)*: PDU received was invalid (network *network*)

**Description:** The MPC+ PDU was invalid.

**Cause:** The MPC+ Net Handler did not like the PDU that was received over the channel.

**Action:** Contact Software Support.

---

### MPC.004

**Level:** C-TRACE

**Short Syntax:** MPC.004 *file( line)*: input *fsminput* curr stte *curr\_state* new stte *new\_state* actn *action* (nt *network*)

**Long Syntax:** MPC.004 *file( line)*: input *fsminput* current state *curr\_state* new state *new\_state* action *action* (network *network*)

**Description:** Show the inputs to the MPC+ FSM that is given in the message.

---

### MPC.005

**Level:** UE-ERROR

**Short Syntax:** MPC.005 *file( line)*: SDU ( *rtype\_string*) invalid (nt *network*)

**Long Syntax:** MPC.005 *file( line)*: SDU ( *rtype\_string*) was invalid (network *network*)

**Description:** The MPC+ SDU was invalid.

**Cause:** The MPC+ Net Handler did not like the SDU in the PDU that was received over the channel.

**Action:** Contact Software Support.

---

**MPC.006****Level:** UE-ERROR**Short Syntax:** MPC.006 *file( line): no cbtype\_string* CB available (nt *network*)**Long Syntax:** MPC.006 *file( line): no cbtype\_string* control block available (network *network*)**Description:** Storage for a control block or its resources (i.e. IORBs) was not able to be obtained for MPC+ Net Handler.

---

**MPC.007****Level:** UE-ERROR**Short Syntax:** MPC.007 *file( line): conntype\_string\_* equal user data (nt *network*)**Long Syntax:** MPC.007 *file( line): conntype\_string\_* Virtual Circuit user data was equal (network *network*)**Description:** The user\_data on the virtual circuit was the same.**Cause:** Both VTAM and the MPC+ Net Handler picked the same user data.**Action:** If the connection type is CM, then try to bring up the MPC+ Group again. Hopefully, the random number in the user data will be different the next time.**Action:** If the User connection, then try to modify the user data. Note-APPN connections use the control point names.

---

**MPC.008****Level:** UE-ERROR**Short Syntax:** MPC.008 *file( line): cbtype\_string* CB was not found for *cmdtype\_string* (nt *network*)**Long Syntax:** MPC.008 *file( line): cbtype\_string* control block could not be located for *cmdtype\_string* (network *network*)**Description:** The MPC+ control block for the command (primitive/SDU) could not be located.**Cause:** The control block was already freed because the resources have come down.**Action:** Typically, No action is required.

---

**MPC.009****Level:** U-INFO**Short Syntax:** MPC.009 *file( line): fsmtype\_string* FSM invalid, input = *input* state = *state* (nt *network*)**Long Syntax:** MPC.009 *file( line): fsmtype\_string* FSM had invalid input, input = *input* state = *state* (network *network*)**Description:** One the the MPC+ FSMs received an input that should not occur in the current state.**Action:** Typically, No action is required. If the problem persists, contact Software Support.

---

**MPC.010**

**Level:** UE-ERROR

**Short Syntax:** MPC.010 *file( line): Primitive ( primtype\_string) invalid (nt network)*

**Long Syntax:** MPC.010 *file( line): Primitive ( primtype\_string) was invalid (network network)*

**Description:** The MPC+ primitive was invalid.

**Cause:** The MPC+ Net Handler did not like the primitive it received from other processing in the box.

**Action:** Contact Software Support.

---

**MPC.011**

**Level:** C-INFO

**Short Syntax:** MPC.011 *file( line): Primitive ( primtype\_string) was a dup (nt network)*

**Long Syntax:** MPC.011 *file( line): Primitive ( primtype\_string) was a duplicate (network network)*

**Description:** The MPC+ primitive was for a resource that was already active or in the process of becoming active.

**Action:** Typically, No action is required. If the problem persists, contact Software Support.

---

**MPC.012**

**Level:** P-TRACE

**Short Syntax:** MPC.012 *file( line): conntype\_string conn congested (nt network)*

**Long Syntax:** MPC.012 *file( line): conntype\_string connection is congested (network network)*

**Description:** The connection that the MPC+ PDU was received over was congested so the PDU was discarded.

**Action:** Typically, No action is required. If the problem persists, contact Software Support.

---

**MPC.013**

**Level:** UI-ERROR

**Short Syntax:** MPC.013 *file( line): cmd ( commtype\_string) was un supp (nt network)*

**Long Syntax:** MPC.013 *file( line): command ( commtype\_string) was unsupported (network network)*

**Description:** The command from the Device Driver was unsupported.

**Action:** Contact Software Support.

---

**MPC.014**

**Level:** UI-ERROR

**Short Syntax:** MPC.014 *file( line): no support for routine\_string (nt network)*

**Long Syntax:** MPC.014 *file( line): no support for routine\_string (network network)*

**Description:** A routine for the MPC+ Net Handler was invoked that is not supported.

**Action:** Contact Software Support.

---

**MPC.015****Level:** C-INFO**Short Syntax:** MPC.015 *file( line)*: subchnnl ( *local\_sc\_num*) not expectng *cmd\_string* cmd (nt *network*)**Long Syntax:** MPC.015 *file( line)*: local subchannel ( *local\_sc\_num*) not expecting *cmd\_string* command in current state (*network network*)**Description:** An MPC+ subchannel received a command that was not expected in its current state. The command was ignored**Cause:** VTAM resent the command that was already processed for the subchannel.**Action:** Typically, No action is required. If the problem persists, contact Software Support.

---

**MPC.016****Level:** UI-ERROR**Short Syntax:** MPC.016 *file( line)*: timer ( *timer\_string*) popped when not running (nt *network*)**Long Syntax:** MPC.016 *file( line)*: timer ( *timer\_string*) popped when it was not currently running (*network network*)**Description:** An MPC+ timer was running when the processing did not think it was running.**Action:** Contact Software Support.

---

**MPC.017****Level:** UE-ERROR**Short Syntax:** MPC.017 *file( line)*: XID2( *xid2\_type*) failed validation (nt *network*)**Long Syntax:** MPC.017 *file( line)*: XID2( *xid2\_type*) failed was validation (*network network*)**Description:** The MPC+ XID2 received failed its validation checks and will be consider bad.**Cause:** The random numbers in the XID2 exchange were the same in the MPC+ Net Handler and VTAM.**Action:** Try to bring up the MPC Group again. Hopefully, different random number will be exchanged the next time.

---

**MPC.018****Level:** C-INFO**Short Syntax:** MPC.018 *file( line)*: dup. PDU was received (nt *network*)**Long Syntax:** MPC.018 *file( line)*: A duplicate PDU was received (*network network*)**Description:** The MPC+ Sequence Manager discarded a duplicate PDU that was received.**Action:** No action is required.

---

**MPC.019****Level:** UI-ERROR**Short Syntax:** MPC.019 *file( line)*: *conn\_string* connection cleaned up by Seq. Manager (nt *network*)**Long Syntax:** MPC.019 *file( line)*: *conn\_string* connection was cleaned up by Sequence Manager (*network network*)**Description:** The MPC+ Sequence Manager cleaned up the connection because of sequencing or acknowledgement problems.

**Cause:** Data got out of sequence and was not able to recover.

**Action:** The connections should come back and recover. If the problem continues to happen, then check that the sequence timer value for the connection is not too low. Increase the sequence timer value for the connection if it may be too low. The problem could have been due to delays in traffic that the sequence timer value was not high enough.

**Cause:** Data was not being acknowledged from VTAM in a timely matter.

**Action:** If data was still flowing, then may need to modify the sequence timer value for the connection.

### MPC.020

**Level:** P-TRACE

**Short Syntax:** MPC.020 *file( line)*: MPC+ *command\_string* to base channel (nt *network*)

**Long Syntax:** MPC.020 *file( line)*: MPC+ *command\_string* sent to base channel (network *network*)

**Description:** The MPC+ Net Handler sent an MPC command or data to the base channel Net Handler.

### MPC.021

**Level:** P-TRACE

**Short Syntax:** MPC.021 *file( line)*: MPC+ *command\_string* from base channel (nt *network*)

**Long Syntax:** MPC.021 *file( line)*: MPC+ *command\_string* received from base channel (network *network*)

**Description:** The MPC+ Net Handler received an MPC command or data from the base channel Net Handler.

### MPC.022

**Level:** UE-ERROR

**Short Syntax:** MPC.022 *file( line)*: *ru\_string* invalid. *err\_string*: *err\_data* (nt *network*)

**Long Syntax:** MPC.022 *file( line)*: *ru\_string* validation failed. *err\_string*: *err\_data* (network *network*)

**Description:** Configuration type parameters failed validation.

**Cause:** Invalid data configured at this end or received from the other end

**Action:** Fix configuration.

### MPC.023

**Level:** ALWAYS

**Short Syntax:** MPC.023 *file( line)*: Disabled Net( *rea\_string*). *err\_string*: *err\_data* (nt *network*)

**Long Syntax:** MPC.023 *file( line)*: Error: Disabled Network Interface ( *rea\_string*). *err\_string*: *err\_data* (network *network*)

**Description:** Net Handler Interface disabled due to serious error

**Cause:** Storage allocation failure

**Action:** There is not currently enough storage for the configured resources. Storage may become available. To attempt to bring back up the interface, issue test from the operator console.

**Cause:** Attempt by invalid protocol to use interface

**Action:** Probably a software error, check the configuration. If ok, contact customer service.

---

**MPC.024****Level:** C-INFO**Short Syntax:** MPC.024 *file( line)*: MPC+ nt *network* set to IP *IP\_address***Long Syntax:** MPC.024 *file( line)*: MPC+ network *network* set to IP address *IP\_address***Description:** The MPC+ Net Handler has been set to an IP address.

---

**MPC.025****Level:** P-TRACE**Short Syntax:** MPC.025 *file( line)*: MPC+ user data to base channel (nt *network*)**Long Syntax:** MPC.025 *file( line)*: MPC+ user data sent to base channel (network *network*)**Description:** The MPC+ Net Handler sent user data to the base channel Net Handler.

---

**MPC.026****Level:** P-TRACE**Short Syntax:** MPC.026 *file( line)*: MPC+ user data from base channel (nt *network*)**Long Syntax:** MPC.026 *file( line)*: MPC+ user data received from base channel (network *network*)**Description:** The MPC+ Net Handler received user data from the base channel Net Handler.

---

**MPC.027****Level:** UE-ERROR**Short Syntax:** MPC.027 *file( line)*: Wrong protocol tried to use Exclusive Use MPC+ Group (nt *network*)**Long Syntax:** MPC.027 *file( line)*: Wrong protocol tried to use Exclusive Use MPC+ Group (network *network*)**Description:** The MPC+ Group can not be used by the requesting protocol based on the configuration.**Action:** Double check that configuration (Exclusive Use Enable) was correct.

---

**MPC.028****Level:** UE-ERROR**Short Syntax:** MPC.028 *file( line)*: Exclusive Use MPC+ Group already in use by protocol (nt *network*)**Long Syntax:** MPC.028 *file( line)*: Exclusive Use MPC+ Group already in use by protocol (network *network*)**Description:** The MPC+ Group can not be used by the requesting protocol based on the configuration and the fact that another instance of the protocol is using it.**Action:** Double check that configuration (Exclusive Use Enable) was correct.

---

**MPC.029**

**Level:** UE-ERROR

**Short Syntax:** MPC.029 *file( line)*: Subchannel ( *subnum*) READ or WRITE on both sides (nt *network*)

**Long Syntax:** MPC.029 *file( line)*: Subchannel ( *subnum*) is coded READ or coded WRITE on both sides (*network network*)

**Description:** The Subchannel list is either coded as READ on both sides of the channel or coded a WRITE on both sides of the channel.

**Action:** Double check that configuration (READ vs WRITE) was correct.

---

**MPC.030**

**Level:** UE-ERROR

**Short Syntax:** MPC.030 *file( line)*: *cmdtype\_string* was received for SC *subnum* which is not part of this Net (nt *network*)

**Long Syntax:** MPC.030 *file( line)*: *cmdtype\_string* was received for subchannel *subnum* which is not part of this MPC+ NET (*network network*)

**Description:** The Command listed was received for Subchannel that is not part of the Net handler

**Action:** Contact Software Support.

---

**Level:** Panic

**Short Syntax:** mpcnomem: MPC+ Net Handler no memory

**Description:** An MPC+ Net Handler cannot allocate memory for control block(s).

**Action:** Contact customer service.

---

**Level:** Panic

**Short Syntax:** mpcnsram: MPC+ channel SRAM not found

**Description:** The SRAM record for an MPC+ channel Net handler could not be found.

**Action:** Contact customer service.

---

**Level:** Panic

**Short Syntax:** mpcnosub: subch not found

**Description:** The requested logical path and device address was not found in the channel handler subchannel table.

**Action:** Contact customer service.

---

## Logical Link Control (LLC) Messages

This section describes LLC messages. For information on message content and how to use the message, refer to the "Introduction" in *ELS Messages*.



---

**LLC.001****Level:** C-TRACE**Short Syntax:** LLC.001 Sent *frame\_type*, *src\_mac*-> *dst\_mac*, *rif saps src\_sap*-> *dst\_sap*, *nt network***Long Syntax:** LLC.001 Sent *frame\_type*, *src\_mac*-> *dst\_mac*, *rif saps src\_sap*-> *dst\_sap*, *network network***Description:** LLC is sending a frame. Possible frame types are: SABME\_C0 or SABME\_C1 (Set Asynchronous Balanced Mode Extended), DM\_R0 or DM\_R1 (Disconnected Mode), DISC\_C0 or DISC\_C1 (Disconnect), RR\_C0 or RR\_C1 or RR\_R0 or RR\_R1 (Receiver Ready), RNR\_C0 or RNR\_C1 or RNR\_R0 or RNR\_R1 (Receiver Not Ready), REJ\_C0 or REJ\_C1 or REJ\_R0 or REJ\_R1 (Reject), UA\_R0 or UA\_R1 (Unnumbered Acknowledgement), FRMR\_R0 or FRMR\_R1 (Frame Reject), and I\_C0 or I\_C1 or I\_R0 or I\_R1 (Information Frame). The abbreviation suffixes are C0 (command, poll bit off), C1 (command, poll bit on), R0 (response, final bit off), and R1 (response, final bit on).

---

**LLC.002****Level:** C-TRACE**Short Syntax:** LLC.002 *ev= llc\_event* in *st= llc\_state*, *llc2\_connection*, *nt network***Long Syntax:** LLC.002 *event= llc\_event* in *state= llc\_state*, *llc2\_connection*, *network network***Description:** An event occurred on an llc2 connection. The LLC2 FSM (Finite State Machine) has been called to process the event. The LLC2 connection is uniquely identified by the combination destination MAC address, source MAC address, destination sap, and source sap on a particular network. The possible events are: SET\_ABME (user request to connect to remote), SET\_ADM (user request to disconnect from remote), SEND\_BTU (user request to send data), FLOW\_REQ\_ON (user request to turn off local busy condition), FLOW\_REQ\_OFF (user request to turn on local busy condition), T1\_EXP (T1 timer expiration), T2\_EXP (T2 timer expiration), Ti\_EXP (Ti timer expiration), OS\_I\_C0 or OS\_I\_C1 or OS\_I\_R0 or OS\_I\_R1 (Ns on I-frame is out of sequence), I\_C0 or I\_C1 or I\_R0 or I\_R1 (valid I-frame received), RR\_C0 or RR\_C1 or RR\_R0 or RR\_R1 (RR frame received), RNR\_C0 or RNR\_C1 or RNR\_R0 or RNR\_R1 (RNR frame received), REJ\_C0 or REJ\_C1 or REJ\_R0 or REJ\_R1 (REJ frame received), UA\_R0 or UA\_R1 (UA frame received), DISC\_C0 or DISC\_C1 (DISC frame received), DM\_R0 or DM\_R1 (DM frame received), FRMR\_R0 or FRMR\_R1 (FRMR frame received), BAD\_FRAME\_0 or BAD\_FRAME\_1 (received frame will generate FRMR), SABME\_C0 or SABME\_C1 (SABME frame received), and SEND\_I\_POLL (Sending I frame with Poll bit on). The abbreviation suffixes are C0 (command, poll bit off), C1 (command, poll bit on), R0 (response, final bit off), and R1 (response, final bit on).

---

**LLC.003****Level:** C-INFO**Short Syntax:** LLC.003 *llc\_state*-> *llc\_state*, *llc2\_connection*, *nt network***Long Syntax:** LLC.003 *llc\_state* to *llc\_state*, *llc2\_connection*, *network network***Description:** There is LLC2 state change. The possible states are: DISCONNECTED (initial state), LINK\_OPENING (link establishment in progress), DISCONNECTING (DISC sent, awaiting DM), FRMR\_SENT (frmr sent), LINK\_OPENED (normal state), LOCAL\_BUSY (local is busy), REJECTION (remote sent an out of sequence frame), CHECKPOINTING (poll sent, awaiting response sending of data suspended), CKPT\_LB (combination state), CKPT\_REJ (combination state), RESETTING (awaiting user response to reset), REMOTE\_BUSY (remote is busy), LB\_RB (combination state), REJ\_LB (combination state), REJ\_RB (combination state), CKPT\_REJ\_LB (combination state), CKPT\_CLR (clearing from CKPT\_LB state), CKPT\_REJ\_CLR (clearing from CKPT\_REJ\_LB state), REJ\_LB\_RB (combination state), FRMR\_RECEIVED (received frmr). The abbreviations above are

CKPT=CHECKPOINTING, CLR=CLEARING, LB=LOCAL BUSY, RB=REMOTE BUSY, and REJ=REJECTION.

---

**LLC.004**

**Level:** C-INFO

**Short Syntax:** LLC.004 Up evt *user\_event* args *user\_value/ event\_reason* on *llc2-conn*

**Long Syntax:** LLC.004 Upcall user event *user\_event user\_value event\_reason* on *llc2-conn*

**Description:** LLC2 event upcall is occurring. Some of the arguments on the upcall are shown. User Cookie is meaningful to the router software running over the LLC subsystem. Event reason sometimes further specifies the event. The possible upcall events are: CONN\_IND (cookie=session, reason=none), CONN\_IND\_PASS (cookie=sap, reason=none), CONN\_CONFIRM (cookie=session, reason=none), DISC\_IND (cookie=session, possible reasons: local term (disconnecting), remote term, conn refused, local term (disconnected)), RESET\_IND (cookie=session, possible reasons: local reset, remote reset, frmr rcvd, frmr sent), RESET\_CONF (cookie=session, reason=none), FLOW\_IND (cookie=session, possible reasons: flow off, flow on), and DISC\_CONFIRM (cookie=session, reason=none).

---

**LLC.005**

**Level:** C-INFO

**Short Syntax:** LLC.005 prim *user\_primitive* sap *SAP\_value* on nt *network*

**Long Syntax:** LLC.005 user primitive *user\_primitive* sap *SAP\_value* on network *network*

**Description:** A sap-related LLC user-primitive was called. The possible SAP primitives are: OPEN\_SAP, CLOSE\_SAP, CLOSE\_SAP\_FORCED, MODIFY\_SAP, OPEN\_STATION, and UNITDATA.

---

**LLC.006**

**Level:** C-INFO

**Short Syntax:** LLC.006 prim *user\_primitive, llc2\_connection, nt network*

**Long Syntax:** LLC.006 primitive *user\_primitive, llc2\_connection, network network*

**Description:** A llc2 connection non-data user-primitive was called. The possible primitives are: CLOSE\_STATION, CLOSE\_STATION\_FORCED, CONNECT\_REQUEST, CONNECT\_RESPONSE, DISCONNECT\_REQUEST, RESET\_REQUEST, RESET\_RESPONSE, FLOW\_REQ.

---

**LLC.007**

**Level:** C-TRACE

**Short Syntax:** LLC.007 data prim, *llc2\_connection, nt network*

**Long Syntax:** LLC.007 data primitive, *llc2\_connection, network network*

**Description:** A DATA\_REQUEST data primitive was called. DATA\_REQUEST passes the data in buffer memory.

---

**LLC.008**

**Level:** C-TRACE

**Short Syntax:** LLC.008 data prim, *llc2\_connection, nt network*

**Long Syntax:** LLC.008 data primitive, *llc2\_connection, network network*

**Description:** A DATA\_LOCAL data primitive was called. DATA\_LOCAL passes the data in data memory.

---

**LLC.009****Level:** C-TRACE**Short Syntax:** LLC.009 unitdata prim, sap *SAP\_value*, nt *network***Long Syntax:** LLC.009 unitdata primitive, sap *SAP\_value* network *network***Description:** A UNITDATA llc1 data primitive was called.

---

**LLC.010****Level:** UI-ERROR**Short Syntax:** LLC.010 out q too big, *llc2\_connection*, nt *network***Long Syntax:** LLC.010 outboudn queue too big, *llc2\_connection*, network *network***Description:** The outbound queue has grown grossly large. The llc2 connection is being automatically terminated.**Cause:** LLC application is not responding to flow control.**Action:** Contact customer service.

---

**LLC.011****Level:** UI-ERROR**Short Syntax:** LLC.011 No buf to dup I-frame, *llc2\_connection*, nt *network***Long Syntax:** LLC.011 No buffer available to duplicate I-frame, *llc2\_connection*, network *network***Description:** No buffer available to duplicate I-frame.**Cause:** Severe packet buffer shortage.**Action:** Check memory statistics in GWCON to verify packet buffer level. Reduce buffer usage of other router software. Reduce buffer usage by reducing LLC connections, by changing LLC configuration, especially making sure that LLC Transmit and Receive windows are normal sizes.

---

**LLC.012****Level:** UI-ERROR**Short Syntax:** LLC.012 No mem to dup I-frame, *llc2\_connection*, nt *network***Long Syntax:** LLC.012 No memory available to duplicate I-frame, *llc2\_connection*, network *network***Description:** No memory to duplicate I-frame.**Cause:** Memory shortage.**Action:** Reduce memory usage by reducing tables in other software. Reduce memory by reducing LLC connections, by changing LLC configuration, especially making sure that LLC Transmit and Receive windows are normal sizes.

---

**LLC.013****Level:** UI-ERROR**Short Syntax:** LLC.013 No buf for LLC frame, *llc2\_connection*, nt *network***Long Syntax:** LLC.013 No buffer for LLC frame, *llc2\_connection*, network *network***Description:** A buffer could not be obtained to to build an LLC Supervisory or Unnumbered frame. No loss of data integrity has occurred yet, but unless buffers for this purpose become available within a few seconds, the other end of the LLC2 connection will most likely terminate this LLC connection as part of the normal LLC2 protocol.

**Cause:** Severe packet buffer shortage.

**Action:** Check memory statistics in GWCON to verify packet buffer level.

---

#### LLC.014

**Level:** UI-ERROR

**Short Syntax:** LLC.014 fr type inv, *llc2\_connection*, nt *network*

**Long Syntax:** LLC.014 frame type invalid, *llc2\_connection*, network *network*

**Description:** The frame type the LLC is trying to build is invalid.

**Cause:** Hardware failure or software bug.

**Action:** Contact customer service.

---

#### LLC.015

**Level:** UI-ERROR

**Short Syntax:** LLC.015 Inv LLC2 ev *event\_code\_number*

**Long Syntax:** LLC.015 Invalid LLC2 FSM event *event\_code\_number*

**Description:** The LLC2 Finite State Machine (FSM) was called with an event that was out of range.

**Cause:** Hardware failure or software bug.

**Action:** Contact customer service.

---

#### LLC.016

**Level:** UI-ERROR

**Short Syntax:** LLC.016 inv nt typ *network\_type* on nt *network*

**Long Syntax:** LLC.016 invalid network type *network\_type* on network *network*

**Description:** An OPEN SAP operation was tried on a network type that LLC does not support. Network types Token-Ring, Ethernet, and FDDI are supported.

**Cause:** Software bug.

**Action:** Contact customer service.

---

#### LLC.017

**Level:** UI-ERROR

**Short Syntax:** LLC.017 dup sap *SAP\_value* on nt *network*

**Long Syntax:** LLC.017 duplicate sap *SAP\_value* on network *network*

**Description:** A OPEN SAP operation was tried on a sap that has already been opened.

**Cause:** Software bug.

**Action:** Contact customer service.

---

#### LLC.018

**Level:** UI-ERROR

**Short Syntax:** LLC.018 No mem for sap blk on nt *network*

**Long Syntax:** LLC.018 No memory for SAP control block on network *network*

**Description:** Unable to allocate memory for SAP control block.

**Cause:** Severe shortage of memory.

**Action:** Reduce table sizes in other protocols, use system with less protocols, expand memory in router.

#### LLC.019

**Level:** UI-ERROR

**Short Syntax:** LLC.019 No mem for stn blk on nt *network*

**Long Syntax:** LLC.019 No memory for station control block on network *network*

**Description:** Unable to allocate memory for station control block.

**Cause:** Severe shortage of memory.

**Action:** Reduce table sizes in other protocols, use system with less protocols, expand memory in router. Reduce number of LLC2 connections.

#### LLC.020

**Level:** U-INFO

**Short Syntax:** LLC.020 UI frm drp *llc2\_connection*, nt *network*

**Long Syntax:** LLC.020 UI frame dropped, *llc2\_connection*, network *network*

**Description:** UI frame refused by the local application within the router.

**Cause:** The frame was not the type the local application wanted to handle.

**Action:** None.

#### LLC.021

**Level:** U-INFO

**Short Syntax:** LLC.021 TST frm refused *llc2\_connection*, nt *network*

**Long Syntax:** LLC.021 TEST frame refused, *llc2\_connection*, network *network*

**Description:** TEST frame refused by the local application within the router. The frame is passed on to the bridge code, etc.

**Cause:** The frame was not the type the local application wanted to handle.

**Action:** None.

#### LLC.022

**Level:** U-INFO

**Short Syntax:** LLC.022 XID frm refused *llc2\_connection*, nt *network*

**Long Syntax:** LLC.022 XID frame refused, *llc2\_connection*, network *network*

**Description:** XID frame refused by the local application within the router. The frame is passed on to the bridge code, etc.

**Cause:** The frame was not the type the local application wanted to handle.

**Action:** None.

#### LLC.023

**Level:** C-INFO

**Short Syntax:** LLC.023 Upcall frm *frame\_type*, *src\_mac-> dst\_mac*, rif saps *src\_sap-> dst\_sap*, nt *network*

**Long Syntax:** LLC.023 Upcall frame *frame\_type*, *src\_mac-> dst\_mac*, rif saps *src\_sap-> dst\_sap*, network *network*

**Description:** LLC makes an upcall providing the LLC with a unitdata frame. The possible

unidata frames are: TEST\_C0 or TEST\_C1 or TEST\_R0 or TEST\_R1 (TEST frame), XID\_C0 or XID\_C1 or XID\_R0 or XID\_R1 (Exchange Identification frame), UI\_C0 or UI\_R0 (Unnumbered Information). The abbreviation suffixes are C0 (command, poll bit off), C1 (command, poll bit on), R0 (response, final bit off), and R1 (response, final bit on).

#### LLC.024

**Level:** UI-ERROR

**Short Syntax:** LLC.024 llc2 out drp, rsn *reason\_code*, llc2\_connection, nt *network*

**Long Syntax:** LLC.024 llc2 outbound frame dropped, reason *reason\_code*, llc2\_connection, network *network*

**Description:** The sending of an LLC2 related outbound frame failed. The *reason\_code* is the internal error code for the failure.

**Cause:** Miscellaneous handler error. (Reason code 1.)

**Action:** Check for error messages from handler for *network\_name*.

**Cause:** Output queue overflow, or other flow control. (Reason code 2.)

**Action:** Alleviate congestion.

**Cause:** Network down. (Reason code 3.)

**Action:** See why handler thinks network is down.

**Cause:** Dropped by handler to avoid looping, or bad broadcast. (Reason code 4.)

**Action:** Check configuration.

**Cause:** Host down. (Reason code 5.)

**Action:** See why handler thinks host is down.

#### LLC.025

**Level:** UI-ERROR

**Short Syntax:** LLC.025 *frame\_type* out frm drp, rsn *reason\_code*, llc2\_connection, nt *network*

**Long Syntax:** LLC.025 *frame\_type* outbound frame dropped, reason *reason\_code*, llc2\_connection, network *network*

**Description:** The sending of the user's UNITDATA or an LLC-generated XID or TEST response outbound frame failed. The possible frame test are: TEST\_C0 or TEST\_C1 or TEST\_R0 or TEST\_R1 (TEST frame), XID\_C0 or XID\_C1 or XID\_R0 or XID\_R1 (Exchange Identification frame), UI\_C0 or UI\_R0 (Unnumbered Information frame), and unexpected (not one of the above types). The abbreviation suffixes are C0 (command, poll bit off), C1 (command, poll bit on), R0 (response, final bit off), and R1 (response, final bit on).

**Cause:** See LLC.024.

**Action:** See LLC.024

#### LLC.026

**Level:** UI-ERROR

**Short Syntax:** LLC.026 No mem for cfg blk on nt *network*

**Long Syntax:** LLC.026 No memory for LLC CONF BLOCK on network *network*

**Description:** Unable to allocate memory for an LLC\_CONF\_BLOCK at initialization time. LLC configuration defaults are used.

**Cause:** Severe shortage of memory.

**Action:** Reduce table sizes in other protocols, use system with less protocols, expand memory in router.

---

**LLC.027****Level:** U-INFO**Short Syntax:** LLC.027 Read LLC Cfg for nt *network***Long Syntax:** LLC.027 Read LLC Configuration record for network *network***Description:** LLC Configuration record read for this network. This only occurs at initialization time. The values in the LLC configuration record are used as default value on the network.

---

**LLC.028****Level:** U-INFO**Short Syntax:** LLC.028 Inv acc *access\_priority* for nt *network***Long Syntax:** LLC.028 Inv access priority *access\_priority* for network *network***Description:** *access\_priority*, on a network that that is not a token ring must be zero because it is not used.**Cause:** As devices are deleted and added, it is possible for one of the LLC config records to contain a non-zero access priority on a non-Token-Ring LAN interface.**Action:** None. You may reconfigure the LLC config on this network to avoid getting this message.

---

**LLC.029****Level:** UI-ERROR**Short Syntax:** LLC.029 Inv acc *access\_priority* for nt *network***Long Syntax:** LLC.029 Inv acc *access\_priority* for network *network***Description:** The access priority is greater than 7. A default of 0 is used.**Cause:** Configuration memory corruption.**Action:** Reconfigure the LLC on this network to avoid getting this message.

---

**LLC.030****Level:** C-TRACE**Short Syntax:** LLC.030 Inv hw type *hardware\_type* in cfg for nt *network***Long Syntax:** LLC.030 Invalid hardware type *hardware\_type* for network *network***Description:** An LLC config record exists for an interface that does not have a LAN hardware type.**Cause:** As devices are deleted and added, it is possible for one of the LLC config records to contain an interface that is no longer a LAN interface.**Action:** None. Situation is not harmful.

---

**LLC.031****Level:** C-TRACE**Short Syntax:** LLC.031 Inv int *interface\_number* in cfg**Long Syntax:** LLC.031 Invalid interface *interface\_number* in config**Description:** An LLC config record exists for an interface that does not exist.**Cause:** As devices are deleted and added, it is possible for one of the LLC config records to contain an invalid interface number.**Action:** None. Situation is not harmful.

---

**LLC.032**

**Level:** C-INFO

**Short Syntax:** LLC.032 Sent *frame\_type*, *src\_mac*-> *dst\_mac*, *rif saps src\_sap*-> *dst\_sap*, *nt network*

**Long Syntax:** LLC.032 Sent *frame\_type*, *src\_mac*-> *dst\_mac*, *rif saps src\_sap*-> *dst\_sap*, *network network*

**Description:** LLC user is sending a frame, or LLC itself is sending a TEST or XID response frame. The possible frame types are: TEST\_C0 or TEST\_C1 or TEST\_R0 or TEST\_R1 (TEST frame), XID\_C0 or XID\_C1 or XID\_R0 or XID\_R1 (Exchange Identification frame), UI\_C0 or UI\_R0 (Unnumbered Information frame). The abbreviation suffixes are C0 (command, poll bit off), C1 (command, poll bit on), R0 (response, final bit off), and R1 (response, final bit on).

---

**LLC.033**

**Level:** C-INFO

**Short Syntax:** LLC.033 frm to LLC, frm *frame\_type*, *src\_mac*-> *dst\_mac*, *rif saps src\_sap*-> *dst\_sap*, *nt network*

**Long Syntax:** LLC.033 frm to LLC, frm *frame\_type*, *src\_mac*-> *dst\_mac*, *rif saps src\_sap*-> *dst\_sap*, *network network*

**Description:** LLC subsystem itself is responding to a TEST or XID frame. The possible frame types are: TEST\_C0 or TEST\_C1 (TEST frame), and XID\_C0 or XID\_C1 (Exchange Identification frame). The abbreviation suffixes are: C0=(command, poll bit off), and C1=(command, poll bit on),

---

**LLC.034**

**Level:** CI-ERROR

**Short Syntax:** LLC.034 Sent SABME\_C0, *src\_mac*-> *dst\_mac*, *rif saps src\_sap*-> *dst\_sap*, *nt network*

**Long Syntax:** LLC.034 Sent SABME\_C0, *src\_mac*-> *dst\_mac*, *rif saps src\_sap*-> *dst\_sap*, *network network*

**Description:** LLC is sending a Set Asynchronous Balanced Mode Extended frame, as a command, with the poll bit off.

---

**LLC.035**

**Level:** CI-ERROR

**Short Syntax:** LLC.035 Sent SABME\_C1, *src\_mac*-> *dst\_mac*, *rif saps src\_sap*-> *dst\_sap*, *nt network*

**Long Syntax:** LLC.035 Sent SABME\_C1, *src\_mac*-> *dst\_mac*, *rif saps src\_sap*-> *dst\_sap*, *network network*

**Description:** LLC is sending a Set Asynchronous Balanced Mode Extended frame, as a command, with the poll bit on.



---

**LLC.036****Level:** CI-ERROR**Short Syntax:** LLC.036 Sent DM\_R0, *src\_mac-> dst\_mac, rif saps src\_sap-> dst\_sap*, nt network**Long Syntax:** LLC.036 Sent DM\_R0, *src\_mac-> dst\_mac, rif saps src\_sap-> dst\_sap*, network network**Description:** LLC is sending a Disconnected Mode frame, as a response, with the poll bit off.

---

**LLC.037****Level:** CI-ERROR**Short Syntax:** LLC.037 Sent DM\_R1, *src\_mac-> dst\_mac, rif saps src\_sap-> dst\_sap*, nt network**Long Syntax:** LLC.037 Sent DM\_R1, *src\_mac-> dst\_mac, rif saps src\_sap-> dst\_sap*, network network**Description:** LLC is sending a Disconnected Mode frame, as a response, with the poll bit on.

---

**LLC.038****Level:** CI-ERROR**Short Syntax:** LLC.038 Sent DISC\_C0, *src\_mac-> dst\_mac, rif saps src\_sap-> dst\_sap*, nt network**Long Syntax:** LLC.038 Sent DISC\_C0, *src\_mac-> dst\_mac, rif saps src\_sap-> dst\_sap*, network network**Description:** LLC is sending a Disconnect frame, as a command, with the poll bit off.

---

**LLC.039****Level:** CI-ERROR**Short Syntax:** LLC.039 Sent DISC\_C1, *src\_mac-> dst\_mac, rif saps src\_sap-> dst\_sap*, nt network**Long Syntax:** LLC.039 Sent DISC\_C1, *src\_mac-> dst\_mac, rif saps src\_sap-> dst\_sap*, network network**Description:** LLC is sending a Disconnect frame, as a command, with the poll bit on.

---

**LLC.040****Level:** P-TRACE**Short Syntax:** LLC.040 Sent RR\_C0, *src\_mac-> dst\_mac, rif saps src\_sap-> dst\_sap*, nt network**Long Syntax:** LLC.040 Sent RR\_C0, *src\_mac-> dst\_mac, rif saps src\_sap-> dst\_sap*, network network**Description:** LLC is sending a Receiver Ready frame, as a command, with the poll bit off.

---

**LLC.041**

**Level:** P-TRACE

**Short Syntax:** LLC.041 Sent RR\_C1, *src\_mac-> dst\_mac, rif saps src\_sap-> dst\_sap*, nt *network*

**Long Syntax:** LLC.041 Sent RR\_C1, *src\_mac-> dst\_mac, rif saps src\_sap-> dst\_sap*, *network network*

**Description:** LLC is sending a Receiver Ready frame, as a command, with the poll bit on.

---

**LLC.042**

**Level:** P-TRACE

**Short Syntax:** LLC.042 Sent RR\_R0, *src\_mac-> dst\_mac, rif saps src\_sap-> dst\_sap*, nt *network*

**Long Syntax:** LLC.042 Sent RR\_R0, *src\_mac-> dst\_mac, rif saps src\_sap-> dst\_sap*, *network network*

**Description:** LLC is sending a Receiver Ready frame, as a response, with the poll bit off.

---

**LLC.043**

**Level:** P-TRACE

**Short Syntax:** LLC.043 Sent RR\_R1, *src\_mac-> dst\_mac, rif saps src\_sap-> dst\_sap*, nt *network*

**Long Syntax:** LLC.043 Sent RR\_R1, *src\_mac-> dst\_mac, rif saps src\_sap-> dst\_sap*, *network network*

**Description:** LLC is sending a Receiver Ready frame, as a response, with the poll bit on.

---

**LLC.044**

**Level:** P-TRACE

**Short Syntax:** LLC.044 Sent RNR\_C0, *src\_mac-> dst\_mac, rif saps src\_sap-> dst\_sap*, nt *network*

**Long Syntax:** LLC.044 Sent RNR\_C0, *src\_mac-> dst\_mac, rif saps src\_sap-> dst\_sap*, *network network*

**Description:** LLC is sending a Receiver Not Ready frame, as a command, with the poll bit off.

---

**LLC.045**

**Level:** P-TRACE

**Short Syntax:** LLC.045 Sent RNR\_C1, *src\_mac-> dst\_mac, rif saps src\_sap-> dst\_sap*, nt *network*

**Long Syntax:** LLC.045 Sent RNR\_C1, *src\_mac-> dst\_mac, rif saps src\_sap-> dst\_sap*, *network network*

**Description:** LLC is sending a Receiver Not Ready frame, as a command, with the poll bit on.

---

**LLC.046****Level:** P-TRACE**Short Syntax:** LLC.046 Sent RNR\_R0, *src\_mac-> dst\_mac, rif saps src\_sap-> dst\_sap*, nt network**Long Syntax:** LLC.046 Sent RNR\_R0, *src\_mac-> dst\_mac, rif saps src\_sap-> dst\_sap*, network network**Description:** LLC is sending a Receiver Not Ready frame, as a response, with the poll bit off.

---

**LLC.047****Level:** P-TRACE**Short Syntax:** LLC.047 Sent RNR\_R1, *src\_mac-> dst\_mac, rif saps src\_sap-> dst\_sap*, nt network**Long Syntax:** LLC.047 Sent RNR\_R1, *src\_mac-> dst\_mac, rif saps src\_sap-> dst\_sap*, network network**Description:** LLC is sending a Receiver Not Ready frame, as a response, with the poll bit on.

---

**LLC.048****Level:** P-TRACE**Short Syntax:** LLC.048 Sent REJ\_C0, *src\_mac-> dst\_mac, rif saps src\_sap-> dst\_sap*, nt network**Long Syntax:** LLC.048 Sent REJ\_C0, *src\_mac-> dst\_mac, rif saps src\_sap-> dst\_sap*, network network**Description:** LLC is sending a Reject frame, as a command, with the poll bit off.

---

**LLC.049****Level:** P-TRACE**Short Syntax:** LLC.049 Sent REJ\_C1, *src\_mac-> dst\_mac, rif saps src\_sap-> dst\_sap*, nt network**Long Syntax:** LLC.049 Sent REJ\_C1, *src\_mac-> dst\_mac, rif saps src\_sap-> dst\_sap*, network network**Description:** LLC is sending a Reject frame, as a command, with the poll bit on.

---

**LLC.050****Level:** P-TRACE**Short Syntax:** LLC.050 Sent REJ\_R0, *src\_mac-> dst\_mac, rif saps src\_sap-> dst\_sap*, nt network**Long Syntax:** LLC.050 Sent REJ\_R0, *src\_mac-> dst\_mac, rif saps src\_sap-> dst\_sap*, network network**Description:** LLC is sending a Reject frame, as a response, with the poll bit off.

---

**LLC.051**

**Level:** P-TRACE

**Short Syntax:** LLC.051 Sent REJ\_R1, *src\_mac-> dst\_mac, rif saps src\_sap-> dst\_sap, nt network*

**Long Syntax:** LLC.051 Sent REJ\_R1, *src\_mac-> dst\_mac, rif saps src\_sap-> dst\_sap, network network*

**Description:** LLC is sending a Reject frame, as a response, with the poll bit on.

---

**LLC.052**

**Level:** CI-ERROR

**Short Syntax:** LLC.052 Sent UA\_R0, *src\_mac-> dst\_mac, rif saps src\_sap-> dst\_sap, nt network*

**Long Syntax:** LLC.052 Sent UA\_R0, *src\_mac-> dst\_mac, rif saps src\_sap-> dst\_sap, network network*

**Description:** LLC is sending an Unnumbered Acknowledgement frame, as a response, with the poll bit off.

---

**LLC.053**

**Level:** CI-ERROR

**Short Syntax:** LLC.053 Sent UA\_R1, *src\_mac-> dst\_mac, rif saps src\_sap-> dst\_sap, nt network*

**Long Syntax:** LLC.053 Sent UA\_R1, *src\_mac-> dst\_mac, rif saps src\_sap-> dst\_sap, network network*

**Description:** LLC is sending an Unnumbered Acknowledgement frame, as a response, with the poll bit on.

---

**LLC.054**

**Level:** CI-ERROR

**Short Syntax:** LLC.054 Sent FRMR\_R0, *src\_mac-> dst\_mac, rif saps src\_sap-> dst\_sap, nt network*

**Long Syntax:** LLC.054 Sent FRMR\_R0, *src\_mac-> dst\_mac, rif saps src\_sap-> dst\_sap, network network*

**Description:** LLC is sending a Frame Reject frame, as a response, with the poll bit off.

---

**LLC.055**

**Level:** CI-ERROR

**Short Syntax:** LLC.055 Sent FRMR\_R1, *src\_mac-> dst\_mac, rif saps src\_sap-> dst\_sap, nt network*

**Long Syntax:** LLC.055 Sent FRMR\_R1, *src\_mac-> dst\_mac, rif saps src\_sap-> dst\_sap, network network*

**Description:** LLC is sending a Frame Reject frame, as a response, with the poll bit on.

---

**LLC.056****Level:** C-INFO**Short Syntax:** LLC.056 Sent I\_C0, *src\_mac-> dst\_mac, rif saps src\_sap-> dst\_sap*, nt  
*network***Long Syntax:** LLC.056 Sent I\_C0, *src\_mac-> dst\_mac, rif saps src\_sap-> dst\_sap*, network  
*network***Description:** LLC is sending an Information frame, as a command, with the poll bit off.

---

**LLC.057****Level:** C-INFO**Short Syntax:** LLC.057 Sent I\_C1, *src\_mac-> dst\_mac, rif saps src\_sap-> dst\_sap*, nt  
*network***Long Syntax:** LLC.057 Sent I\_C1, *src\_mac-> dst\_mac, rif saps src\_sap-> dst\_sap*, network  
*network***Description:** LLC is sending an Information frame, as a command, with the poll bit on.

---

**LLC.058****Level:** C-INFO**Short Syntax:** LLC.058 Sent I\_R0, *src\_mac-> dst\_mac, rif saps src\_sap-> dst\_sap*, nt  
*network***Long Syntax:** LLC.058 Sent I\_R0, *src\_mac-> dst\_mac, rif saps src\_sap-> dst\_sap*, network  
*network***Description:** LLC is sending an Information frame, as a response, with the poll bit off.

---

**LLC.059****Level:** C-INFO**Short Syntax:** LLC.059 Sent I\_R1, *src\_mac-> dst\_mac, rif saps src\_sap-> dst\_sap*, nt  
*network***Long Syntax:** LLC.059 Sent I\_R1, *src\_mac-> dst\_mac, rif saps src\_sap-> dst\_sap*, network  
*network***Description:** LLC is sending an Information frame, as a response, with the poll bit on.

---

**LLC.060****Level:** C-INFO**Short Syntax:** LLC.060 Sent Unknown, *src\_mac-> dst\_mac, rif saps src\_sap-> dst\_sap*, nt  
*network***Long Syntax:** LLC.060 Sent Unknown, *src\_mac-> dst\_mac, rif saps src\_sap-> dst\_sap*,  
network *network***Description:** LLC is sending an unexpected unknown frame. Report this to customer  
service; this should never happen.

---

**LLC.061**

**Level:** CI-ERROR

**Short Syntax:** LLC.061 ev=SET\_ABME in st= *llc\_state, llc2\_connection*, nt *network*

**Long Syntax:** LLC.061 event=SET\_ABME in state= *llc\_state, llc2\_connection*, network *network*

**Description:** This is a SET\_ABME FSM event. An LLC2 user requested to connect to an LLC2 connection. The router called the LLC2 FSM (Finite State Machine) to process the event. The combination destination MAC address, source MAC address, destination SAP, and source SAP on a particular network uniquely identified the LLC2 connection.

---

**LLC.062**

**Level:** CI-ERROR

**Short Syntax:** LLC.062 ev=SET\_ADM in st= *llc\_state, llc2\_connection*, nt *network*

**Long Syntax:** LLC.062 event=SET\_ADM in state= *llc\_state, llc2\_connection*, network *network*

**Description:** This is a SET\_ADM FSM event. An LLC2 user requested to disconnect an LLC2 connection.

---

**LLC.063**

**Level:** C-INFO

**Short Syntax:** LLC.063 ev=SEND\_BTU in st= *llc\_state, llc2\_connection*, nt *network*

**Long Syntax:** LLC.063 event=SEND\_BTU in state= *llc\_state, llc2\_connection*, network *network*

**Description:** This is a SEND\_BTU FSM event. An LLC2 user requested to send data on an LLC2 connection.

---

**LLC.064**

**Level:** C-INFO

**Short Syntax:** LLC.064 ev=T1\_EXP in st= *llc\_state, llc2\_connection*, nt *network*

**Long Syntax:** LLC.064 event=T1\_EXP in state= *llc\_state, llc2\_connection*, network *network*

**Description:** A T1 timer expiration FSM event occurred on an LLC2 connection.

---

**LLC.065**

**Level:** C-INFO

**Short Syntax:** LLC.065 ev=T2\_EXP in st= *llc\_state, llc2\_connection*, nt *network*

**Long Syntax:** LLC.065 event=T2\_EXP in state= *llc\_state, llc2\_connection*, network *network*

**Description:** A T2 timer expiration FSM event occurred on an LLC2 connection.

---

**LLC.066**

**Level:** C-INFO

**Short Syntax:** LLC.066 ev=Ti\_EXP in st= *llc\_state, llc2\_connection*, nt *network*

**Long Syntax:** LLC.066 event=Ti\_EXP in state= *llc\_state, llc2\_connection*, network *network*

**Description:** An inactivity timer expiration FSM event occurred on an LLC2 connection.

**Cause:** No data traffic occurred on the connection for the inactivity timer period, which is normally 30 seconds.

**Action:** None.

---

**LLC.067****Level:** C-INFO**Short Syntax:** LLC.067 ev=SEND\_I\_POLL in st= *llc\_state, llc2\_connection, nt network***Long Syntax:** LLC.067 event=SEND\_I\_POLL in state= *llc\_state, llc2\_connection, network network***Description:** This is an FSM event that occurred on an LLC2 connection. LLC2 is sending an Information frame, with the poll bit on.

---

**LLC.068****Level:** CI-ERROR**Short Syntax:** LLC.068 ev=OS\_I\_C0 in st= *llc\_state, llc2\_connection, nt network***Long Syntax:** LLC.068 event=OS\_I\_C0 in state= *llc\_state, llc2\_connection, network network***Description:** An OS\_I\_C0 frame received FSM event occurred on an LLC2 connection. The network received an out-of-sequence frame. The I-frame was a command with the poll bit off.**Cause:** The router missed an I-frame.**Action:** None.

---

**LLC.069****Level:** CI-ERROR**Short Syntax:** LLC.069 ev=OS\_I\_C1 in st= *llc\_state, llc2\_connection, nt network***Long Syntax:** LLC.069 event=OS\_I\_C1 in state= *llc\_state, llc2\_connection, network network***Description:** An OS\_I\_C0 frame received FSM event occurred on an LLC2 connection. The network received an out-of-sequence frame. The I-frame was a command with the poll bit on.**Cause:** The router missed an I-frame.**Action:** None.

---

**LLC.070****Level:** CI-ERROR**Short Syntax:** LLC.070 ev=OS\_I\_R0 in st= *llc\_state, llc2\_connection, nt network***Long Syntax:** LLC.070 event=OS\_I\_R0 in state= *llc\_state, llc2\_connection, network network***Description:** An OS\_I\_R0 frame received FSM event occurred on an LLC2 connection. The network received an out-of-sequence frame. The I-frame was a response with the poll bit off.**Cause:** The router missed an I-frame.**Action:** None.

---

**LLC.071**

**Level:** CI-ERROR

**Short Syntax:** LLC.071 ev=OS\_I\_R1 in st= *llc\_state, llc2\_connection*, nt *network*

**Long Syntax:** LLC.071 event=OS\_I\_R1 in state= *llc\_state, llc2\_connection*, network *network*

**Description:** An OS\_I\_R1 frame received FSM event occurred on an LLC2 connection. The network received an out-of-sequence frame. The I-frame was a response with the poll bit off.

**Cause:** The router missed an I-frame.

**Action:** None.

---

**LLC.072**

**Level:** C-INFO

**Short Syntax:** LLC.072 ev=I\_C0 in st= *llc\_state, llc2\_connection*, nt *network*

**Long Syntax:** LLC.072 event=I\_C0 in state= *llc\_state, llc2\_connection*, network *network*

**Description:** A valid information frame received FSM event occurred on an LLC2 connection. The information frame was a command with the poll bit off.

---

**LLC.073**

**Level:** C-INFO

**Short Syntax:** LLC.073 ev=I\_C1 in st= *llc\_state, llc2\_connection*, nt *network*

**Long Syntax:** LLC.073 event=I\_C1 in state= *llc\_state, llc2\_connection*, network *network*

**Description:** A valid information frame received FSM event occurred on an LLC2 connection. The information frame was a command with the poll bit on.

---

**LLC.074**

**Level:** C-INFO

**Short Syntax:** LLC.074 ev=I\_R0 in st= *llc\_state, llc2\_connection*, nt *network*

**Long Syntax:** LLC.074 event=I\_R0 in state= *llc\_state, llc2\_connection*, network *network*

**Description:** A valid information frame received FSM event occurred on an LLC2 connection. The information frame was a response with the poll bit off.

---

**LLC.075**

**Level:** C-INFO

**Short Syntax:** LLC.075 ev=I\_R1 in st= *llc\_state, llc2\_connection*, nt *network*

**Long Syntax:** LLC.075 event=I\_R1 in state= *llc\_state, llc2\_connection*, network *network*

**Description:** A valid information frame received FSM event occurred on an LLC2 connection. The information frame was a response with the poll bit on.

---

**LLC.076**

**Level:** P-TRACE

**Short Syntax:** LLC.076 ev=RR\_C0 in st= *llc\_state, llc2\_connection*, nt *network*

**Long Syntax:** LLC.076 event=RR\_C0 in state= *llc\_state, llc2\_connection*, network *network*

**Description:** A Receive Ready frame received FSM event occurred on an LLC2 connection. The frame was a command with the poll bit off.



---

**LLC.077****Level:** P-TRACE**Short Syntax:** LLC.077 ev=RR\_C1 in st= *llc\_state, llc2\_connection, nt network***Long Syntax:** LLC.077 event=RR\_C1 in state= *llc\_state, llc2\_connection, network network***Description:** A Receive Ready frame received FSM event occurred on an LLC2 connection. The frame was a command with the poll bit on.

---

**LLC.078****Level:** P-TRACE**Short Syntax:** LLC.078 ev=RR\_R0 in st= *llc\_state, llc2\_connection, nt network***Long Syntax:** LLC.078 event=RR\_R0 in state= *llc\_state, llc2\_connection, network network***Description:** A Receive Ready frame received FSM event occurred on an LLC2 connection. The frame was a response with the poll bit off.

---

**LLC.079****Level:** P-TRACE**Short Syntax:** LLC.079 ev=RR\_R1 in st= *llc\_state, llc2\_connection, nt network***Long Syntax:** LLC.079 event=RR\_R1 in state= *llc\_state, llc2\_connection, network network***Description:** A Receive Ready frame received FSM event occurred on an LLC2 connection. The frame was a response with the poll bit on.

---

**LLC.080****Level:** P-TRACE**Short Syntax:** LLC.080 ev=RNR\_C0 in st= *llc\_state, llc2\_connection, nt network***Long Syntax:** LLC.080 event=RNR\_C0 in state= *llc\_state, llc2\_connection, network network***Description:** A Receive Not Ready frame received FSM event occurred on an LLC2 connection. The frame was a command with the poll bit off.

---

**LLC.081****Level:** P-TRACE**Short Syntax:** LLC.081 ev=RNR\_C1 in st= *llc\_state, llc2\_connection, nt network***Long Syntax:** LLC.081 event=RNR\_C1 in state= *llc\_state, llc2\_connection, network network***Description:** A Receive Not Ready frame received FSM event occurred on an LLC2 connection. The frame was a command with the poll bit on.

---

**LLC.082****Level:** P-TRACE**Short Syntax:** LLC.082 ev=RNR\_R0 in st= *llc\_state, llc2\_connection, nt network***Long Syntax:** LLC.082 event=RNR\_R0 in state= *llc\_state, llc2\_connection, network network***Description:** A Receive Not Ready frame received FSM event occurred on an LLC2 connection. The frame was a response with the poll bit off.

---

**LLC.083**

**Level:** P-TRACE

**Short Syntax:** LLC.083 ev=RNR\_R1 in st= *llc\_state, llc2\_connection, nt network*

**Long Syntax:** LLC.083 event=RNR\_R1 in state= *llc\_state, llc2\_connection, network network*

**Description:** A Receive Not Ready frame received FSM event occurred on an LLC2 connection. The frame was a response with the poll bit on.

---

**LLC.084**

**Level:** P-TRACE

**Short Syntax:** LLC.084 ev=REJ\_C0 in st= *llc\_state, llc2\_connection, nt network*

**Long Syntax:** LLC.084 event=REJ\_C0 in state= *llc\_state, llc2\_connection, network network*

**Description:** A Reject frame received FSM event occurred on an LLC2 connection. The frame was a command with the poll bit off.

---

**LLC.085**

**Level:** P-TRACE

**Short Syntax:** LLC.085 ev=REJ\_C1 in st= *llc\_state, llc2\_connection, nt network*

**Long Syntax:** LLC.085 event=REJ\_C1 in state= *llc\_state, llc2\_connection, network network*

**Description:** A Reject frame received FSM event occurred on an LLC2 connection. The frame was a command with the poll bit on.

---

**LLC.086**

**Level:** P-TRACE

**Short Syntax:** LLC.086 ev=REJ\_R0 in st= *llc\_state, llc2\_connection, nt network*

**Long Syntax:** LLC.086 event=REJ\_R0 in state= *llc\_state, llc2\_connection, network network*

**Description:** A Reject frame received FSM event occurred on an LLC2 connection. The frame was a response with the poll bit off.

---

**LLC.087**

**Level:** P-TRACE

**Short Syntax:** LLC.087 ev=REJ\_R1 in st= *llc\_state, llc2\_connection, nt network*

**Long Syntax:** LLC.087 event=REJ\_R1 in state= *llc\_state, llc2\_connection, network network*

**Description:** A Reject frame received FSM event occurred on an LLC2 connection. The frame was a response with the poll bit on.

---

**LLC.088**

**Level:** CI-ERROR

**Short Syntax:** LLC.088 ev=UA\_R0 in st= *llc\_state, llc2\_connection, nt network*

**Long Syntax:** LLC.088 event=UA\_R0 in state= *llc\_state, llc2\_connection, network network*

**Description:** An Unnumbered Acknowledgement frame received FSM event occurred on an LLC2 connection. The frame was a response with the poll bit off.

---

**LLC.089****Level:** CI-ERROR**Short Syntax:** LLC.089 ev=UA\_R0 in st= *llc\_state, llc2\_connection, nt network***Long Syntax:** LLC.089 event=UA\_R0 in state= *llc\_state, llc2\_connection, network network***Description:** An Unnumbered Acknowledgement frame received FSM event occurred on an LLC2 connection. The frame was a response with the poll bit on.

---

**LLC.090****Level:** CI-ERROR**Short Syntax:** LLC.090 ev=DISC\_C0 in st= *llc\_state, llc2\_connection, nt network***Long Syntax:** LLC.090 event=DISC\_C0 in state= *llc\_state, llc2\_connection, network network***Description:** A Disconnect frame received FSM event occurred on an LLC2 connection. The frame was a command with the poll bit off.

---

**LLC.091****Level:** CI-ERROR**Short Syntax:** LLC.091 ev=DISC\_C1 in st= *llc\_state, llc2\_connection, nt network***Long Syntax:** LLC.091 event=DISC\_C1 in state= *llc\_state, llc2\_connection, network network***Description:** A Disconnect frame received FSM event occurred on an LLC2 connection. The frame was a command with the poll bit on.

---

**LLC.092****Level:** CI-ERROR**Short Syntax:** LLC.092 ev=DM\_R0 in st= *llc\_state, llc2\_connection, nt network***Long Syntax:** LLC.092 event=DM\_R0 in state= *llc\_state, llc2\_connection, network network***Description:** A Disconnected Mode frame received FSM event occurred on an LLC2 connection. The frame was a response with the poll bit off.

---

**LLC.093****Level:** CI-ERROR**Short Syntax:** LLC.093 ev=DM\_R1 in st= *llc\_state, llc2\_connection, nt network***Long Syntax:** LLC.093 event=DM\_R1 in state= *llc\_state, llc2\_connection, network network***Description:** A Disconnected Mode frame received FSM event occurred on an LLC2 connection. The frame was a response with the poll bit on.

---

**LLC.094****Level:** CI-ERROR**Short Syntax:** LLC.094 ev=FRMR\_R0 in st= *llc\_state, llc2\_connection, nt network***Long Syntax:** LLC.094 event=FRMR\_R0 in state= *llc\_state, llc2\_connection, network network***Description:** A Frame Reject frame received FSM event occurred on an LLC2 connection. The frame was a response with the poll bit off.

---

**LLC.095**

**Level:** CI-ERROR

**Short Syntax:** LLC.095 ev=FRMR\_R1 in st= *llc\_state, llc2\_connection*, nt *network*

**Long Syntax:** LLC.095 event=FRMR\_R1 in state= *llc\_state, llc2\_connection*, network *network*

**Description:** A Frame Reject frame received FSM event occurred on an LLC2 connection. The frame was a response with the poll bit on.

---

**LLC.096**

**Level:** CI-ERROR

**Short Syntax:** LLC.096 ev=BAD\_FRAME\_0 in st= *llc\_state, llc2\_connection*, nt *network*

**Long Syntax:** LLC.096 event=BAD\_FRAME\_0 in state= *llc\_state, llc2\_connection*, network *network*

**Description:** A badly formatted frame received FSM event occurred on an LLC2 connection. The frame usually causes a frame reject. The badly formatted frame had the poll bit off.

**Cause:** The other end of the connection generated an illegal LLC frame.

**Action:** If the problem persists, fix the other end of the connection.

---

**LLC.097**

**Level:** CI-ERROR

**Short Syntax:** LLC.097 ev=BAD\_FRAME\_1 in st= *llc\_state, llc2\_connection*, nt *network*

**Long Syntax:** LLC.097 event=BAD\_FRAME\_1 in state= *llc\_state, llc2\_connection*, network *network*

**Description:** A badly formatted frame received FSM event occurred on an LLC2 connection. The frame usually causes an FRMR to be generated. It had the poll bit on.

**Cause:** The other end of the connection generated an illegal LLC frame.

**Action:** If the problem persists, fix the other end of the connection.

---

**LLC.098**

**Level:** CI-ERROR

**Short Syntax:** LLC.098 ev=SABME\_C0 in st= *llc\_state, llc2\_connection*, nt *network*

**Long Syntax:** LLC.098 event=SABME\_C0 in state= *llc\_state, llc2\_connection*, network *network*

**Description:** A Set Asynchronous Balanced Mode Extended frame received FSM event occurred on an LLC2 connection. The frame was a command with the poll bit off.

---

**LLC.099**

**Level:** CI-ERROR

**Short Syntax:** LLC.099 ev=SABME\_C1 in st= *llc\_state, llc2\_connection*, nt *network*

**Long Syntax:** LLC.099 event=SABME\_C1 in state= *llc\_state, llc2\_connection*, network *network*

**Description:** A Set Asynchronous Balanced Mode Extended frame received FSM event occurred on an LLC2 connection. The frame was a command with the poll bit on.

---

**LLC.100****Level:** C-INFO**Short Syntax:** LLC.100 ev=FLOW\_REQ\_ON in st= *llc\_state, llc2\_connection*, nt *network***Long Syntax:** LLC.100 event=FLOW\_REQ\_ON in state= *llc\_state, llc2\_connection*, network *network***Description:** This is a FLOW\_REQ\_ON FSM event. An LLC2 user requested to turn off the local busy condition.

---

**LLC.101****Level:** C-INFO**Short Syntax:** LLC.101 ev=FLOW\_REQ\_OFF in st= *llc\_state, llc2\_connection*, nt *network***Long Syntax:** LLC.101 event=FLOW\_REQ\_OFF in state= *llc\_state, llc2\_connection*, network *network***Description:** This is a FLOW\_REQ\_OFF FSM event. An LLC2 user requested to turn on the local busy condition.

---

**LLC.102****Level:** C-INFO**Short Syntax:** LLC.102 ev=UNKNOWN in st= *llc\_state, llc2\_connection*, nt *network***Long Syntax:** LLC.102 event=UNKNOWN in state= *llc\_state, llc2\_connection*, network *network***Description:** An unknown FSM event occurred on an LLC2 connection. If this occurs, report it to customer service.

---

**LLC.103****Level:** CI-ERROR**Short Syntax:** LLC.103 Up evt CONN\_IND args *user\_value/ event\_reason* on *llc2-conn***Long Syntax:** LLC.103 Upcall user event CONN\_IND *user\_value event\_reason* on *llc2-conn***Description:** LLC2 is making a CONN\_IND, connection indication, upcall to the application. The user value is the user-supplied value for the session. This event reason is not meaningful.

---

**LLC.104****Level:** CI-ERROR**Short Syntax:** LLC.104 Up evt CONN\_IND\_PASS args *user\_value/ event\_reason* on *llc2-conn***Long Syntax:** LLC.104 Upcall user event CONN\_IND\_PASS *user\_value event\_reason* on *llc2-conn***Description:** LLC2 is making a CONN\_IND\_PASS, connection indication passive, upcall to the application. The user value is the user-supplied value for the SAP. This event reason is not meaningful.

---

**LLC.105**

**Level:** CI-ERROR

**Short Syntax:** LLC.105 Up evt CONN\_CONFIRM args *user\_value/ event\_reason* on *llc2-conn*

**Long Syntax:** LLC.105 Upcall user event CONN\_CONFIRM *user\_value event\_reason* on *llc2-conn*

**Description:** LLC2 is making a CONN\_CONFIRM, connection confirm, upcall to the application. The user value is the user-supplied value for the session. This event reason is not meaningful.

---

**LLC.106**

**Level:** CI-ERROR

**Short Syntax:** LLC.106 Up evt DISC\_IND args *user\_value/ event\_reason* on *llc2-conn*

**Long Syntax:** LLC.106 Upcall user event DISC\_IND *user\_value event\_reason* on *llc2-conn*

**Description:** LLC2 is making a DISC\_IND, disconnect indication, upcall to the application. The user value is the user-supplied value for the session. The event reason is local term (disconnecting), which means that the local LLC2 is in the process of disconnecting the session and will be making one more upcall, a disconnect confirm upcall, when the session completed disconnects.

---

**LLC.107**

**Level:** CI-ERROR

**Short Syntax:** LLC.107 Up evt DISC\_IND args *user\_value/ event\_reason* on *llc2-conn*

**Long Syntax:** LLC.107 Upcall user event DISC\_IND *user\_value event\_reason* on *llc2-conn*

**Description:** LLC2 is making a DISC\_IND, disconnect indication, upcall to the application. The user value is the user-supplied value for the session. The event reason is local term (disconnected), which means that the local LLC2 completely disconnected the session and will NOT be making any more upcalls for this session.

---

**LLC.108**

**Level:** CI-ERROR

**Short Syntax:** LLC.108 Up evt DISC\_IND args *user\_value/ event\_reason* on *llc2-conn*

**Long Syntax:** LLC.108 Upcall user event DISC\_IND *user\_value event\_reason* on *llc2-conn*

**Description:** LLC2 is making a DISC\_IND, disconnect indication, upcall to the application. The user value is the user-supplied value for the session. The event reason is remote term, which means that the remote LLC2 terminated the session. There will NOT be any more upcalls for this session.

---

**LLC.109**

**Level:** CI-ERROR

**Short Syntax:** LLC.109 Up evt DISC\_IND args *user\_value/ event\_reason* on *llc2-conn*

**Long Syntax:** LLC.109 Upcall user event DISC\_IND *user\_value event\_reason* on *llc2-conn*

**Description:** LLC2 is making a DISC\_IND, disconnect indication, upcall to the application. The user value is the user-supplied value for the session. The event reason is connection refused, which means that the remote LLC2 terminated the session. There will NOT be any more upcalls for this session.

---

**LLC.110****Level:** CI-ERROR**Short Syntax:** LLC.110 Up evt RESET\_IND args *user\_value/ event\_reason* on *llc2-conn***Long Syntax:** LLC.110 Upcall user event RESET\_IND *user\_value event\_reason* on *llc2-conn***Description:** LLC2 is making a RESET\_IND, reset indication, upcall to the application. The user value is the user-supplied value for the session. The event reason is one of the following: local reset, remote reset, frmr rcvd, or frmr sent.

---

**LLC.111****Level:** CI-ERROR**Short Syntax:** LLC.111 Up evt RESET\_CONF args *user\_value/ event\_reason* on *llc2-conn***Long Syntax:** LLC.111 Upcall user event RESET\_CONF *user\_value event\_reason* on *llc2-conn***Description:** LLC2 is making a RESET\_CONF, reset indication, upcall to the application. The user value is the user-supplied value for the session. This event reason is not meaningful.

---

**LLC.112****Level:** C-INFO**Short Syntax:** LLC.112 Up evt FLOW\_IND args *user\_value/ event\_reason* on *llc2-conn***Long Syntax:** LLC.112 Upcall user event FLOW\_IND *user\_value event\_reason* on *llc2-conn***Description:** LLC2 is making a FLOW\_IND, reset indication, upcall to the application. The user value is the user-supplied value for the session. The event reason is flow off, meaning the application should try not to send any more data.

---

**LLC.113****Level:** C-INFO**Short Syntax:** LLC.113 Up evt FLOW\_IND args *user\_value/ event\_reason* on *llc2-conn***Long Syntax:** LLC.113 Upcall user event FLOW\_IND *user\_value event\_reason* on *llc2-conn***Description:** LLC2 is making a FLOW\_IND, reset indication, upcall to the application. The user value is the user-supplied value for the session. The event reason is flow on, meaning the application can send data now.

---

**LLC.114****Level:** CI-ERROR**Short Syntax:** LLC.114 Up evt DISC\_CONFIRM args *user\_value/ event\_reason* on *llc2-conn***Long Syntax:** LLC.114 Upcall user event DISC\_CONFIRM *user\_value event\_reason* on *llc2-conn***Description:** The LLC2 is making a DISC\_CONFIRM, disconnect confirm, upcall to the application. The user value is the user-supplied value for the session. This event reason is not meaningful. There will NOT be any more upcalls for this session.

---

**LLC.115**

**Level:** CI-ERROR

**Short Syntax:** LLC.115 prim OPEN\_SAP sap *SAP\_value* on nt *network*

**Long Syntax:** LLC.115 user primitive OPEN\_SAP sap *SAP\_value* on network *network*

**Description:** The OPEN\_SAP user-primitive was called.

---

**LLC.116**

**Level:** CI-ERROR

**Short Syntax:** LLC.116 prim CLOSE\_SAP sap *SAP\_value* on nt *network*

**Long Syntax:** LLC.116 user primitive CLOSE\_SAP sap *SAP\_value* on network *network*

**Description:** The CLOSE\_SAP user-primitive was called.

---

**LLC.117**

**Level:** CI-ERROR

**Short Syntax:** LLC.117 prim CLOSE\_SAP\_FORCED sap *SAP\_value* on nt *network*

**Long Syntax:** LLC.117 user primitive CLOSE\_SAP\_FORCED sap *SAP\_value* on network *network*

**Description:** The CLOSE\_SAP\_FORCED user-primitive was called.

---

**LLC.118**

**Level:** CI-ERROR

**Short Syntax:** LLC.118 prim MODIFY\_SAP sap *SAP\_value* on nt *network*

**Long Syntax:** LLC.118 user primitive MODIFY\_SAP sap *SAP\_value* on network *network*

**Description:** The MODIFY\_SAP user-primitive was called.

---

**LLC.119**

**Level:** CI-ERROR

**Short Syntax:** LLC.119 prim OPEN\_STATION sap *SAP\_value* on nt *network*

**Long Syntax:** LLC.119 user primitive OPEN\_STATION sap *SAP\_value* on network *network*

**Description:** The OPEN\_STATION user-primitive was called.

---

**LLC.120**

**Level:** CI-ERROR

**Short Syntax:** LLC.120 prim CLOSE\_STATION, *llc2\_connection*, nt *network*

**Long Syntax:** LLC.120 primitive CLOSE\_STATION, *llc2\_connection*, network *network*

**Description:** A CLOSE\_STATION user-primitive was called.

---

**LLC.121**

**Level:** CI-ERROR

**Short Syntax:** LLC.121 prim CLOSE\_STATION\_FORCED, *llc2\_connection*, nt *network*

**Long Syntax:** LLC.121 primitive CLOSE\_STATION\_FORCED, *llc2\_connection*, network *network*

**Description:** A CLOSE\_STATION\_FORCED user-primitive was called.



---

**LLC.122****Level:** CI-ERROR**Short Syntax:** LLC.122 prim CONNECT\_REQUEST, *llc2\_connection*, nt *network***Long Syntax:** LLC.122 primitive CONNECT\_REQUEST, *llc2\_connection*, network *network***Description:** A CONNECT\_REQUEST user-primitive was called.

---

**LLC.123****Level:** CI-ERROR**Short Syntax:** LLC.123 prim CONNECT\_RESPONSE, *llc2\_connection*, nt *network***Long Syntax:** LLC.123 primitive CONNECT\_RESPONSE, *llc2\_connection*, network *network***Description:** A CONNECT\_RESPONSE user-primitive was called.

---

**LLC.124****Level:** CI-ERROR**Short Syntax:** LLC.124 prim DISCONNECT\_REQUEST, *llc2\_connection*, nt *network***Long Syntax:** LLC.124 primitive DISCONNECT\_REQUEST, *llc2\_connection*, network *network***Description:** A DISCONNECT\_REQUEST user-primitive was called.

---

**LLC.125****Level:** CI-ERROR**Short Syntax:** LLC.125 prim RESET\_REQUEST, *llc2\_connection*, nt *network***Long Syntax:** LLC.125 primitive RESET\_REQUEST, *llc2\_connection*, network *network***Description:** A RESET\_REQUEST user-primitive was called.

---

**LLC.126****Level:** CI-ERROR**Short Syntax:** LLC.126 prim RESET\_RESPONSE, *llc2\_connection*, nt *network***Long Syntax:** LLC.126 primitive RESET\_RESPONSE, *llc2\_connection*, network *network***Description:** A RESET\_RESPONSE user-primitive was called.

---

**LLC.127****Level:** CI-ERROR**Short Syntax:** LLC.127 prim ABORT\_STATION, *llc2\_connection*, nt *network***Long Syntax:** LLC.127 primitive ABORT\_STATION, *llc2\_connection*, network *network***Description:** An ABORT\_STATION user-primitive was called that silently closed the station.

---

**LLC.128****Level:** C-INFO**Short Syntax:** LLC.128 prim FLOW\_REQ OFF, *llc2\_connection*, nt *network***Long Syntax:** LLC.128 primitive FLOW\_REQ OFF, *llc2\_connection*, network *network***Description:** A FLOW\_REQ user-primitive was called to request flow off.

---

**LLC.129**

**Level:** C-INFO

**Short Syntax:** LLC.129 prim FLOW\_REQ ON, *llc2\_connection*, nt *network*

**Long Syntax:** LLC.129 primitive FLOW\_REQ ON, *llc2\_connection*, network *network*

**Description:** A FLOW\_REQ user-primitive was called to request flow on.

---

**LLC.130**

**Level:** U-INFO

**Short Syntax:** LLC.130 UI frm refused *llc2\_connection*, nt *network*

**Long Syntax:** LLC.130 UI frame refused, *llc2\_connection*, network *network*

**Description:** The local application within the router refused the UI frame. It passed the frame on to the bridge code.

**Cause:** The frame was not the type the local application wanted to handle.

**Action:** None.

---

**LLC.131**

**Level:** C-INFO

**Short Syntax:** LLC.131 LLC loopback invoked *src\_mac-> dst\_mac*, saps *src\_sap-> dst\_sap*, nt *network*

**Long Syntax:** LLC.131 LLC loopback invoked, *src\_mac-> dst\_mac*, saps *src\_sap-> dst\_sap*, network *network*

**Description:** Loopback processing has been invoked to route frames within the router.

---

**LLC.132**

**Level:** C-INFO

**Short Syntax:** LLC.132 Dest SCB not found *src\_mac-> dst\_mac*, saps *src\_sap-> dst\_sap*, nt *network*

**Long Syntax:** LLC.132 Destination SCB not found, *src\_mac-> dst\_mac*, saps *src\_sap-> dst\_sap*, network *network*

**Description:** Loopback Processing has not found the Session Control Block for the destination.

**Cause:** The destination application may not have done an open station. The destination application may have gone down.

**Action:** None.

---

**LLC.133**

**Level:** C-INFO

**Short Syntax:** LLC.133 Loopback CONNECT, *src\_mac-> dst\_mac*, saps *src\_sap-> dst\_sap*, nt *src\_net*, nt *dst\_net*

**Long Syntax:** LLC.133 Loopback CONNECT, *src\_mac-> dst\_mac*, saps *src\_sap-> dst\_sap*, network *src\_net*, network *dst\_net*

**Description:** Connect in is being sent from origin net to destination net.

---

**LLC.134****Level:** C-INFO**Short Syntax:** LLC.134 Loopback CONNECT Rsp, *src\_mac-> dst\_mac*, saps *src\_sap-> dst\_sap*, nt *src\_net*, nt *dst\_net***Long Syntax:** LLC.134 Loopback CONNECT Response, *src\_mac-> dst\_mac*, saps *src\_sap-> dst\_sap*, network *src\_net*, nt *dst\_net***Description:** Connect response is being sent from origin net to destination net.

---

**LLC.135****Level:** C-INFO**Short Syntax:** LLC.135 Loopback DISCONNECT, *src\_mac-> dst\_mac*, saps *src\_sap-> dst\_sap*, nt *src\_net*, nt *dst\_net***Long Syntax:** LLC.135 Loopback DISCONNECT, *src\_mac-> dst\_mac*, saps *src\_sap-> dst\_sap*, nt *src\_net*, nt *dst\_net***Description:** Disconnect is being sent from origin net to destination net.

---

**LLC.136****Level:** C-INFO**Short Syntax:** LLC.136 Loopback DISCONNECT Rsp, *src\_mac-> dst\_mac*, saps *src\_sap-> dst\_sap*, nt *src\_net*, nt *dst\_net***Long Syntax:** LLC.136 Loopback DISCONNECT Response, *src\_mac-> dst\_mac*, saps *src\_sap-> dst\_sap*, nt *src\_net*, nt *dst\_net***Description:** Disconnect response is being sent from origin net to destination net.

---

**LLC.137****Level:** C-INFO**Short Syntax:** LLC.137 Loopback RESET, *src\_mac-> dst\_mac*, saps *src\_sap-> dst\_sap*, nt *src\_net*, nt *dst\_net***Long Syntax:** LLC.137 Loopback RESET, *src\_mac-> dst\_mac*, saps *src\_sap-> dst\_sap*, nt *src\_net*, nt *dst\_net***Description:** Reset is being sent from origin net to destination net.

---

**LLC.138****Level:** C-INFO**Short Syntax:** LLC.138 Loopback RESET Rsp, *src\_mac-> dst\_mac*, saps *src\_sap-> dst\_sap*, nt *src\_net*, nt *dst\_net***Long Syntax:** LLC.138 Loopback RESET Response, *src\_mac-> dst\_mac*, saps *src\_sap-> dst\_sap*, nt *src\_net*, nt *dst\_net***Description:** Reset response is being sent from origin net to destination net.

---

**LLC.139**

**Level:** C-INFO

**Short Syntax:** LLC.139 Loopback FLOW ON, *src\_mac-> dst\_mac*, saps *src\_sap-> dst\_sap*, nt *src\_net*, nt *dst\_net*

**Long Syntax:** LLC.139 Loopback FLOW ON, *src\_mac-> dst\_mac*, saps *src\_sap-> dst\_sap*, network *src\_net*, nt *dst\_net*

**Description:** Flow on is being sent from origin net to destination net.

---

**LLC.140**

**Level:** C-INFO

**Short Syntax:** LLC.140 Loopback FLOW OFF, *src\_mac-> dst\_mac*, saps *src\_sap-> dst\_sap*, nt *src\_net*, nt *dst\_net*

**Long Syntax:** LLC.140 Loopback FLOW OFF, *src\_mac-> dst\_mac*, saps *src\_sap-> dst\_sap*, network *src\_net*, nt *dst\_net*

**Description:** Flow off is being sent from origin net to destination net.

---

**LLC.141**

**Level:** C-INFO

**Short Syntax:** LLC.141 Loopback FLOW OFF Data, st *state*,, busy *busy\_flag*,, qnum *qnum*,, nt *src\_net*

**Long Syntax:** LLC.141 Loopback FLOW OFF Data, state *state*,, busy *busy\_flag*,, tr\_queue\_num *qnum*,, network *src\_net*

**Description:** Flow off data to get the exact status of the application sending flow off

---

**LLC.142**

**Level:** C-INFO

**Short Syntax:** LLC.142 Loopback FLOW ON Data, st *state*,, busy *busy\_flag*,, qnum *qnum*,, nt *src\_net*

**Long Syntax:** LLC.142 Loopback FLOW ON Data, state *state*,, busy *busy\_flag*,, tr\_queue\_num *qnum*,, network *src\_net*

**Description:** Flow on data to get the exact status of the application sending flow on

---

**LLC.143**

**Level:** C-INFO

**Short Syntax:** LLC.143 LLC Busy No Resource, st *state*,, busy *busy\_flag*,, num *qnum*,, nt *src\_net*

**Long Syntax:** LLC.143 LLC Busy No Resource, state *state*,, busy *busy\_flag*,, num *qnum*,, network *src\_net*

**Description:** Exceeded Max IORB in queue, data to get the exact status of the application

---

**LLC.144****Level:** C-INFO**Short Syntax:** LLC.144 Loopback Net Not Found, *src\_mac-> dst\_mac*, saps *src\_sap-> dst\_sap*, nt *network***Long Syntax:** LLC.144 Loopback Net Not Found, *src\_mac-> dst\_mac*, saps *src\_sap-> dst\_sap*, network *network***Description:** Net structure for the loopback destination net has not been found.

---

**LLC.145****Level:** C-INFO**Short Syntax:** LLC.145 Loopback Dest Matching SAP Not Found, *src\_mac-> dst\_mac*, saps *src\_sap-> dst\_sap*, nt *network***Long Syntax:** LLC.145 Loopback Dest Matching SAP Not Found, *src\_mac-> dst\_mac*, saps *src\_sap-> dst\_sap*, network *network***Description:** Sap structure for the loopback destination sap has not been found.

---

**LLC.146****Level:** C-INFO**Short Syntax:** LLC.146 Loopback Connect Data, st *state,, dest\_st dest\_st,, nt src\_net,, nt dst\_net***Long Syntax:** LLC.146 Loopback Connect Data, state *state,, dest\_st dest\_st,, network src\_net,, network dst\_net***Description:** Loopback Connect Data

---

**LLC.147****Level:** C-INFO**Short Syntax:** LLC.147 Loopback Connect Failed, st *state,, dest\_st dest\_st,, nt src\_net,, nt dst\_net***Long Syntax:** LLC.147 Loopback Connect Failed, state *state,, dest\_st dest\_st,, network src\_net,, network dst\_net***Description:** Loopback Connect Failed

---

**LLC.148****Level:** C-INFO**Short Syntax:** LLC.148 Loopback Send Failed, st *state,, dest\_st dest\_st,, nt src\_net,, nt dst\_net***Long Syntax:** LLC.148 Loopback Send Failed, state *state,, dest\_st dest\_st,, network src\_net,, network dst\_net***Description:** Loopback Send Failed



---

## Appendix E. Notices

References in this publication to IBM products, programs, or services do not imply that IBM intends to make these available in all countries in which IBM operates. Any reference to an IBM product, program, or service is not intended to state or imply that only IBM's product, program, or service may be used. Subject to IBM's valid intellectual property, or other legally protectable rights, any functionally equivalent product, program, or service that does not infringe any of IBM's intellectual property rights may be used instead of the IBM product, program, or service. The evaluation and verification of operation in conjunction with other products, except those expressly designated by IBM, are the user's responsibility.

IBM may have patents or pending patent applications covering subject matter in this document. The furnishing of this document does not give you any license to these patents. You can send license inquiries, in writing, to:

IBM Director of Licensing  
IBM Corporation  
500 Columbus Avenue  
Thornwood, NY 10594 USA

---

## Electronic Emission Notices

### Federal Communications Commission (FCC) Statement

**Note:** This equipment has been tested and found to comply with the limits for a Class A digital device, pursuant to Part 15 of the FCC Rules. These limits are designed to provide reasonable protection against harmful interference when the equipment is operated in a commercial environment. This equipment generates, uses, and can radiate radio frequency energy and, if not installed and used in accordance with the instruction manual, may cause harmful interference to radio communications. Operation of this equipment in a residential area is likely to cause harmful interference, in which case the user will be required to correct the interference at his own expense.

Properly shielded and grounded cables and connectors must be used in order to meet FCC emission limits. IBM is not responsible for any radio or television interference caused by using other than recommended cables and connectors or by unauthorized changes or modifications to this equipment. Unauthorized changes or modifications could void the user's authority to operate the equipment.

This device complies with Part 15 of the FCC Rules. Operation is subject to the following two conditions: (1) this device may not cause harmful interference, and (2) this device must accept any interference received, including interference that may cause undesired operation.

### **Industry Canada Class A Emission Compliance Statement**

This Class A digital apparatus meets the requirements of the Canadian Interference-Causing Equipment Regulations.

### **Avis de conformité aux normes d'Industrie Canada.**

Cet appareil numérique de la classe A respecte toutes les exigences du Règlement sur le matériel brouilleur du Canada.

### **European Community (EC) Mark of Conformity Statement**

This product is in conformity with the protection requirements of EU Council Directive 89/336/EEC on the approximation of the laws of the Member States relating to electromagnetic compatibility. IBM cannot accept responsibility for any failure to satisfy the protection requirements resulting from a non-recommended modification of the product, including the fitting of non-IBM option cards.

This product has been tested and found to comply with the limits for Class A Information Technology Equipment according to CISPR 22/European Standard EN 55022. The limits for Class A equipment were derived for commercial and industrial environments to provide reasonable protection against interference with licensed communication equipment. **Warning:** This is a Class A product. In a domestic environment this product may cause radio interference in which case the user may be required to take adequate measures.

Dieses Gerät ist berechtigt in Übereinstimmung mit dem deutschen EMVG vom 9.Nov.92 das EG-Konformitätszeichen zu führen. Der Aussteller der Konformitätserklärung ist die IBM RTP; PO Box 12195; Research Triangle Park, North Carolina 27709-9990; USA.

Dieses Gerät erfüllt die Bedingungen der EN 55022 Klasse A. Für diese Klasse von Geräten gilt folgende Bestimmung nach dem EMVG: Geräte dürfen an Orten, für die sie nicht ausreichend entstört sind, nur mit besonderer Genehmigung des Bundesministers für Post und Telekommunikation oder des Bundesamtes für Post und Telekommunikation betrieben werden. Die Genehmigung wird erteilt, wenn keine elektromagnetischen Störungen zu erwarten sind. Auszug aus dem EMVG vom 9.Nov.92, Para.3, Abs.4)

#### Hinwies:

Dieses Genehmigungsverfahren ist von der Deutschen Bundespost noch nicht veröffentlicht worden.

### **Japanese Voluntary Control Council for Interference (VCCI) Statement**

This equipment is Class 1 Equipment (information equipment to be used in commercial and industrial districts) which is in conformance with the standard set by the Voluntary Control for Interference Council by Data Processing Equipment and Electronic Office Machines (VCCI) with an aim to prevent radio interference in commercial and industrial districts. This equipment could cause interference to radio and television receivers when used in and around residential districts. Please handle the equipment properly according to the instruction manual.



### 情報処理装置等電波障害自主規制協議会 (VCCI) 表示

この装置は、第一種情報装置(商工業地域において使用されるべき情報装置)で商工業地域での電波障害防止を目的とした情報処理装置等電波障害自主規制協議会(VCCI)基準に適合しております。

従って、住宅地域またはその隣接した地域で使用すると、ラジオ、テレビジョン受信機等に受信障害を与えることがあります。

取扱説明書に従って正しい取り扱いをして下さい。

### Korean Communications Statement

Please note that this device has been approved for business purpose with regard to electromagnetic interference. If you find this is not suitable for your use, you may exchange it for a non-business purpose one.

대한민국 통신문

이 기기는 업무용으로 전자장해능정을 받은 기기이며, 이온나 X매자 또는 사용자는 이 점을 주의하시기 바라며, 만약 잘못 구입하였을 때에는 구입한 곳에서 비업무용으로 교환하시기 바랍니다.



## Appendix F. Safety Information

 **Danger:** Before you begin to install this product, read the safety information in *Caution: Safety Information—Read This First*, SD21-0030. This booklet describes safe procedures for cabling and plugging in electrical equipment.

 **Gevaar:** Voordat u begint met de installatie van dit produkt, moet u eerst de veiligheidsinstructies lezen in de brochure *PAS OP! Veiligheidsinstructies—Lees dit eerst*, SD21-0030. Hierin wordt beschreven hoe u elektrische apparatuur op een veilige manier moet bekabelen en aansluiten.

 **Danger:** Avant de procéder à l'installation de ce produit, lisez d'abord les consignes de sécurité dans la brochure *ATTENTION: Consignes de sécurité—A lire au préalable*, SD21-0030. Cette brochure décrit les procédures pour câbler et connecter les appareils électriques en toute sécurité.

 **Perigo:** Antes de começar a instalar este produto, leia as informações de segurança contidas em *Cuidado: Informações Sobre Segurança—Leia Isto Primeiro*, SD21-0030. Esse folheto descreve procedimentos de segurança para a instalação de cabos e conexões em equipamentos elétricos.



危險：安裝本產品之前，請先閱讀  
"Caution: Safety Information--Read  
This First" SD21-0030 手冊中所提  
供的安全注意事項。這本手冊將會說明  
使用電器設備的纜線及電源的安全程序。



Opasnost: Prije nego što počnete sa instalacijom produkta, pročitajte naputak o pravilima o sigurnom rukovanju u Upozorenje: Pravila o sigurnom rukovanju - Prvo pročitaj ovo, SD21-0030. Ovaj priručnik opisuje sigurnosne postupke za priključivanje kabela i priključivanje na električno napajanje.



**Upozornění:** než zahájíte instalaci tohoto produktu, přečtěte si nejprve bezpečnostní informace v pokynech „Bezpečnostní informace“ č. 21-0030. Tato brožurka popisuje bezpečnostní opatření pro kabeláž a zapojení elektrického zařízení.



**Fare!** Før du installerer dette produkt, skal du læse sikkerhedsforskrifterne i *NB: Sikkerhedsforskrifter—Læs dette først* SD21-0030. Vejledningen beskriver den fremgangsmåde, du skal bruge ved tilslutning af kabler og udstyr.



**Gevaar** Voordat u begint met het installeren van dit produkt, dient u eerst de veiligheidsrichtlijnen te lezen die zijn vermeld in de publikatie *Caution: Safety Information - Read This First*, SD21-0030. In dit boekje vindt u veilige procedures voor het aansluiten van elektrische apparatuur.



**VAARA:** Ennen kuin aloitat tämän tuotteen asennuksen, lue julkaisussa *Varoitus: Turvaohjeet—Lue tämä ensin*, SD21-0030, olevat turvaohjeet. Tässä kirjassessa on ohjeet siitä, miten sähkölaitteet kaapeloidaan ja kytketään turvallisesti.



**Danger :** Avant d'installer le présent produit, consultez le livret *Attention : Informations pour la sécurité — Lisez-moi d'abord*, SD21-0030, qui décrit les procédures à respecter pour effectuer les opérations de câblage et brancher les équipements électriques en toute sécurité.



**Vorsicht:** Bevor mit der Installation des Produktes begonnen wird, die Sicherheitshinweise in *Achtung: Sicherheitsinformationen—Bitte zuerst lesen*, IBM Form SD21-0030. Diese Veröffentlichung beschreibt die Sicherheitsvorkehrungen für das Verkabeln und Anschließen elektrischer Geräte.



**Vigyázat:** Mielőtt megkezdi a berendezés üzembe helyezését, olvassa el a *Caution: Safety Information— Read This First*, SD21-0030 könyvecskében leírt biztonsági információkat. Ez a könyv leírja, milyen biztonsági intézkedéseket kell megtenni az elektromos berendezés huzalozásakor illetve csatlakoztatásakor.



**Pericolo:** prima di iniziare l'installazione di questo prodotto, leggere le informazioni relative alla sicurezza riportate nell'opuscolo *Attenzione: Informazioni di sicurezza — Prime informazioni da leggere* in cui sono descritte le procedure per il cablaggio ed il collegamento di apparecchiature elettriche.



危険： 導入作業を開始する前に、安全に関する小冊子SD21-0030 の「最初にお読みください」(Read This First)の項をお読みください。この小冊子は、電気機器の安全な配線と接続の手順について説明しています。



위험: 이 제품을 설치하기 전에 반드시  
"주의: 안전 정보-시작하기 전에"  
(SD21-0030) 에 있는 안전 정보를  
읽으십시오.



**Fare:** Før du begynner å installere dette produktet, må du lese sikkerhetsinformasjonen i *Advarsel: Sikkerhetsinformasjon — Les dette først*, SD21-0030 som beskriver sikkerhetsrutinene for kabling og tilkobling av elektrisk utstyr.



Uwaga:  
Przed rozpoczęciem instalacji produktu należy zapoznać się z instrukcją:  
"Caution: Safety Information - Read This First", SD21-0030.  
Zawiera ona warunki bezpieczeństwa przy podłączeniu do sieci elektrycznej i eksploatacji.



**Perigo:** Antes de iniciar a instalação deste produto, leia as informações de segurança *Cuidado: Informações de Segurança — Leia Primeiro*, SD21-0030. Este documento descreve como efectuar, de um modo seguro, as ligações eléctricas dos equipamentos.



**ОСТОРОЖНО:** Прежде чем устанавливать этот продукт, прочтите Инструкцию по технике безопасности в документе "Внимание: Инструкция по технике безопасности -- Прочсть в первую очередь", SD21-0030. В этой брошюре описаны безопасные способы кабирования и подключения электрического оборудования.



Nebezpečenstvo: Pred inštaláciou výrobku si prečítajte bezpečnostné predpisy v  
Výstraha: Bezpečnostné predpisy - Prečítaj ako prvé,  
SD21-0030. V tejto brožúrke sú opísané bezpečnostné postupy pre pripojenie elektrických zariadení.



Pozor: Preden začnete z inštalacijo tega produkta preberite poglavje: "Opozorilo: Informacije o varnem rokovanju-preberite pred uporabo," SD21-0030. To poglavje opisuje pravilne postopke za kabliranje,

## Safety Information



**Peligro:** Antes de empezar a instalar este producto, lea la información de seguridad en *Atención: Información de Seguridad — Lea Esto Primero*, SD21-0030. Este documento describe los procedimientos de seguridad para cablear y enchufar equipos eléctricos.



**Varning — livsfara:** Innan du börjar installera den här produkten bör du läsa säkerhetsinformationen i dokumentet *Varning: Säkerhetsföreskrifter— Läs detta först*, SD21-0030. Där beskrivs hur du på ett säkert sätt ansluter elektrisk utrustning.



危險：

開始安裝此產品之前，請先閱讀安全資訊。

注意：

請先閱讀 - 安全資訊 SD21-0030

此冊子說明插接電器設備之電纜線的安全程序。

---

## List of Abbreviations

|              |                                                           |                |                                                                               |
|--------------|-----------------------------------------------------------|----------------|-------------------------------------------------------------------------------|
| <b>ac</b>    | alternating current                                       | <b>E&amp;M</b> | earth & mark                                                                  |
| <b>ANSI</b>  | American National Standards Institute                     | <b>EIA</b>     | Electronic Industries Association                                             |
| <b>APC</b>   | alarm and power control (module)                          | <b>ELS</b>     | Event Logging System                                                          |
| <b>APPN</b>  | Advanced peer-to-peer networking                          | <b>EMIF</b>    | ESCON multiple image facility                                                 |
| <b>ARC</b>   | active remote connector                                   | <b>ESCON</b>   | Enterprise systems connection                                                 |
| <b>ATM</b>   | asynchronous transfer mode                                | <b>ESCD</b>    | ESCON Director                                                                |
| <b>AUI</b>   | Attachment unit interface.                                | <b>ESF</b>     | extended status flags                                                         |
| <b>BAN</b>   | boundary access node                                      | <b>FANB</b>    | fan box                                                                       |
| <b>Bc</b>    | committed burst size                                      | <b>FAT</b>     | file allocation table                                                         |
| <b>Be</b>    | excess burst size                                         | <b>FEP</b>     | front-end processor                                                           |
| <b>BMI</b>   | byte multiplexer interface                                | <b>FR</b>      | frame relay                                                                   |
| <b>bps</b>   | bits per second                                           | <b>FRAD</b>    | frame relay assembler/disassembler                                            |
| <b>BSC</b>   | binary synchronous communication                          | <b>FRFH</b>    | frame relay frame handler                                                     |
| <b>CAS</b>   | channel associated signaling                              | <b>FRTE</b>    | frame relay terminal equipment                                                |
| <b>CCS</b>   | (1) common channel signaling (2)<br>change control server | <b>FRU</b>     | field replaceable unit                                                        |
| <b>CDB</b>   | configuration database                                    | <b>FTP</b>     | File Transfer Protocol                                                        |
| <b>CES</b>   | circuit emulation service                                 | <b>Gbps</b>    | giga bits per second (1 000 000 000 bits<br>per second)                       |
| <b>CIR</b>   | committed information rate                                | <b>GUI</b>     | graphical user interface                                                      |
| <b>CLK</b>   | clock (module)                                            | <b>HDLC</b>    | high-level data link control                                                  |
| <b>CLKRD</b> | clock redrive (module)                                    | <b>HPFS</b>    | high performance file system                                                  |
| <b>CMIP</b>  | Common Management Information<br>Protocol                 | <b>HPR</b>     | High Performance Routing                                                      |
| <b>CMIS</b>  | Common Management Information<br>Services                 | <b>HS</b>      | high-speed                                                                    |
| <b>CMOT</b>  | CMIP over TCP/IP                                          | <b>HSA</b>     | high-speed adapter (module)                                                   |
| <b>CNM</b>   | communication network management                          | <b>HSDS</b>    | High Speed Digital Services                                                   |
| <b>CP</b>    | control point                                             | <b>HSSI</b>    | high-speed serial interface                                                   |
| <b>CRC</b>   | cyclic redundancy check                                   | <b>IEEE</b>    | Institute of Electrical and Electronics<br>Engineers                          |
| <b>dc</b>    | direct current                                            | <b>IDNX</b>    | Integrated Digital Network Exchange                                           |
| <b>DCD</b>   | dc distribution (module)                                  | <b>IP</b>      | Internet Protocol                                                             |
| <b>DCE</b>   | data circuit-terminating equipment                        | <b>IPX</b>     | Internetwork Packet Exchange.                                                 |
| <b>DC48</b>  | dc power input type -48V                                  | <b>ISDN</b>    | integrated-services digital network                                           |
| <b>DLCI</b>  | data link connection identifier                           | <b>ISM</b>     | IBM Solution Manager                                                          |
| <b>DLS</b>   | Data link switching.                                      | <b>ISMD</b>    | IBM Software Manufacturing and<br>Delivery                                    |
| <b>DLUR</b>  | Dependent Logical Unit Requester.                         | <b>ISO</b>     | International Organization for<br>Standardization.                            |
| <b>DTE</b>   | data terminal equipment                                   | <b>ISR</b>     | intermediate session routing                                                  |
| <b>DTMF</b>  | dual-tone modulation frequency                            | <b>ITU-T</b>   | International Telecommunication Union -<br>Telecommunication (replaces CCITT) |
| <b>DTR</b>   | data terminal ready                                       |                |                                                                               |

## List of Abbreviations

|              |                                                          |               |                                                  |
|--------------|----------------------------------------------------------|---------------|--------------------------------------------------|
| <b>Kbps</b>  | kilo bits per second (1000 bits per second)              | <b>PBX</b>    | private branch exchange                          |
| <b>kVA</b>   | kilovolt amperes                                         | <b>PCM</b>    | pulse code modulation                            |
| <b>LAN</b>   | local area network                                       | <b>PDH</b>    | plesiochronous digital hierarchy                 |
| <b>LAPD</b>  | link access procedure for D-channel                      | <b>PM</b>     | Presentation Manager                             |
| <b>LCB</b>   | line connection box                                      | <b>PNP</b>    | private numbering plan                           |
| <b>LCBB</b>  | line connection box, base                                | <b>PPP</b>    | point-to-point protocol                          |
| <b>LCBE</b>  | line connection box, expansion                           | <b>PRS</b>    | primary reference source                         |
| <b>LCEB</b>  | line connection enclosure, base                          | <b>PSN</b>    | public switched network                          |
| <b>LCEE</b>  | line connection enclosure, expansion                     | <b>PSTN</b>   | public switched telephone network                |
| <b>LCPB</b>  | line connection power, base                              | <b>PVC</b>    | permanent virtual circuit                        |
| <b>LCPE</b>  | line connection power, expansion                         | <b>PTM</b>    | packet transfer mode                             |
| <b>LCS</b>   | LAN Channel Station                                      | <b>QoS</b>    | quality of service                               |
| <b>LED</b>   | light-emitting diode                                     | <b>RETAIN</b> | Remote Technical Assistance Information Network  |
| <b>LIC</b>   | line interface coupler                                   | <b>RSC</b>    | Remote Support Center                            |
| <b>LMI</b>   | local management interface                               | <b>RSF</b>    | Remote Support Facility                          |
| <b>LP</b>    | logical partition                                        | <b>RT</b>     | real time                                        |
| <b>LPAR</b>  | logically partitioned                                    | <b>s</b>      | second                                           |
| <b>LS</b>    | low-speed                                                | <b>SAP</b>    | service access point                             |
| <b>LSA</b>   | Link Services Architecture                               | <b>SDH</b>    | synchronous digital hierarchy                    |
| <b>MAN</b>   | metropolitan area network                                | <b>SDLC</b>   | synchronous data link control                    |
| <b>MB</b>    | megabyte (1 048 576 bytes)                               | <b>SDT</b>    | structured data transfer                         |
| <b>Mbps</b>  | mega bits per second (1 000 000 bits per second)         | <b>SLA</b>    | serial link architecture                         |
| <b>MPC</b>   | Multi-Path Channel                                       | <b>SLIP</b>   | Serial Line Internet Protocol                    |
| <b>MPC+</b>  | High performance data transfer (HPDT) Multi-Path Channel | <b>SNA</b>    | Systems Network Architecture                     |
| <b>ms</b>    | millisecond (1/1000 second)                              | <b>SNMP</b>   | simple network management protocol               |
| <b>NAS</b>   | Nways Switch administration station                      | <b>SONET</b>  | synchronous optical network                      |
| <b>NBBS</b>  | Networking BroadBand Services (architecture)             | <b>SRC</b>    | system reference code                            |
| <b>NCT</b>   | Nways Switch Configuration Tool                          | <b>STM-1</b>  | synchronous transport module-1                   |
| <b>NDPS</b>  | non-disruptive path switching                            | <b>SW</b>     | switch (module)                                  |
| <b>NIC</b>   | Network Information Center                               | <b>SWRD</b>   | switch redrive (module)                          |
| <b>NMS</b>   | network management station                               | <b>TCP</b>    | Transmission Control Protocol                    |
| <b>NNI</b>   | network-to-network interface                             | <b>TCP/IP</b> | Transmission Control Protocol, Internet Protocol |
| <b>NRZ-1</b> | non-return-to-zero change-on-ones recording              | <b>TDM</b>    | time division multiplexing                       |
| <b>NSAP</b>  | network service address point                            | <b>UNI</b>    | user network interface (protocol)                |
| <b>NSC</b>   | Network Support Center                                   | <b>UTP</b>    | unshielded twisted pair                          |
| <b>NVDM</b>  | NetView Distribution Manager/6000                        | <b>Vac</b>    | volts alternating current                        |
| <b>OC</b>    | optical carrier                                          | <b>VPD</b>    | vital product data                               |
| <b>OSI</b>   | open systems interconnection                             | <b>VSA</b>    | voice server adapter (module)                    |
|              |                                                          | <b>VSE</b>    | voice server extension (module)                  |
|              |                                                          | <b>WAN</b>    | wide area network                                |



## Glossary

This glossary includes terms and definitions from:

- The *IBM Dictionary of Computing* (New York; McGraw-Hill, Inc., 1994).
- The *American National Standard Dictionary for Information Systems*, ANSI X3.172-1990, copyright 1990 by the American National Standards Institute (ANSI). Copies can be purchased from the American National Standards Institute, 1430 Broadway, New York, New York 10018. Definitions are identified by the symbol (A) after the definition.

### A

**A.** Ampere.

**active.** (1) Operational. (2) Pertaining to a node or device that is connected or is available for connection to another node or device.

**Advanced Peer-to-Peer Networking (APPN) network node.** A node that offers a broad range of end-user services and that can provide the following:

- Distributed directory services, including registration of its domain resources to a central directory server
- Topology database exchanges with other APPN network nodes, enabling network nodes throughout the network to select optimal routes for LU-LU sessions based on requested classes of service
- Session services for its local LUs and client end nodes
- Intermediate routing services within an APPN network

**agent.** A system that assumes an agent role.

**analog.** (1) Pertaining to data consisting of continuously variable physical quantities. (A)  
(2) Contrast with *digital*.

**AppleTalk.** A network protocol developed by Apple Computer, Inc. This protocol is used to interconnect network devices, which can be a mixture of Apple and non-Apple products.

**APPN node.** Advanced Peer-to-Peer Networking (APPN) node.

**asynchronous transfer mode (ATM).** A connection-oriented access service to transfer data, voice, and video on broadband networks at very high speeds. These traffic types are mixed together over the

available link bandwidth rather than being isolated into dedicated chunks of bandwidth.

The current ATM is for speeds of 155 Mbps and 622 Mbps but it will be capable of speeds in range of gigabits per second.

ATM divides all traffic into fixed-length cells, each containing 48 bytes of user data and five bytes of overhead, and manages the flow of these cells through the network.

**attachment unit interface (AUI).** In a local area network, the interface between the medium attachment unit and the data terminal equipment within a data station. (I) (A)

**autonomous system (AS).** A group of networks and routers that use the same interior gateway protocol and for which one administrative authority has responsibility.

### B

**bridge.** A functional unit that interconnects multiple LANs (locally or remotely) that use the same logical link control protocol but that can use different medium access control protocols. A bridge forwards a frame to another bridge based on the medium access control (MAC) address.

**bridging.** In LANs, the forwarding of a frame from one LAN segment to another. The destination is specified by the medium access control (MAC) sublayer address encoded in the destination address field of the frame header.

**broadband.** A large frequency band allowing different kinds of transmissions, such as coded voice, video, and data, at the same time.

### C

**CCITT.** International Telegraph and Telephone Consultative Committee. This was an organization of the International Telecommunication Union (ITU). On 1 March 1993 the ITU was reorganized, and responsibilities for standardization were placed in a subordinate organization named the Telecommunication Standardization Sector of the International Telecommunication Union (ITU-TS). "CCITT" continues to be used for recommendations that were approved before the reorganization.

**change control server (CCS).** A station that runs the NetView Distribution Manager/6000 to store the Nways Switch programs and control the code changes.

## Glossary

A change control server is connected to its management access Nways Switch via an Ethernet LAN.

**channelization.** The process of breaking the bandwidth on a communication line into a number of channels, possibly of different size. Also called *time division multiplexing* (TDM).

**circuit.** (1) One or more conductors through which an electric current can flow. See *physical circuit* and *virtual circuit*. (2) A logic device.

**circuit emulation service (CES).** An access service used to carry information between two devices with a constant rate input and output. The incoming data can be voice, video, fax, multimedia, or synchronous data in real-time.

**circuit switching.** (1) A process that, on demand, connects two or more data terminal equipment (DTEs) and permits the exclusive use of a data circuit between them until the connection is released. (I) (A)  
(2) Synonymous with *line switching*.

**code file.** A named set of records stored as a unit. An Nways Switch code file may include data or internal code. It is stored in a change control server.

**configuration.** (1) The manner in which the hardware and software of an information processing system are organized and interconnected. (T) (2) The devices and programs that make up a system, subsystem, or network.

**clock (CLK).** An Nways Switch module that monitors clocking signals in the line interface couplers according to the received clock references. It is optional and may have a backup.

**clock redrive (CLKRD).** A module of the 2216 Nways BroadBand Switch Model 501 that drives the signals from the Model 500 clock to the adapters of the Model 501. The clock redrive is optional and may have a backup.

**configuration database (CDB).** A database that stores the configuration parameters of one or several Nways Switches. It is prepared and updated using the Nways Switch Configuration Tool (NCT).

**connection.** In data communication, an association established between functional units for conveying information. (I) (A)

**control point (CP).** The logical resource of the Nways Switch that provides the network control functions of the NBBS architecture. It may have a backup.

**CU Logical Address.** The Control Unit address defined in the host for the 2216. This value is defined

in the host Input/Output Configuration Program (IOCP) by the CUADD statement on the CNTLUNIT macro instruction. The Control Unit Address must be unique for each logical partition defined on the same host.

## D

**data circuit.** (1) A pair of associated transmit and receive channels that provide a means of two-way data communication. (I) (2) See also *physical circuit* and *virtual circuit*.

### Notes:

1. Between data switching exchanges, the data circuit may include data circuit-terminating equipment (DCE), depending on the type of interface used at the data switching exchange.
2. Between a data station and a data switching exchange or data concentrator, the data circuit includes the data circuit-terminating equipment at the data station end, and may include equipment similar to a DCE at the data switching exchange or data concentrator location.

**data circuit-terminating equipment (DCE).** In a data station, the equipment that provides the signal conversion and coding between the data terminal equipment (DTE) and the line. (I)

### Notes:

1. The DCE may be separate equipment or an integral part of the DTE or of the intermediate equipment.
2. A DCE may perform other functions that are usually performed at the network end of the line.

**data link control (DLC).** A set of rules used by nodes on a data link (such as an SDLC link or a token ring) to accomplish an orderly exchange of information.

**data link switching (DLSw).** A method of transporting network protocols that use Institute of Electrical and Electronics Engineers (IEEE) 802.2 logical link control (LLC) type 2. Systems Network Architecture (SNA) and NetBIOS are examples of protocols that use LLC type 2.

**data terminal equipment (DTE).** That part of a data station that serves as a data source, data sink, or both. (I) (A)

**data terminal ready (DTR).** A signal to the modem used with the EIA 232 protocol.

**dependent LU requester (DLUR).** An APPN end node or an APPN network node that owns dependent LUs, but requests that a dependent LU server provide the SSCP services for those dependent LUs.

**device.** A mechanical, electrical, or electronic contrivance with a specific purpose.

**Device Address.** The unit address transmitted on the channel path to select a 2216 device. It is also referred to as subchannel number in S/370 I/O architecture. This value is defined in the host IOCP by the UNITADD statement on the CNTLUNIT macro instruction for the real device.

**digital.** (1) Pertaining to data that consist of digits. (T)  
(2) Pertaining to data in the form of digits. (A)  
(3) Contrast with *analog*.

**dummy module.** A cover inserted in the place of a module to ensure a correct air cooling inside an Nways Switch logic subrack. During normal operation, the dummy modules must not be removed.

## E

**EIA unit.** A unit of measure, established by the Electronic Industries Association, equal to 44.45 millimeters (1.75 inches).

**EIA 232.** In data communications, a specification of the Electronic Industries Association (EIA) that defines the interface between data terminal equipment (DTE) and data circuit-terminating equipment (DCE), using serial binary data interchange.

**Electronic Industries Association (EIA).** An organization of electronics manufacturers that advances the technological growth of the industry, represents the views of its members, and develops industry standards.

**encapsulation.** In communications, a technique used by layered protocols by which a layer adds control information to the protocol data unit (PDU) from the layer it supports. In this respect, the layer encapsulates the data from the supported layer. In the Internet suite of protocols, for example, a packet would contain control information from the physical layer, followed by control information from the network layer, followed by the application protocol data. See also *data link switching (DLSw)*.

**equivalent capacity.** In the NBBS architecture, the minimum amount of bandwidth needed by a connection to ensure that the packet loss ratio is below a specified threshold.

**Ethernet.** A 10-Mbps baseband local area network that allows multiple stations to access the transmission medium at will without prior coordination, avoids contention by using carrier sense and deference, and resolves contention by using collision detection and transmission. Ethernet uses carrier sense multiple access with collision detection (CSMA/CD).

## F

**fax.** Hardcopy received from a facsimile machine. Synonymous with *telecopy*.

**flash memory.** A data storage device that is programmable, erasable, and does not require continuous power. The chief benefit of flash memory over other programmable and erasable data storage devices is that it can be reprogrammed without being removed from the circuit board.

**frame relay (FR).** (1) An interface standard describing the boundary between user equipment and a fast-packet network. In frame relay systems, flawed frames are discarded, recovery is done end-to-end rather than hop-by-hop. (2) A technique derived from the D-channel standard of the integrated services digital network (ISDN).

**frequency.** The rate of signal oscillation, expressed in hertz.

**front-end processor (FEP).** A processor, such as the IBM 3745 or 3174, that relieves a main frame from the communication control tasks.

## G

**gateway.** (1) A functional unit that interconnects two computer networks with different network architectures. A gateway connects networks or systems of different architectures. A bridge interconnects networks or systems with the same or similar architectures. (T)  
(2) In the IBM Token-Ring Network, a device and its associated software that connect a local area network to another local area network or a host that uses different logical link protocols.

## H

**high-level data link control (HDLC).** An access service used over data networks. It uses a non-real-time connection.

The Nways Switch supports any HDLC-like data link control, for example:

- Synchronous data link control (SDLC) used with SNA, or
- Link access procedure for D-channel (LAP-D) used with ISDN.

**high-performance file system (HPFS).** In the OS/2 operating system, an installable file system that uses high-speed buffer storage, known as a cache, to provide fast access to large disk volumes. The file system also supports the coexistence of multiple, active file systems on a single personal computer, with the

## Glossary

capability of multiple and different storage devices. File names used with the HPFS can have as many as 254 characters.

**high-performance routing (HPR).** An addition to the Advanced Peer-to-Peer Networking (APPN) architecture that enhances data routing performance and reliability, especially when using high-speed links.

**hot pluggable.** Refers to a hardware component that can be installed or removed without disturbing the operation of any other resource that is not connected to, or dependant on, this component.

**hub (intelligent).** A wiring concentrator, such as the IBM 8260, that provides bridging and routing functions for LANs with different cables and protocols.

## I

**impedance.** The combined effect of resistance, inductance, and capacitance on a signal at a given frequency.

**Integrated Digital Network Exchange (IDNX).** A processor integrating voice, data, and image applications. It also manages the transmission resources, and connects to multiplexers and network management support systems. It allows integration of equipment from different vendors.

**integrated services digital network (ISDN).** A digital end-to-end telecommunication network that supports multiple services including, but not limited to, voice and data.

**Note:** ISDNs are used in public and private network architectures.

**interface.** (1) A shared boundary between two functional units, defined by functional characteristics, signal characteristics, or other characteristics, as appropriate. The concept includes the specification of the connection of two devices having different functions. (T) (2) Hardware, software, or both, that links systems, programs, or devices.

**Intermediate Session Routing (ISR).** A type of routing function within an APPN network node that provides session-level flow control and outage reporting for all sessions that pass through the node but whose end points are elsewhere.

**International Organization for Standardization (ISO).** An organization of national standards bodies from various countries established to promote development of standards to facilitate international exchange of goods and services, and develop cooperation in intellectual, scientific, technological, and economic activity.

**Internet.** (1) A worldwide network connecting users through autonomous networks in industry, education, government, and research. The Internet network uses Internet Protocol (IP). The major Internet services include electronic mail, FTP, telnet, World Wide Web, and electronic bulletin boards (Usenet). For network interconnection and routing, and Transmission Control Protocol (TCP) for end-to-end control. (A) (2) A collection of networks interconnected by a set of routers that allow them to function as a single, large network.

**Internetwork Packet Exchange (IPX).** The network protocol used to connect Novell's servers, or any workstation or router that implements IPX, with other workstations. Although similar to the Internet Protocol (IP), IPX uses different packet formats and terminology.

**Internet Protocol (IP).** A connectionless protocol that routes data through a network or interconnected networks. IP acts as an intermediary between the higher protocol layers and the physical network. However, this protocol does not provide error recovery and flow control and does not guarantee the reliability of the physical network.

## J

**jitter.** (1) Short-term non-cumulative variations of the significant instants of a digital signal from their ideal positions in time. (2) Undesirable variations of a transmitted digital signal. (3) Variations in the network delay.

## L

**line connection box (LCB).** A metallic box that provides:

- Multiplexing of up to 30 lines to one connector of a line interface coupler type 511 (LIC511)
- Reduced cable requirements between the Nways Switch and the DCE or DTE locations.

The LCBs fit in standard 19-inch racks. They house the active remote connectors (ARCs).

**line.** In an NBBS network, a communication link which can be a trunk line or a port line.

**line switching.** Synonym for *circuit switching*.

**link.** The combination of the link connection (the transmission medium) and two link stations, one at each end of the link connection. A link connection can be shared among multiple links in a multipoint or token-ring configuration.

**Link Address.** For the 2210 with an ESCON Channel Adapter, a port number determined as follows: If one

ESCD is in the communication path, it is the ESCON Director (ESCD) port number that is attached to the host. If two ESCDs are in the path, it is the host-side port number of the ESCD defined with the dynamic connection. When no ESCD is in the communication path, this value must be set to X'01.'

**link connection.** The physical equipment providing two-way communication between one link station and one or more other link stations; for example, a telecommunication line and data circuit-terminating equipment (DCE). Synonymous with *data circuit*.

**local.** Pertaining to a device accessed directly without use of a telecommunication line.

**local area network (LAN).** (1) A computer network located on a user's premises within a limited geographical area. Communication within a local area network is not subject to external regulations; however, communication across the LAN boundary may be subject to some form of regulation. (T) (2) A network in which a set of devices are connected to one another for communication and that can be connected to a larger network. See also *Ethernet* and *token ring*. (3) Contrast with *metropolitan area network (MAN)* and *wide area network (WAN)*. (4) A computer network located on a user's premises within a limited geographical area.

**logical partition.** A number assigned to a partition in a host that can operate in logically partitioned (LPAR) mode. In LPAR mode, the ESCON adapter can share a physical fiber connection with multiple host partitions.

**Logically Partitioned (LPAR) mode.** A function of some host processors in which processing is divided into logical partitions (LP) to provide the appearance of multiple processors. In LPAR mode, the ESCON adapter can share a physical fiber connection with multiple host partitions.

**LP.** logical partition

**LPAR.** logically partitioned

**LPAR mode.** Logically Partitioned (LPAR) Mode

**LPAR number.** Logical partition number. This allows multiple logical host partitions, LPARs, to share one ESCON fiber. This value is defined in the host Input/Output Configuration Program (IOCP) by the RESOURCE macro instruction. If the host is not using EMIF, use the default of 0 for the LPAR number.

## M

**management access.** An Nways Switch that connects a network management station, or a change control server, to an NBBS network.

**Management Information Base (MIB).** (1) A collection of objects that can be accessed by means of a network management protocol. (2) A definition for management information that specifies the information available from a host or gateway and the operations allowed. (3) In OSI, the conceptual repository of management information within an open system.

**metropolitan area network (MAN).** A network formed by the interconnection of two or more networks which may operate at higher speed than those networks, may cross administrative boundaries, and may use multiple access methods. (T) Contrast with *local area network (LAN)* and *wide area network (WAN)*.

**MIB.** (1) MIB module. (2) Management Information Base.

**modem (modulator/demodulator).** (1) A functional unit that modulates and demodulates signals. One of the functions of a modem is to enable digital data to be transmitted over analog transmission facilities. (T) (A) (2) A device that converts digital data from a computer to an analog signal that can be transmitted on a telecommunication line, and converts the analog signal received to data for the computer.

**module.** In the Nways Switch, a packaged functional hardware unit containing logic cards, connectors, and lights. The modules are used to package adapters, line interface couplers, voice server extensions, and other components. All modules are *hot pluggable* in the logic subracks.

**network.** (1) A configuration of data processing devices and software connected for information interchange. (2) A group of nodes and the links interconnecting them.

**network architecture.** The logical structure and operating principles of a computer network. (T)

**Note:** The operating principles of a network include those of services, functions, and protocols.

**network control.** The functions of the NBBS architecture that are performed by a control point of the Nways Switch to:

- Allocate and control the Nways Switch resources
- Provide the topology and directory services
- Select the routes
- Control congestion.

## Glossary

**network management.** The process of planning, organizing, and controlling a communication-oriented data processing or information system.

**network management station (NMS).** A station that runs NetView/AIX and the Nways Switch Manager. It manages the NBBS network topology, accounting, performance, configuration updates, and problem analysis.

A network management station is connected to its management access Nways Switch via an Ethernet LAN.

**Network Support Center (NSC).** A location from which IBM provides remote support to NBBS networks.

**Non-Return-to-Zero Changes-on-Ones Recording (NRZ-1).** A recording method in which the ones are represented by a change in the condition of magnetization, and zeros are represented by the absence of change. Only the one signals are explicitly recorded. (Previously called *non-return-to-zero inverted*, NRZI, recording.)

**Nways Switch.** Synonymous with IBM 2216 *Nways BroadBand Switch*.

**network support station (network support station).** The processor used to locally operate and service the Nways Switch. It is used by the Nways Switch administrator or service personnel.

**Nways Switch configuration station.** A dedicated OS/2 station running a stand-alone version of the Nways Switch Configuration Tool (NCT). It is used to generate a network configuration database and should be installed as a remote console.

## P

**packet loss ratio.** The probability that a packet will not reach its destination or not reach it within a specified time.

**packet mode operation.** Synonym for *packet switching*.

**packet switching.** (1) The process of routing and transferring data by means of addressed packets so that a channel is occupied only during transmission of a packet. On completion of the transmission, the channel is made available for transfer of other packets. (1) (2) Synonymous with *packet mode operation*. See also *circuit switching*.

**permanent virtual circuit (PVC).** In X.25 and frame relay communications, a virtual circuit that has a logical channel permanently assigned to it at each data terminal equipment (DTE). *gt.physical circuit gd. A*

circuit established without multiplexing. See also *data circuit*. Contrast with *virtual circuit*.

**Point-to-Point Protocol (PPP).** A protocol that provides a method for encapsulating and transmitting packets over serial point-to-point links.

**port.** (1) An access point for data entry or exit. (2) A connector on a device to which cables for other devices such as display stations and printers are attached. Synonymous with *socket*. (3) The representation of a physical connection to the link hardware. A port is sometimes referred to as an adapter; however, there can be more than one port on an adapter. There may be one or more ports controlled by a single DLC process. (4) In the Internet suite of protocols, a 16-bit number used to communicate between TCP or the User Datagram Protocol (UDP) and a higher-level protocol or application. Some protocols, such as File Transfer Protocol (FTP) and Simple Mail Transfer Protocol (SMTP), use the same well-known port number in all TCP/IP implementations. (5) An abstraction used by transport protocols to distinguish among multiple destinations within a host machine.

**port adapter.** A module, in models of the Nways Switch other than the 2216, running the code that provides the access services of the NBBS architecture to the port lines. In the 2216 the functions of the port adapter and the trunk adapter are combined in the Multiple Port/Trunk Adapter (MPTA).

**port line.** A communication line that connects an external user device to an Nways Switch and, thus, to the NBBS network. It can have different access services and interfaces: circuit emulation service (CES), pulse code modulation (PCM), high-level data link control (HDLC), or frame relay (FR).

In the Nways Switch, each port line is associated with one (or several) NBBS port(s).

**potential connection.** In the NBBS architecture, a predefined connection between two devices external to the NBBS network. It is defined by configuration parameters stored at one of the end-point Nways Switches.

**private branch exchange (PBX).** A private telephone exchange for transmission of calls to and from the public telephone network.

**problem determination.** The process of determining the source of a problem; for example, a program component, machine failure, telecommunication facilities, user or contractor-installed programs or equipment, environmental failure such as a power loss, or user error.

**pulse code modulation (PCM).** A standard adopted for the digitalization of an analog voice signal. In PCM,

the voice is sampled at a rate of eight kHz and each sample is coded in an 8-bit frame.

In an NBBS network, PCM is an alternative to circuit emulation services (CES) to carry voice and fax data.

## Q

**quality of service (QoS).** In the NBBS architecture, the quality of service guarantees the characteristics of a network connection. It concerns mainly end-to-end delay, jitter, and packet loss ratio.

## R

**rack.** A metallic structure, with a standard 19-inch width, that houses Nways Switch hardware elements: logic subrack with modules, fan boxes, and power subrack with power units.

**real-time processing.** The manipulation of data that are required, or generated, by some process while the process is in operation. Usually the results are used to influence the process, and perhaps related processes, while it is occurring.

**remote console.** A station running OS/2, TCP/IP, and the remote Nways Switch Resource Control program. It can be connected to any network support station (network support station) to operate and service the Nways Switch remotely.

The connection may be through:

- A switched line using a modem
- The NBBS network, if the remote console is connected to its access Nways Switch through an Ethernet LAN.

Any network support station can be used as a remote console of another network support station.

**resource.** In the Nways Switch, an hardware element or a logical entity created by the Control Program. For example, the adapters, LICs, and lines are physical resources. The control points, NBBS trunks, NBBS ports, and connections are logical resources.

In an NBBS network, the resources must be configured before being operated.

**resource profile.** A record of the characteristics of an Nways Switch resource. It includes, for example, the part number or module name, the change level, and the name and phone number of the person to contact in case of problem.

**ring.** See *ring network*.

**ring network.** (1) A network in which every node has exactly two branches connected to it and in which there

are exactly two paths between any two nodes. (T)  
(2) A network configuration in which devices are connected by unidirectional transmission links to form a closed path.

**route.** (1) An ordered sequence of nodes and transmission groups (TGs) that represent a path from an origin node to a destination node traversed by the traffic exchanged between them. (2) The path that network traffic uses to get from source to destination.

**router.** (1) A computer that determines the path of network traffic flow. The path selection is made from several paths based on information obtained from specific protocols, algorithms that attempt to identify the shortest or best path, and other criteria such as metrics or protocol-specific destination addresses. (2) An attaching device that connects two LAN segments, which use similar or different architectures, at the reference model network layer. Contrast with *bridge* and *gateway*. (3) In OSI terminology, a function that determines a path by which an entity can be reached.

**routing.** (1) The assignment of the path by which a message is to reach its destination. (2) In SNA, the forwarding of a message unit along a particular path through a network, as determined by parameters carried in the message unit, such as the destination network address in a transmission header.

## S

**SAP.** See Service Access Point

**Serial Line Internet Protocol (SLIP).** A protocol used over a point-to-point connection between two IP hosts over a serial line, for example, a serial cable or an RS232 connection into a modem, over a telephone line.

In an NBBS network, the SLIP is used over a connection between a network support station (network support station) and an IBM Network Support Center (NSC).

**Simple Network Management Protocol (SNMP).** In the Internet suite of protocols, a network management protocol that is used to monitor routers and attached networks. SNMP is an application layer protocol. Information on devices managed is defined and stored in the application's Management Information Base (MIB).

**Service Access Point.** A logical point made available by an adapter where information can be received and transmitted. A single SAP can have many links terminating in it.

**socket.** The abstraction provided by the University of California's Berkeley Software Distribution (commonly called Berkeley UNIX or BSD UNIX) that serves as an

## Glossary

endpoint for communication between processes or applications.

**source route bridging.** In LANs, a bridging method that uses the routing information field in the IEEE 802.5 medium access control (MAC) header of a frame to determine which rings or token-ring segments the frame must transit. The routing information field is inserted into the MAC header by the source node. The information in the routing information field is derived from explorer packets generated by the source host.

**spanning tree.** In the NBBS architecture, a logical tree touching every Nways Switch and providing a very fast and efficient way to multicast control information, such as the topology database updates.

**spoofing.** For data links, a technique in which a protocol initiated from an end station is acknowledged and processed by an intermediate node on behalf of the final destination. In IBM 6611 data link switching, for example, SNA frames are encapsulated into TCP/IP packets for transport across a non-SNA wide area network, unpacked by another IBM 6611, and passed to the final destination. A benefit of spoofing is the prevention of end-to-end session timeouts.

**subrack.** A metallic structure installed in a Nways Switch rack to hold modules or power supply elements.

**switch module (SW).** An Nways Switch module that interconnects the adapters through an ATM cell switch. It may have a backup.

**switch redrive (SWRD).** A module of the 2216 Model 501 that drives the signals from the switch module in the Model 500 to the adapters of the Model 501. It may have a backup.

**synchronous.** (1) Pertaining to two or more processes that depend upon the occurrence of specific events such as common timing signals. (T)  
(2) Occurring with a regular or predictable time relationship.

**Synchronous Data Link Control (SDLC).** A discipline conforming to subsets of the Advanced Data Communication Control Procedures (ADCCP) of the American National Standards Institute (ANSI) and High-level Data Link Control (HDLC) of the International Organization for Standardization, for managing synchronous, code-transparent, serial-by-bit information transfer over a link connection. Transmission exchanges may be duplex or half-duplex over switched or nonswitched links. The configuration of the link connection may be point-to-point, multipoint, or loop. (I) Contrast with *binary synchronous communication (BSC)*.

**synchronous optical network (SONET).** A US standard for transmitting digital information over optical

interfaces. It is closely related to the synchronous digital hierarchy (SDH) recommendation.

**system.** In data processing, a collection of people, machines, and methods organized to accomplish a set of specific functions. (I) (A)

**Systems Network Architecture (SNA).** The description of the logical structure, formats, protocols, and operational sequences for transmitting information units through, and controlling the configuration and operation of, networks. The layered structure of SNA allows the ultimate origins and destinations of information, that is, the end users, to be independent of and unaffected by the specific SNA network services and facilities used for information exchange.

## T

**TCP/IP.** (1) Transmission Control Protocol/Internet Protocol. (2) A UNIX-like/Ethernet-based system-interconnect protocol originally developed by the US Department of Defense. TCP/IP facilitated ARPANET (Advanced Research Projects Agency Network), a packet-switched research network for which layer 4 was TCP and layer 3, IP.

**TN3270.** An informally defined protocol for transmitting 3270 data streams over Telnet.

**time division multiplexing (TDM).** See *channelization*.

**token.** (1) In a local area network, the symbol of authority passed successively from one data station to another to indicate the station temporarily in control of the transmission medium. Each data station has an opportunity to acquire and use the token to control the medium. A token is a particular message or bit pattern that signifies permission to transmit. (T) (2) In LANs, a sequence of bits passed from one device to another along the transmission medium. When the token has data appended to it, it becomes a frame.

**token ring.** (1) According to IEEE 802.5, network technology that controls media access by passing a token (special packet or frame) between media-attached stations. (2) A FDDI or IEEE 802.5 network with a ring topology that passes tokens from one attaching ring station (node) to another. (3) See also *local area network (LAN)*.

**Transmission Control Protocol (TCP).** A communications protocol used in Internet and in any network that follows the U.S. Department of Defense standards for internetwork protocol. TCP provides a reliable host-to-host protocol between hosts in packet-switched communications networks and in interconnected systems of such networks. It assumes that the Internet protocol is the underlying protocol.



**Transmission Control Protocol/Internet Protocol (TCP/IP).** A set of communications protocols that support peer-to-peer connectivity functions for both local and wide area networks.

**transparent bridging.** In LANs, a method for tying individual local area networks together through the medium access control (MAC) level. A transparent bridge stores the tables that contain MAC addresses so that frames seen by the bridge can be forwarded to another LAN if the tables indicate to do so.

**transport services.** The functions of the NBBS architecture that are performed by an MPTA of the Nways Switch to:

- Support the attachment of trunk lines to the Nways Switch
- Maximize the bandwidth utilization
- Guarantee the qualities of service
- Transfer packets between Nways Switches
- Manage logical queues and schedule transmission.

**Trivial File Transfer Protocol (TFTP).** In the Internet suite of protocols, a protocol for file transfer that requires minimal overhead and minimal capability. TFTP uses the connectionless datagram delivery services of the User Datagram Protocol (UDP), which allows hosts that have no disk storage to implement TFTP in read-only memory (ROM) and use it to boot themselves.

**trunk.** See *NBBS trunk*.

**trunk adapter.** A module, in model so the Nways Switch other than the 2216, running the code that provides the transport services of the NBBS architecture to the trunk lines. In the 2216 the functions of the port adapter and the trunk adapter are combined in the Multiple Port/Trunk Adapter (MPTA).

**trunk line.** A high-speed line connecting two Nways Switches. It can be a coaxial cable, fiber cable, or radio wave, for example, and may be leased from telecommunication companies.

In the Nways Switch, each trunk line is associated with one NBBS trunk.

## V

**V.24.** In data communications, a specification of the CCITT that defines the list of definitions for interchange circuits between data terminal equipment (DTE) and data circuit-terminating equipment (DCE).

**V.25.** In data communications, a specification of the CCITT that defines the automatic answering equipment and parallel automatic calling equipment on the General Switched Telephone Network, including procedures for

disabling of echo controlled devices for both manually and automatically established calls.

**V.35.** In data communications, a specification of the CCITT that defines the list of definitions for interchange circuits between data terminal equipment (DTE) and data circuit-terminating equipment (DCE) at various data rates.

**V.36.** In data communications, a specification of the CCITT that defines the list of definitions for interchange circuits between data terminal equipment (DTE) and data circuit-terminating equipment (DCE) at rates of 48, 56, 64, or 72 kilobits per second.

**version.** A separately licensed program that usually has significant new code or new function.

**virtual circuit.** (1) In packet switching, the facilities provided by a network that give the appearance to the user of an actual connection. (T) See also *data circuit*. Contrast with *physical circuit*. (2) A logical connection established between two DTEs.

**virtual connection.** In frame relay, the return path of a potential connection.

**voice server adapter (VSA).** An Nways Switch module that provides additional voice functions such as silence removal, voice compression, and fax or modem detection. It allows the attachment of a voice server extension (VSE).

**voice server extension (VSE).** An Nways Switch module, attached to a voice server adapter (VSA), that provides the voice functions to an extended number of voice communication channels.

## W

**wide area network (WAN).** (1) A network that provides communication services to a geographic area larger than that served by a local area network or a metropolitan area network, and that may use or provide public communication facilities. (T) (2) A data communications network designed to serve an area of hundreds or thousands of miles; for example, public and private packet-switching networks, and national telephone networks. Contrast with *local area network (LAN)* and *metropolitan area network (MAN)*.

## X

**X.21.** An International Telegraph and Telephone Consultative Committee (CCITT) recommendation for a general-purpose interface between data terminal equipment and data circuit-terminating equipment for synchronous operations on a public data network.

## Glossary

**X.25.** An International Telegraph and Telephone Consultative Committee (CCITT) recommendation for the interface between data terminal equipment and packet-switched data networks. See also *packet switching*.

## Special Characters

**2216 Nways BroadBand Switch.** A fast packet switch enabling high-speed communications over an NBBS network. The 2216 Nways BroadBand Switch implements the functions defined by the Networking BroadBand Services architecture. Synonymous with *Nways Switch*.

## Index

### Numerics

- 2216
  - adapter plugging rules 2-2, B-1
  - backup
    - MPC+ 1-21
    - TCP/IP environment 1-19
    - VTAM environment 1-18
  - functional
    - summary 1-6
    - support for 1-4
  - host definition, required activities 1-26
  - LED indicators C-1
  - power
    - off 2-2
    - on 3-1
  - support 1-5
  - TCP/IP support 1-5
  - wiring harness 2-7

### A

- accessing
  - console process 5-1
  - ESCON interface
    - configuring 4-13
    - console 5-1
- adapter
  - cable position 2-7
  - connection 2-6
  - description 1-1
  - diagnostics 3-2
  - functions, description 1-1
  - inserting 2-4
  - installing 2-1
  - jumper cable 2-1
  - LED indicators C-1
  - planning 1-1
  - plugging rules 2-2, B-1
  - power
    - off 2-2
    - on 3-1
  - seating 2-5
  - slot selection 2-1
  - test 3-1
  - thumbscrews 2-5
  - unpacking 2-1
  - wrap plug 2-1, C-1
- add, ESCON configuration command 4-14
- AIB test A-5, A-6
- analysis of problems 1-40

- APARs 1-5
- APPN
  - LA loopback, configuring 4-25
  - LAN/WAN gateway 1-3
  - LSA
    - configuring the 2216 4-4
    - configuring the VTAM host 1-35
    - IBM 2216, configuring 4-7
- ATCSTRxx, VTAM initialization file 1-39
- ATM
  - Classical IP 1-5
  - LANE 1-5
- authentication scheme for SNMP 6-1

### B

- backup
  - configuration example 1-16
  - MPC+, example 1-21
  - TCP/IP environment, example 1-19
  - VTAM environment, example 1-18

### C

- cable
  - adapter, position 2-7
  - connecting 2-6
  - duplex-to-biconic test A-7
  - jumper 2-1
  - requirements 2-1
- channel
  - characteristics, host channel support 1-8
  - network connections 1-5
  - supported 1-6
- co-requisites 1-5
- command line interface 3-1
- communications
  - protocols supported by 2216 1-6
  - supported through LAN/WAN gateway 1-2
- community considerations, SNMP 6-1
- configuration
  - accessing commands 4-13
  - APPN
    - loopback 4-25
  - backup, example 1-16
  - considerations 1-23
  - diagnostics for configuration file A-1
  - ESCON interface
    - add, command 4-14
    - delete, command 4-26
    - exit, command 4-29
    - list, command 4-28
    - mod, command 4-27

## Glossary

### configuration (*continued*)

#### ESCON interface (*continued*)

- required actions 4-13
- summary of commands 4-14

#### file, diagnostics A-1

#### host

- planning for definition 1-26
- required for defining connection 1-26

#### LCS

- subchannel 4-16
- virtual interface 4-15

#### LSA

- APPN connection 4-7
- direct connection 4-6
- direct connection at VTAM host 1-35
- DLSw connection at 2216 4-9
- DLSw local conversion at 2216 4-10
- subchannel 4-19
- virtual interface 4-17

#### MPC+ 4-11

- subchannel 4-22
- virtual interface 4-21

#### MVS host for TCP/IP 1-31

#### network command, ESCON interface 4-13

#### network, planning 1-23

#### overview 4-1

#### prior to, planning activities 1-22

#### reconfiguration 1-40

#### VTAM host

- APPN connection 1-35
- DLSw connection 1-36
- MPC+ 1-39

#### connecting adapter cable 2-6

#### connections, channel and network 1-5

#### console process, accessing 5-1

#### coupler, duplex-to-duplex A-7

## D

#### dedicated subchannels 1-2

#### default, factory plugging B-1

#### defining 2216

##### channel attachment, planning 1-22

##### LAN attachment, planning 1-22

##### to operating system 1-30

#### delete, ESCON configuration command 4-26

#### Device Status Page panel 3-2, A-2

#### devices, testable A-2

#### Diagnostic Menu panel A-2

#### diagnostics

##### adapter 3-2

##### configuration file A-1

##### Device Status Page panel A-2

##### Diagnostic Menu panel 3-2, A-2

##### Diagnostic Status field A-3

##### Fault Status field A-3

### diagnostics (*continued*)

#### hardware A-1

#### interactive test options A-6

#### online A-1

#### operational code A-1

#### optical power measurement test A-7

#### setup for optical test A-8

#### Test Control Menu panel A-3, A-4

#### Test Options panel A-6, A-7

#### testing A-1

#### direct connection, LSA, configuring 4-6

#### displaying monitoring prompt 5-1

#### DLSw connection

##### configuring

###### 2216 4-9

###### local conversion at the 2216 4-10

###### VTAM host 1-36, 1-37

##### LSA 4-9, 4-10

#### duplex-to-biconic test cable A-7

#### duplex-to-duplex coupler A-7

## E

### EMIF

#### attachment, ES/9000, example 1-10

#### example IOCP definition 1-28

#### Enterprise Systems Connection 2-1

#### ESA system required 1-5

#### ESCON Channel Adapter 2-4

##### accessing the console process 5-1

##### configuration 4-1

##### configuration commands

###### add 4-14

###### delete 4-26

###### exit 4-29

###### list 4-28

###### mod 4-27

###### summary 4-14

##### configuring interface 4-13

##### diagnostic testing A-1

##### inserting 2-4

##### installation restrictions 2-2

##### interface console commands

###### exit 5-5

###### list 5-2

###### net 5-4

###### summary 5-2

#### LAN Channel Station (LCS)

##### configuring the 2216 4-4

##### configuring the MVS host for TCP/IP 1-31

##### overview 4-4

#### LCS interface console commands

##### exit 5-6

##### list 5-5

##### summary 5-5

#### Link Services Architecture (LSA)

##### APPN connection 4-7

ESCON Channel Adapter (*continued*)

- Link Services Architecture (LSA) (*continued*)
  - direct connection 4-6
  - DLSw local conversion 4-10
  - host control blocks 1-34
  - overview 4-5
- LSA interface console commands
  - exit 5-9
  - list 5-7
  - summary 5-7
- messages D-1
- MIB support 6-2
- monitoring 5-1
- MPC+ Interface console commands
  - exit 5-14
  - list 5-10
  - summary 5-10
- Multi-Path Channel+ (MPC+)
  - configuring the 2216 4-11
  - configuring the VTAM host 1-39
  - Local SNA Major Node control block 1-39
  - overview 4-11
  - Transport Resource List (TRL) control block 1-39
- overview 4-1
- restrictions for installing 2-2
- SNMP Support 6-2
- testing, diagnostic A-1

ESCON functional support

- ATM Classical IP 1-5
- ATM LANE 1-5
- Ethernet 1-5
- Ethernet V2 1-5
- Ethernet/802.3 1-5
- Serial FR, bridged 1-5
- Serial PPP 1-5
- Token Ring 1-5

Ethernet 1-5

Ethernet V2 1-5

Ethernet/802.3 1-5

examples

- 2216 definition to TCP/IP for MVS or VM 1-32
- backup configuration 1-16
- direct attachment, S/390 and 2216 1-8
- EMIF attachment, ES/9000 processor and 2216 1-10
- host failure, recovery 1-16
- IOCP
  - definition for EMIF host 1-28
  - definition for ESCON channel 1-26
- LCS and LSA subchannels 1-14
- MPC+
  - backup 1-21
  - subchannels 1-15
- multiple systems attachment with ESCDs 1-10
- single attachment, S/390 and 2216s 1-9

examples (*continued*)

- switched major node definition file
  - LSA APPN connection at VTAM host 1-36
  - LSA direct connection at VTAM host 1-35
  - LSA DLSw connection at VTAM host 1-36
  - LSA DLSw local conversion at VTAM host 1-37
  - VTAM control block 1-34
- TCP/IP environment, backup 1-19
- VTAM environment, backup 1-18
- XCA major node definition file
  - LSA APPN connection at VTAM host 1-35
  - LSA direct connection at VTAM host 1-35
  - LSA DLSw connection at VTAM host 1-36
  - LSA DLSw local conversion at VTAM host 1-37
  - VTAM control block 1-34

exit

- ESCON configuration command 4-29
- ESCON interface console command 5-5
- LCS interface console command 5-6
- LSA interface console command 5-9
- MPC+ interface console command 5-14

## F

- factory plugging defaults B-1
- Fault Status field A-3
- fiber optic link planning 2-1
- frame size 1-24
- function
  - description 1-1
  - support for 2216 1-4
- functional summary, 2216 1-6
- functional support, ESCON
  - ATM Classical IP 1-5
  - ATM LANE 1-5
  - Ethernet 1-5
  - Ethernet V2 1-5
  - Ethernet/802.3 1-5
  - Serial FR, bridged 1-5
  - Serial PPP 1-5
  - Token Ring 1-5

## H

- hardware configuration definition program 1-26
- hardware, diagnostics A-1
- HCD
  - MVS/ESA definition 1-30
  - program 1-26
- host
  - 2216 connection, required activities 1-26
  - channel support, characteristics 1-8
  - control blocks 1-34
  - failure, recovery 1-16
  - input/output configuration program 1-26
  - number of programs supported 1-12

## Glossary

host (*continued*)

planning 1-6

programs

dedicated subchannels 1-2

interconnect enhancement feature 1-5

LAN/WAN gateway 1-2

TCP/IP 1-5

VTAM, configuring 1-39

HPDT services, MPC+ 1-3

## I

I/O Configuration Data Set 1-26

indicators, LED C-1

initialization file ATCSTRxx, for VTAM 1-39

insert ESCON adapter 2-4

installation restrictions 2-2

installing adapter 2-1

interactive test options A-6

interconnect enhancement feature, required by VTAM 1-5

interface console commands

ESCON 5-2

LCS 5-5

LSA 5-7

MPC+ 5-10

interface numbers, displaying 5-1

IOCDS 1-26

IOCP

definitions 1-26

example definition for ESCON channel 1-26

## J

jumper cable 2-1

## L

LAN Channel Station (LCS)

configuring

2216 4-4

MVS host for TCP/IP 1-31

host failure, recovery 1-16

LCS interface console commands

exit 5-6

list 5-5

summary 5-5

messages D-12

overview 4-4

subchannel, configuring 4-16

subchannels, example 1-14

virtual interface, configuring 4-15

LAN/WAN gateway

description 1-2

number of connections 1-8

rules for definitions, LCS and LSA

subchannels 1-14

LCS

See LAN Channel Station (LCS)

LED indicators C-1

light reception test 3-6, A-6

lights C-1

Link Services Architecture (LSA)

APPN connection

configuring the 2216 4-7

configuring the VTAM host 1-35

direct connection

at VTAM host, configuring 1-35

configuring the 2216 4-6

DLSw connection

configuring the 2216 4-9, 4-10

configuring the VTAM host 1-36, 1-37

host

control blocks 1-34

failure, recovery 1-16

LSA interface console commands

exit 5-9

list 5-7

summary 5-7

messages D-16

overview 4-5

subchannel, configuring 4-19

subchannels, example 1-14

virtual interface, configuring 4-17

VTAM, sharing interface 1-12

list

ESCON

configuration command 4-28

interface configuration command 4-14

interface console command 5-2

LCS interface console command 5-5

LSA interface console command 5-7

MPC interface console command 5-10

MPC+ interface console command 5-14

list devices, command 4-13

LLC messages D-34

Local SNA Major Node control block 1-39

logical link control messages D-34

loop test - stop on first error A-5

loopback, APPN, configuring 4-25

LSA

See Link Services Architecture (LSA)

## M

memory test A-5

messages

ESCON network interface D-1

LCS interface D-12

list of D-1

LLC D-34

LSA interface D-16

MPC+ interface D-28

messages (*continued*)  
 TTY console 3-1

MIB support  
 description 6-1  
 ESCON supported 6-2  
 World Wide Web URL 6-1

mod, ESCON configuration command 4-27

monitoring  
 ESCON Channel Adapter 5-1  
 prompt, displaying 5-1

MPC+  
 See Multi-Path Channel+ (MPC+)

Multi-Path Channel+ (MPC+)  
 configuring the 2216 4-11  
 configuring the VTAM host 1-39  
 HPDT services 1-3  
 list, interface console command 5-10  
 messages D-28  
 overview 4-11  
 rules for definitions, subchannels 1-15  
 subchannel, configuring 4-22  
 summary, interface console commands 5-10  
 support, description 1-3  
 virtual interface, configuring 4-21

Multi-Path Channel+ (MPC+)  
 recovery example 1-21

multiple systems attachment with ESCDs,  
 example 1-10

MVS host, configuring for TCP/IP 1-31

MVS/ESA  
 2216 support 1-5  
 APAR for VTAM V3 and ESCON 1-5  
 defining the 2216 to 1-30  
 hardware configuration definition 1-30  
 HCD 1-30

MVS/XA, defining the 2216 to 1-30

**N**

net, ESCON interface console command 5-4

network  
 channel connections 1-5  
 command 4-13  
 Community 6-1  
 including 2216 in, considerations 1-23  
 management 6-1  
 messages, ESCON network interface D-1  
 supported by 2216 1-6

number  
 host programs supported 1-12  
 hosts, host programs and users, supported 1-11  
 sessions, considerations 1-12

**O**

online diagnostics A-1

OPCON  
 accessing the ESCON interface 4-13  
 command line interface 3-1  
 description 3-1  
 ESCON interface, console 5-1

operating system  
 defining the 2216 to 1-30  
 MVS 1-5  
 required ESA system 1-5  
 supported by 2216 1-5  
 VM 1-5  
 VSE/ESA 1-5

operator control module (OPCON) 3-1

optical power  
 meter A-7  
 Setup for Optical Test panel A-8  
 test A-6, A-7

Optical Test in Progress panel A-9

optimizing performance 1-24

overview of ESCON Channel Adapter 4-1

**P**

panels  
 Device Status Page 3-2, A-2  
 Diagnostic Menu 3-2, A-2  
 Optical Test in Progress A-9  
 Restore from Light Reception Test 3-7  
 Restore from Light Reception Test panel 3-7  
 Restore From Wrap Test 3-5  
 Setup for Light Reception Test 3-6  
 Setup for Optical Test A-8  
 Setup for Wrap Test 3-4  
 Test Control Menu 3-3, 3-4, 3-7, A-3, A-4  
 Test Control Menu panel A-3  
 Test Options 3-3, 3-6, A-7  
 Test Results 3-5, 3-8

PCI bus test A-5

performance, optimizing 1-24

planning and preparation  
 2216 ESCON adapter 1-1, 1-6, 1-22, 1-39  
 defining 2216  
 channel attachment 1-22  
 LAN attachment 1-22  
 frame size 1-24  
 host 1-1, 1-26, 1-39  
 network, including 2216 in 1-23  
 prior to, activities 1-22  
 sharing subchannels 1-24  
 TCP/IP window size 1-24  
 trace function 1-24  
 VTAM buffer size 1-24

## Glossary

- plugging rules 2-2, B-1
- position adapter cable 2-7
- power meter, optical A-7
- power off 2216 2-2
- power on
  - 2216 3-1
  - adapter 3-1
- power test, optical A-6
- prerequisites 1-5
- problem analysis and resolution 1-40
- processor test A-5
- programs, host, interconnect enhancement feature
- prompt, monitoring, displaying 5-1
- protocol
  - communications, supported by 2216 1-6
  - TCP/IP 1-5

## R

- reconfiguration 1-40
- recovering from host failures 1-16
- reference publications list xiv
- requirements
  - cable 2-1
  - system, determining 1-8
- Restore From Wrap Test panel 3-5
- restrictions, installation of ESCON Channel Adapter 2-2

## S

- S/390 host
  - direct attachment example 1-8
  - single attachment example 1-9
- seating the ESCON adapter 2-5
- selecting adapter slot 2-1
- Serial FR, bridged 1-5
- Serial PPP 1-5
- sessions, number of, considerations 1-12
- Setup for Light Reception Test panel 3-6
- Setup for Optical Test panel A-8
- Setup for Wrap Test panel 3-4
- sharing subchannels 1-24
- slot, adapter, selecting 2-1
- SNMP
  - authentication scheme 6-1
  - MIB support 6-1
  - Overview 6-1
  - SNMP support 6-2
- start-up parameter for VTAM, ATCSTRxx 1-39
- subchannels
  - dedicated 1-2
  - examples
    - LCS and LSA 1-14
    - MPC+ 1-15
    - LCS, configuring 4-16

- subchannels (*continued*)
  - LSA, configuring 4-19
  - MPC+, configuring 4-22
  - number provided 4-1
  - rules 1-13
  - sharing 1-24
- support, World Wide Web URL for IBM 2216 MIB 6-1
- switched major node definition file, examples
  - LSA APPN connection at VTAM host 1-36
  - LSA direct connection at VTAM host 1-35
  - LSA DLSw connection at VTAM host 1-36
  - LSA DLSw local conversion at VTAM host 1-37
  - VTAM control block 1-34
- system
  - functional support for 1-5
  - operating 1-5
  - requirements, determining 1-8

## T

- TCP/IP
  - 2216 definition for MVS or VM, example 1-32
  - 2216 support 1-5
  - configuring LAN Channel Station (LCS) 1-31
  - configuring MVS host 1-31
  - LAN/WAN gateway 1-3
  - protocol 1-5
  - recovery example 1-19
  - window size, optimizing performance 1-24
- test
  - adapter 3-1
  - AIB A-5, A-6
  - cable, duplex-to-biconic A-7
  - interactive options A-6
  - light reception A-6
  - memory A-5
  - optical power A-6, A-7
  - PCI bus A-5
  - processor A-5
  - Restore from Light Reception Test panel 3-7
  - Restore From Wrap Test panel 3-5
  - Test Control Menu panel 3-3, 3-4, 3-7, A-3, A-4
  - Test Options panel 3-3, 3-6, A-6, A-7
  - Test Results panel 3-5, 3-8
  - timer A-5
  - wrap plug A-6
  - Test Control Menu panel 3-3, 3-4, 3-7
  - Test Options panel 3-3, 3-6
  - Test Results panel 3-5, 3-8
- testable devices A-2
- testing, diagnostic A-1
- thumbscrews 2-5
- timer test A-5
- Token Ring 1-5
- trace function 1-24



Transport Resource List (TRL) control block 1-39  
 trap messages, SNMP 6-2  
   trap messages 6-2  
 TTY console messages 3-1

XCA major node definition file, examples (*continued*)  
 VTAM control block 1-34

## U

unpacking adapter 2-1  
 users, number of, considerations 1-12

## V

virtual  
   interface  
     LCS, configuring 4-15  
     LSS, configuring 4-17  
     MPC+, configuring 4-21  
   network handlers 4-1  
 VM, 2216 support 1-5  
 VM/ESA  
   APAR for VTAM V3 and ESCON 1-5  
 VM/ESA, defining the 2216 to 1-30  
 VM/SP, defining the 2216 to 1-30  
 VM/XA, defining the 2216 to 1-30  
 VSE/ESA, 2216 definition 1-31  
 VTAM  
   2216 support 1-5  
   buffer size, optimizing performance 1-24  
   configuring the host  
     APPN connection, LSA 1-35  
     DLSw connection 1-36  
     MPC+ 1-39  
   environment, 2216 backup 1-18  
   HPDT services 1-3  
   initialization file ATCSTRxx 1-39  
   Interconnect Enhancement Feature 1-5  
   LSA direct connection, configuring 1-35  
   MPC+ 1-3  
   recovery example 1-18  
   sharing LSA interface 1-12  
   start-up parameter 1-39  
   Version 4.1 1-5

## W

wiring harness 2-7  
 World Wide Web URL for IBM 2216 MIB support 6-1  
 wrap plug 2-1, C-1  
 wrap plug test A-6

## X

XCA major node definition file, examples  
   LSA APPN connection at VTAM host 1-35  
   LSA direct connection at VTAM host 1-35  
   LSA DLSw connection at VTAM host 1-36  
   LSA DLSw local conversion at VTAM host 1-37



---

# Tell Us What You Think!

**2216 Nways Multiaccess Connector  
ESCON Channel Adapter  
Planning and Setup Guide  
Publication No. GA27-4193-00**

We hope you find this publication useful, readable, and technically accurate, but only you can tell us! Your comments and suggestions will help us improve our technical publications. Please take a few minutes to let us know what you think by completing this form. If you are in the U.S.A., you can mail this form postage free or fax it to us at 1-800-253-3520. Elsewhere, your local IBM branch office or representative will forward your comments or you may mail them directly to us.

|                                                                          |                          |                          |
|--------------------------------------------------------------------------|--------------------------|--------------------------|
| <b>Overall, how satisfied are you with the information in this book?</b> | Satisfied                | Dissatisfied             |
|                                                                          | <input type="checkbox"/> | <input type="checkbox"/> |

|                                                                    |                          |                          |
|--------------------------------------------------------------------|--------------------------|--------------------------|
| <b>How satisfied are you that the information in this book is:</b> | Satisfied                | Dissatisfied             |
| Accurate                                                           | <input type="checkbox"/> | <input type="checkbox"/> |
| Complete                                                           | <input type="checkbox"/> | <input type="checkbox"/> |
| Easy to find                                                       | <input type="checkbox"/> | <input type="checkbox"/> |
| Easy to understand                                                 | <input type="checkbox"/> | <input type="checkbox"/> |
| Well organized                                                     | <input type="checkbox"/> | <input type="checkbox"/> |
| Applicable to your task                                            | <input type="checkbox"/> | <input type="checkbox"/> |

Specific comments or problems:

---

---

---

Please tell us how we can improve this book:

---

---

---

Thank you for your comments. If you would like a reply, provide the necessary information below.

\_\_\_\_\_  
Name

\_\_\_\_\_  
Address

\_\_\_\_\_  
Company or Organization

\_\_\_\_\_

\_\_\_\_\_  
Phone No.

\_\_\_\_\_



Fold and Tape

Please do not staple

Fold and Tape



NO POSTAGE  
NECESSARY  
IF MAILED IN THE  
UNITED STATES

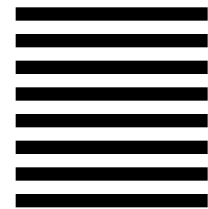

# BUSINESS REPLY MAIL

FIRST-CLASS MAIL PERMIT NO. 40 ARMONK, NEW YORK

POSTAGE WILL BE PAID BY ADDRESSEE

Design & Information Development  
Dept. CGF/Bldg. 656  
International Business Machines Corporation  
PO BOX 12195  
RESEARCH TRIANGLE PARK NC 27709-9990



Fold and Tape

Please do not staple

Fold and Tape





Part Number: 85H9709

GA27-4193-00



85H9709

